

SALEEN SERIES VI.5 SUPERCHARGER KIT

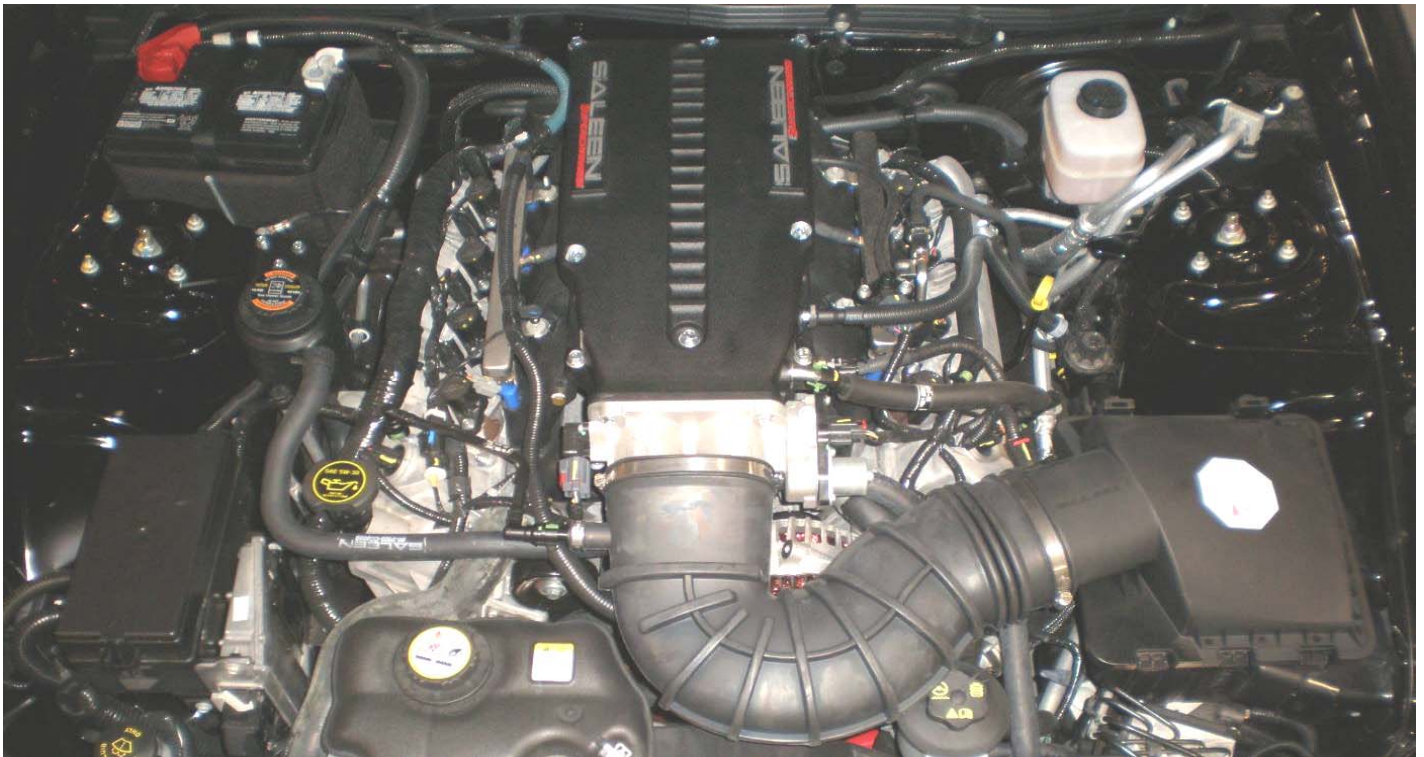

INSTALLATION MANUAL: Saleen S-Series / H-Series / Mustang GT

(S281 3V, H281 3V, & Mustang GT)

2005 - 2009 Model Year

P/N: 10-8002-C11517M



Saleen Performance Vehicles

1-800-888-8945

www.saleen.com

* Please keep this manual with the vehicle.

This manual contains maintenance, service, and parts information important to the operation of the motor and supercharger.



IF YOU ARE NOT EXPERIENCED IN THE AREA OF AUTOMOTIVE MECHANICS, WE STRONGLY URGE THAT YOU REFER THIS INSTALLATION TO A CERTIFIED INSTALLER OR TECHNICIAN.

ENSURE THE VEHICLE PARKING BRAKE IS ON AND THE TRANSMISSION IS IN PARK OR IN GEAR WHEN WORKING ON IT.

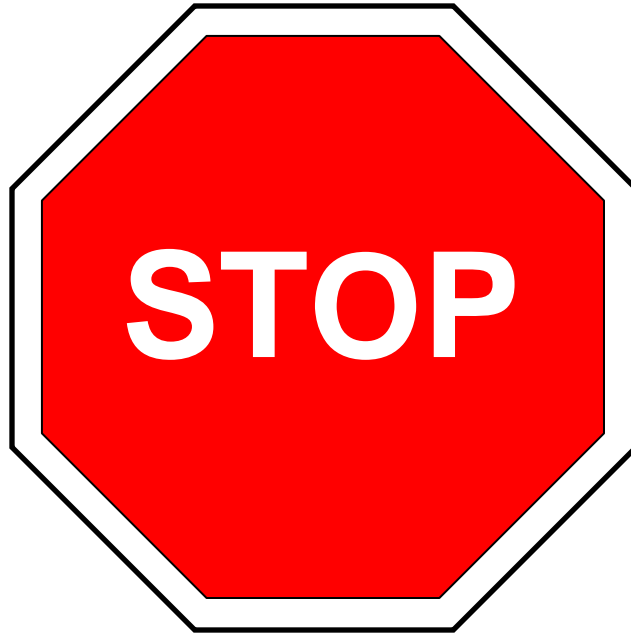

DO NOT INSTALL ANY AFTERMARKET CHIPS OR PROGRAMMERS, OR HAVE YOUR PCM REPROGRAMMED ANYWHERE BUT AT SALEEN FOR THIS SUPERCHARGER KIT. THE 2005 to 2009 MUSTANG USES AN ELECTRONIC THROTTLE CONTROL (ETC), WHICH IS CONTROLLED BY THE POWERTRAIN CONTROL MODULE (PCM) AND THE CALIBRATION INSIDE. AFTERMARKET CHIPS DO NOT PROPERLY RECALIBRATE THE ENGINE MANAGEMENT SYSTEM; THIS CREATES A DANGEROUS SITUATION THAT COULD RESULT IN A STUCK THROTTLE AND CAN LEAD TO INJURY OR DEATH. SALEEN FULLY REPROGRAMS THE PCM TO FORD STANDARDS, AND ENSURES THAT ALL ENGINE SAFETY CONTROLS ARE FULLY FUNCTIONAL.

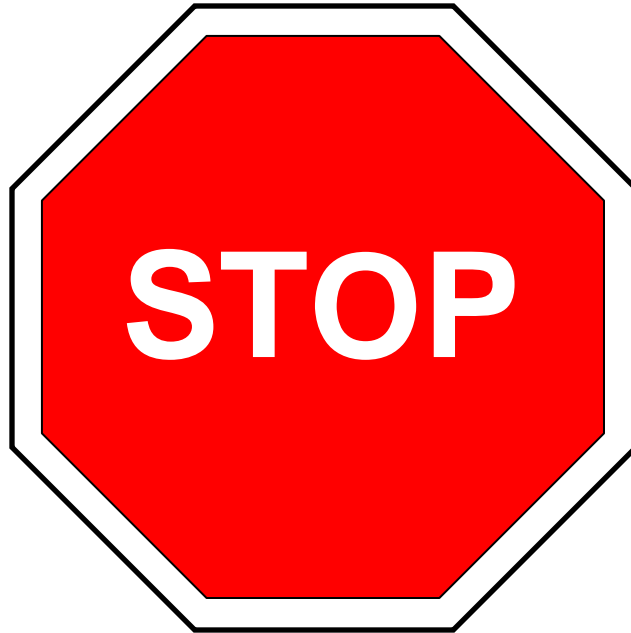

THE SALEEN SERIES VI.5 SUPERCHARGER AND ACCOMPANYING PROGRAMMING ARE DESIGNED AROUND THE USE OF 91 OCTANE FUEL OR HIGHER ONLY. BEFORE YOU RUN YOUR MUSTANG WITH THE SERIES VI KIT INSTALLED EVEN ONCE, YOU MUST EITHER DRAIN THE FUEL TANK COMPLETELY AND FILL IT UP WITH 91 OCTANE, OR BEGIN USING 91 OCTANE IN YOUR MUSTANG TWO COMPLETE FILLUPS BEFORE INSTALLATION.



Table of Contents

- A** (2005 to 2006 Model) **C** (2009 Model)
- B** (2007 to 2008 Model)
- D** (Saleen Naturally Aspirated Pulley Kit - S281 3V & H281 3V)
- E** (Stock Mustang GT Model) **G** (H - Series Model)
- F** (S - Series Model)

I. Table of Contents	Pg. I to II
II. Precautions (PLEASE READ CAREFULLY)	Pg. III
III. Introduction	Pg. IV
IV. Requirements	
1. Parts List	Pg. V to VIII
2. Tool List	Pg. IX
V. Tear-Down Instructions	
Battery & Tray Removal	Pg. 1
PCM Removal	Pg. 2
PCM Questionnaire	Pg. 3
Hood Removal	Pg. 4
E Front Fascia Removal (Stock)	Pg. 5E to 7E
F Front Fascia Removal (Saleen S-Series)	Pg. 5F to 7F
G Front Fascia Removal (Saleen H-Series)	Pg. 5G to 7G
Front Bump Isolator Removal	Pg. 8
Air Intake Tube & Air Box Removal	Pg. 9
Stock Serpentine Belt Removal	Pg. 10
Engine Coolant Removal	Pg. 11
Throttle Body Removal	Pg. 12
Fuel Rail Removal	Pg. 13 to 14
Intake Manifold Removal	Pg. 15 to 16
Alternator Removal	Pg. 17 to 18
A Upper Radiator Hoses Disconnection (2005 to 2006 Model)	Pg. 19A
B & C Upper Radiator Hose Removal (2007 to 2009 Model)	Pg. 19BC
Water Crossover Removal	Pg. 20
Water Tube Assembly Removal	Pg. 21
D Pulleys Replacement Process (Saleen N/A Pulley Kit Only)	Pg. 22D
Pulleys & Fasteners Removal	Pg. 23
A Coolant Hose Assembly Removal (2005 to 2006 Model)	Pg. 24A
RH (Passenger) Front Wheel Removal	Pg. 25
RH (Passenger) Front Fender Well Removal	Pg. 26
VI. Parts Assembly & Modification Instructions	
Fuel Rail & Injectors Installation	Pg. 27 to 28
Water Crossover Assembly	Pg. 29
A & B Alternator Pulley Replacement (2005 to 2008 Model)	Pg. 30AB to 31AB
C Alternator Pulley Replacement (2009 Model)	Pg. 30C to 31C
A & B Alternator Harness Modification (2005 to 2008 Model)	Pg. 32AB to 35AB
C Alternator Harness Modification (2009 Model)	Pg. 32C to 36C
Air Box Modification & Lid Assembly	Pg. 37 to 38



Table of Contents

- A** (2005 to 2006 Model) **C** (2009 Model)
- B** (2007 to 2008 Model)
- D** (Saleen Naturally Aspirated Pulley Kit - S281 3V & H281 3V)
- E** (Stock Mustang GT Model) **G** (H - Series Model)
- F** (S - Series Model)

VI. Installation Instructions

Water Pump Harness Installation: Routing	Pg. 39 to 40
RH (Passenger) Front Fender Well Installation	Pg. 41
RH (Passenger) Front Wheel Installation	Pg. 42
Water Pump Harness Installation: Wiring	Pg. 43 to 45
Idler Pulley Installation	Pg. 46
A Radiator Plumb. Conversion Kit (2005 to 2006 Model)	Pg. 47A
B & C I/C Recovery Tank Bracket Installation (2007 to 2009 Model)	Pg. 48BC
Lower Heater Core Hose Replacement	Pg. 49
B & C Heat Exchanger Installation (2007 to 2009 Model)	Pg. 50BC
A Heat Exchanger Installation (2005 to 2006 Model)	Pg. 50A
Intercooler Water Pump Installation	Pg. 51 to 53
Alternator Idler Pulley & Bracket Installation	Pg. 54 to 55
Water Tube Assembly Installation	Pg. 56
Engine Compartment Bulkhead Modification	Pg. 57
Engine Head Port Inspection	Pg. 58
Supercharger Assembly Installation	Pg. 59 to 60
Water Crossover Installation	Pg. 61 to 62
Alternator Installation	Pg. 63
Alternator Harness Installation	Pg. 64
Serpentine Belt Installation: Routing	Pg. 65
Vacuum Hoses Modification	Pg. 66 to 67
ACT Harness Installation	Pg. 68
Intercooler Water Pump to Recovery Tank Hose Installation	Pg. 69
Recovery Tank Installation	Pg. 70
Heat Exchanger Hose Installation	Pg. 71
Intercooler to Recovery Tank Hose Installation	Pg. 72
Throttle Body Installation	Pg. 73
Supercharger Assembly to Engine Connections	Pg. 74
Air Box & Intake Snorkel Installation	Pg. 75
E Front Fascia Installation (Stock)	Pg. 76E to 78E
F Front Fascia Installation (Saleen S-Series)	Pg. 76F to 78F
G Front Fascia Installation (Saleen H-Series)	Pg. 76G to 78G
Hood Installation	Pg. 79
Saleen Programmed PCM Installation	Pg. 80
Battery & Tray Installation	Pg. 81
Intercooler Coolant Fill	Pg. 82
Engine Coolant Fill	Pg. 83
Vehicle Decal Installation	Pg. 84

VII. Post-Installation

Post Installation Information	Pg. 85
-------------------------------	--------



Pre-Installation Precautions:

To help ensure the proper operation of your vehicle, follow the guidelines below:



IF YOU ARE NOT EXPERIENCED in the area of automotive mechanics, we strongly urge that you refer this installation to a certified installer or technician.

PAY ATTENTION TO VEHICLE TYPE NOTATION because there are installation steps in this manual that differ based on whether your vehicle is a Saleen S-Series product, Saleen H-Series product, or a factory Mustang GT*. Installation procedures also vary depending on the model year. There will be clear markings at the lower RH corner of the page (**A - G designations**). Taking the time to read these instructions along with following the notes will ensure a smooth, easy, and successful installation**.

*This instruction manual consists of the three most likely vehicle types for this kit (Saleen S-Line, Saleen H-Line, & Factory Stock Mustang). Saleen cannot anticipate what modifications may be done to every vehicle, so there may be an installation conflict with some aftermarket equipment.

**This manual was created during the production process, using the Saleen S281SC as an example. Any form of aftermarket body kits may require different or additional steps when removing body components (such as the front fascia or hood) may be different than the instructions listed in this manual. If the vehicle does contain other aftermarket body components, contact that aftermarket supplier for disassembly and assembly instructions.

Safety Precautions:

To help guarantee your safety, please follow the guidelines listed below:



NO SMOKING, FLAMES, OR SPARKS around the battery or fuel system. Batteries can give off fumes that are flammable and may ignite if there is any form of spark or open flame near it.



WEAR THE APPROPRIATE SAFETY GEAR such as safety glasses and gloves during the vehicle tear down and installation of new components. Always follow the safety instructions that come with the tools you are using.



USE CAUTION AROUND VEHICLE when working on it. Make sure the vehicle is turned **OFF**, is properly secured (in park or in gear with the parking brake on), and is sitting on a level surface.

If a hoist or floor jack is required, make sure the vehicle is in park or in gear and the parking brake on. If using a floor jack, make sure the vehicle is on a level surface, the rear tires are chocked, and the vehicle is being supported by jack stands. Follow ALL safety guidelines & operational instructions spelled out in the hoist or floor jack's owners manual. Failure to do so may result in serious injury.

Avoid wearing loose clothing or jewelry, as these items might get caught in moving parts resulting in injury. When instructed to operate your vehicle, make sure you do so in a well-ventilated area (to prevent carbon monoxide poisoning).

Be safe and use proper care and precautions. Saleen wants you to have a safe and rewarding experience.



Installation Guide 475 H.P. Series VI.5 Supercharger Kit 2005 to 2009

WELCOME!

Thank you for buying the newly improved Saleen 475HP Series VI.5 Supercharger Kit for your 2005 to 2009 Mustang (4.6 Liter, 3-Valve engine).

The new kit contains an improved water crossover design now with an integrated thermostat. The kit also includes a more efficient supercharger housing for improved flow characteristics. We appreciate your business, and we hope you enjoy your product.

For your benefit, please read the following instructions completely and thoroughly before attempting to install the supercharger kit. Many questions we have received from customers about the installation of our products could have been easily solved by information listed in this installation guide. We want you to enjoy this product in its fully functional state, and reading this tutorial is a great first step to getting you on your way to a more unique and powerful Mustang.

Please review the VERY IMPORTANT instructions below before proceeding with the kit installation.

- Please note that if you have ANY aftermarket parts already installed on your Mustang, or own a S281 3-Valve or H281 3-Valve (both naturally aspirated) you will need to return the vehicle to Stock Ford Mustang Status. This includes pulley, chips, programmers, etc... The vehicle will not function properly, and kit components may not fit properly if the vehicle is not returned to stock.
- Saleen recommends the use of HTO spark plugs ([Saleen Part# 00-1601-C13394*](#)) with this kit, if your vehicle is produced from 2005 to early model year 2008. The HTO spark plug will not fit vehicles produced after December 1st 2007. To verify if your vehicle will accept HTO spark plugs, inspect a spark plug coil. If the coil has a brown plastic sleeve, HTO plugs are not available. If the coil is all black and does not have a brown sleeve, HTO plugs can be ordered through Saleen for your vehicle.
- We strongly urge that you have at least one person to help you install the supercharger, as the supercharger assembly is heavy, and the hood is too awkward to position alone. With enough help and at least one read of this installation guide, you should be well on your way to one hot Mustang!
- Finally, be sure that you fill out the processor questionnaire and return it to Saleen with your PCM! We cannot flash the PCM without that questionnaire!

Again, thank you for choosing Saleen!



PARTS INCLUDED IN SERIES VI.5 S/C KIT ~ 475 HP (2005 to 2006)

Below is a list of kit items and parts unique to the 2005 to 2006 model year kit. Page V will display all of the kit items and parts universal to all kits (2005 to 2009). If you have ordered a 2005 to 2006 Mustang Series VI Supercharger Kit, the parts below are included in your kit.

A	10-1607-B138260	SERIES VI.5 SC KIT, 475 HP, 2005-06 MUSTANG	1	EACH
	06-2001-B095680	HEAT EXCHANGER KIT	1	EACH
	06-2001-C09599	HEAT EXCHANGER S/C S197 MUSTANG	1	EACH
	00-9003-C001370	JETNUT M8 x 1.25	4	EACH
	06-2001-B095710	RECOVERY TANK KIT	1	EACH
	00-2001-C099940	CAP TANK	1	EACH
	06-2001-C10212	TANK INTERCOOLER RECOVERY	1	EACH
	00-9001-C101410	CAPSCRW HEX FLNG M6x1.0mm 25mm FULL THRD Zn PL	3	EACH
	00-9004-C120070	WASHER, M6 ID 18MM OD, 18-8 SS	2	EACH
	00-9003-C109360	NUT NYLOC M6 10mm WIDTH 6mm HEIGHT	2	EACH
	06-1604-B098630	ALTERNATOR MOUNTING KIT	1	EACH
	06-1604-C09864	ALTERNATOR MOUNT MACHINED	1	EACH
	00-9003-C157270	NUT M8 X 1.25 DISTORTED THREAD LOCKNUT ZN PLATED	3	EACH
	00-9004-C157320	WASHER AN SS 5/16" ALTERNATOR MOUNT	3	EACH
	00-9002-C110890	STUD ST BLCK OX M8x1.25x110mm UNEQUAL 31mm&12mm THD LGTH	1	EACH
	00-9002-C110900	STUD, ST BLACK OXIDE, M8 x 1.25 x 65mm 20mm THRD LNGTH	1	EACH
	00-2002-C100910	STUD, ST BLACK OXIDE, M8 x 1.25 x 110mm	1	EACH
	00-9001-C106650	CAPSCRW HEX FLNG M8x1.25mm 40mm CL 8.8 FULLY THRD Zn PL	2	EACH
	00-1706-C153230	STANDOFF, ALTERNATOR WIRE	1	EACH
	00-1703-C070870	DUAL WALL HEAT SHRINK 1/2" RED	1	INCH
	06-1604-C09936	ALTERNATOR PULLEY S/C S197 MUSTANG	1	EACH
	00-9004-C111460	WASHER 17mm ID 40mm OD 1.6mm THICK Zn PL	1	EACH
	00-9003-C102610	NUT HEX JAM M16x1.5x8mm Zn PL	1	EACH
	00-3105-C115760	ALT PULLEY TOOL	1	EACH
	06-2003-C143820	GASKET, WATER CROSSOVER, DRVR, 2007 MUSTANG	1	EACH
	00-2003-C19338	COOLANT HOSE ASSEMBLY	1	EACH
	00-2003-C19363	THERMOSTAT 2007 to 2010	1	EACH
	06-2003-C143810	O-RING, THERMOSTAT	1	EACH
	00-1703-C070870	DUAL WALL HEAT SHRINK 1/2" RED	3	INCH
	00-1704-C110830	SLEEVING, CONVOLUTED 1/2" BLACK	8.5	INCH
	00-1704-C063000	HEAT SHRINK, DUAL WALL 1/8" BLACK	13.5	INCH
	00-1703-C070810	WIRE, 4 AWG RED	10	INCH
	00-1703-C162470	SPLICE, NON-INSULATED SEAMLESS 6 AWG BUTT	1	EACH
	00-1703-C070900	TERMINAL, RING 4 AWG FOR 1/4" STUD	1	EACH
	00-1704-C093820	WIRE, 20 AWG YELLOW	12.25	INCH
	00-1704-C129750	WIRE, 20 AWG YELLOW/BLUE	12.25	INCH
	00-1704-C157540	WIRE, 20 AWG ORANGE/BLUE	12.25	INCH
	00-1704-C092600	SPLICE, NON-INSULATED SEAMLESS 18-20 AWG BUTT	9	EACH



PARTS INCLUDED IN SERIES VI.5 S/C KIT ~ 475 HP (2007 to 2008)

Below is a list of kit items and parts unique to the 2007 to 2008 model year kit. Page V will display all of the kit items and parts universal to all kits (2005 to 2009). If you have ordered a 2007 to 2008 Mustang Series VI Supercharger Kit, the parts below are included in your kit.

B	10-1607-B150580	SERIES VI.5 SC KIT, 475 HP, 2007-08 MUSTANG, A/M	1	EACH
	06-2001-B150880	HEAT EXCHANGER KIT	1	EACH
	06-2001-C09599	HEAT EXCHANGER S/C S197 MUSTANG	1	EACH
	00-9003-C157270	NUT M8 X 1.25 DISTORTED THREAD LOCKNUT ZN PLATED	4	EACH
	00-9004-C001740	WASHER FLAT M8 ST	4	EACH
	00-9001-C135810	BOLT M8x1.25mm 30mm CL 8.8 Zn PL FLANGE	2	EACH
	00-9004-C114890	WASHER FLAT M8 24mm OD 2mm THK Zn PL	2	EACH
	06-2001-B095710	RECOVERY TANK KIT	1	EACH
	00-2001-C099940	CAP TANK	1	EACH
	06-2001-C10212	TANK INTERCOOLER RECOVERY	1	EACH
	00-9001-C101410	CAPSCRW HEX FLNG M6x1.0mm 25mm FULL THRD Zn PL	3	EACH
	06-1604-B098630	ALTERNATOR MOUNTING KIT	1	EACH
	06-1604-C09864	ALTERNATOR MOUNT MACHINED	1	EACH
	00-9003-C157270	NUT M8 X 1.25 DISTORTED THREAD LOCKNUT ZN PLATED	3	EACH
	00-9004-C157320	WASHER AN SS 5/16" ALTERNATOR MOUNT	3	EACH
	00-9002-C110890	STUD ST BLCK OX M8x1.25x110mm UNEQUAL 31mm&12mm THD LGTH	1	EACH
	00-9002-C110900	STUD, ST BLACK OXIDE, M8 x 1.25 x 65mm 20mm THRD LNGTH	1	EACH
	00-2002-C100910	STUD, ST BLACK OXIDE, M8 x 1.25 x 110mm	1	EACH
	00-9001-C106650	CAPSCRW HEX FLNG M8x1.25mm 40mm CL 8.8 FULLY THRD Zn PL	2	EACH
	00-1706-C153230	STANDOFF, ALTERNATOR WIRE	1	EACH
	00-1703-C070870	DUAL WALL HEAT SHRINK 1/2" RED	1	INCH
	06-1604-C09936	ALTERNATOR PULLEY S/C S197 MUSTANG	1	EACH
	00-9004-C111460	WASHER 17mm ID 40mm OD 1.6mm THICK Zn PL	1	EACH
	00-9003-C102610	NUT HEX JAM M16x1.5x8mm Zn PL	1	EACH
	00-3105-C115760	ALT PULLEY TOOL	1	EACH
	06-2003-C143790	HOSE, UPPER RAD PASS, 2006 MUSTANG	1	EACH
	00-1703-C070870	DUAL WALL HEAT SHRINK 1/2" RED	3	INCH
	00-1704-C110830	SLEEVING, CONVOLUTED 1/2" BLACK	8.5	INCH
	00-1704-C063000	HEAT SHRINK, DUAL WALL 1/8" BLACK	13.5	INCH
	00-1703-C070810	WIRE, 4 AWG RED	10	INCH
	00-1703-C162470	SPLICE, NON-INSULATED SEAMLESS 6 AWG BUTT	1	EACH
	00-1703-C070900	TERMINAL, RING 4 AWG FOR 1/4" STUD	1	EACH
	00-1704-C093820	WIRE, 20 AWG YELLOW	12.25	INCH
	00-1704-C129750	WIRE, 20 AWG YELLOW/BLUE	12.25	INCH
	00-1704-C157540	WIRE, 20 AWG ORANGE/BLUE	12.25	INCH
	00-1704-C092600	SPLICE, NON-INSULATED SEAMLESS 18-20 AWG BUTT	9	EACH



PARTS INCLUDED IN SERIES VI.5 S/C SUPPLEMENTAL KIT ~ 2009

Below is a list of kit items and parts unique to the 2009 model year. Page V will display all of the kit items and parts universal to all kits (2005 to 2009). If you are installing a Saleen Series VI.5 Supercharger Kit on a 2009 Mustang, the parts below are included in the supplemental kit. Otherwise, the kit is the same as a 2007-2008 kit.

C	06-1604-B19222	2009 SUPPLEMENTAL KIT, SUPERCHARGER	1	EACH
	06-1604-C18921	ALTERNATOR PULLEY S/C S197 2009	1	EACH
	00-9004-C18923	WASHER, M14 FLAT	1	EACH
	00-9003-C18922	NUT, HEX M14x1.50	1	EACH
	00-1607-C146160	GASKET, INTAKE MANIFOLD TO HEAD, MUSTANG	8	EACH



PARTS INCLUDED IN SERIES VI.5 S/C KIT ~ 475 HP (UNIVERSAL)

Below is a list of kit items and parts that are universal to all model year kits (2005 to 2009)

06-2002-B095960	WATER PUMP KIT	1	EACH
00-2002-C099910	INTERCOOLER WATER PUMP, '05 S281	1	EACH
06-2002-C09888	BRACKET WATER PUMP 05 S281	1	EACH
00-9001-C100640	CAPSCRW HEX FLNG M8x1.25mm 20mm CL 8.8 FULL THRD Zn PL	1	EACH
00-9003-C157270	NUT M8 X 1.25 DISTORTED THREAD LOCKNUT ZN PLATED	2	EACH
00-9004-C001740	WASHER FLAT M8 ST	2	EACH
00-9001-C114650	CAPSCRW HEX HD M8x1.25x50 FULL THRD Cl 10.9 Zn PL	2	EACH
00-9004-C114890	WASHER FLAT M8 24mm OD 2mm THK Zn PL	2	EACH
06-2002-C11237	SPACER WATER PUMP BRACKET	2	EACH
06-1704-B16574	HARNESS, '05-'09 MUSTANG (S281 SC & S281 E) WATER PUMP	1	EACH
06-2003-B098560	HOSE KIT S/C 4.6 3V	1	EACH
06-2003-C09857	MOLDED HOSE S/C TANK TO PUMP	1	EACH
069-950	3/4" HEATER HOSE	7.5	INCH
06-2003-C09860	MOLDED HOSE S/C INTERCOOLER TO TANK	1	EACH
06-2003-C09861	MOLDED HOSE S/C H.E TO INTERCOOLER	1	EACH
00-2003-C100680	HOSE CLAMP MOLDED HOSE S/C 2005 MUSTANG	8	EACH
06-2003-B19367	WATER CROSSOVER KIT - SERIES VI.5	1	EACH
00-9001-C101410	CAPSCRW HEX FLNG M6x1.0mm 25mm	4	EACH
00-9001-C19336	CAPSCRW HEX FLNG M6x1.0mm 80mm	1	EACH
00-9001-C19335	CAPSCRW HEX FLNG M6x1.0mm 60mm	1	EACH
00-9004-C19337	M6 WASHER	2	EACH
069-950	3/4" HEATER HOSE	6	INCH
00-2003-C100680	3/4" HOSE CLAMP	2	EACH
00-2003-C19335	WATER NECK, WATER CROSSOVER	1	EACH
00-2003-C19336	WATER CROSSOVER SERIES VI.5	1	EACH
00-1607-B19330	SUPERCHARGER SERIES VI.5 ASSEMBLY, 475 H.P., S197 MUSTANG	1	EACH
06-1704-B12563	HARNESS, '05-'09 MUSTANG (S281 SC & S281 E) ACT CONNECTOR	1	EACH
06-1602-C15559	AIR INLET DUCT	1	EACH
06-1602-C13093	AIR BOX COVER 2006 S281	1	EACH
00-1701-C120760	FUEL INJECTOR	8	EACH
00-9001-C101410	CAPSCRW HEX FLNG M6x1.0mm 25mm FULL THRD Zn PL	12	EACH
00-9005-C18840	SPRING CLAMP, 7/16IN SS	1	EACH
00-1604-C111700	GOODYEAR GATERBACK 109.0" 6 RIB BELT	1	EACH
06-2003-C09925	WATER TUBE MUSTANG	1	EACH
178-428	ALTERNATOR IDLER PULLEY, 76MM	1	EACH
00-1604-C099580	IDLER PULLEY, 76MM, GUIDED	1	EACH
10-8003-C12466	STICKER NEON ORANGE 3"x11.5" PCM BOX	1	EACH
10-8003-C12239	(BOX) PCM 2005 MUSTANG	1	EACH
06-9101-C11353	LABEL BELT DIAGRAM SC	1	EACH
069-703	14" ZIP TIE	1	EACH
00-9007-C10122*	7" ZIP TIE	4	EACH



TOOLS REQUIRED FOR KIT INSTALLATION:

3/8" Drive - Torque Wrench	90 Degree Pick
3/8" Drive - Ratchet	Panel Puller
3/8" Drive - 6" Extension	Short Phillips Head Screwdriver
5mm Socket	Flat Blade Screwdriver
12mm Deep Socket	Wire Stripper / Crimper
13mm Deep Socket	Heat Gun (For Heat Shrink)
15mm Socket	Air Saw or Hack Saw
3/8" Deep Socket	Coolant System Pressure Tool
13mm Ratcheting wrench	2 Gallon Bucket
1/4" Drive - Torque Wrench	Hose Clamp Pliers
1/4" Drive - Ratchet	Pliers
1/4" Drive - 8" Extension	Fiber Stick
5.5mm Socket (1/4" Drive)	1/2" Drive Impact
8mm Socket (1/4" Drive)	1/2" Drive Breaker Bar
8mm Deep Socket (3/8" Drive)	1/2" Drive 17mm Impact Socket
10mm Socket (1/4" Drive) Deep Socket	1/2" Drive 24mm Impact Socket
10mm Socket (1/4" Drive) Shallow Swivel Socket	1/2" Drive 22mm Impact Socket
3/8" Drive 5/16" Allen Tool	Fuel Line Disconnect Tool
3/8" Drive 5mm Allen Tool	Blue Loctite
3/8" Drive 6mm Allen Tool	Red Loctite
1/4" Drive 3/16" Allen Tool	Pen Light
1/4" Drive 4mm Allen Tool	Mechanics Magnet
T15 Torx Bit	

NOTE: If you do not have any of the tools listed above, you may be able to obtain them from your local tool lending service

TORQUE

ITEM

OPERATION

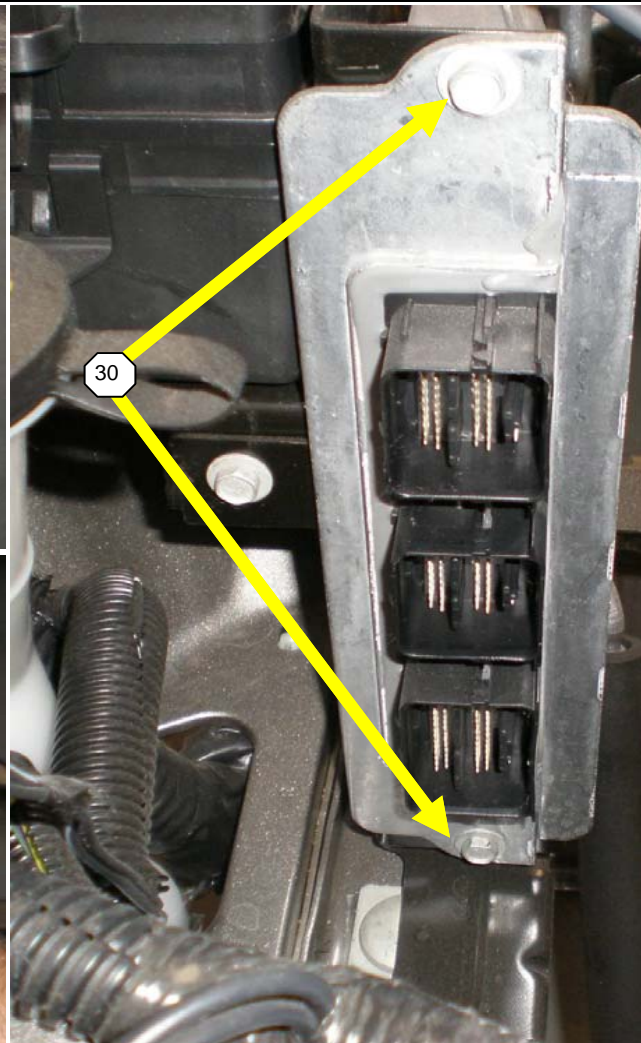
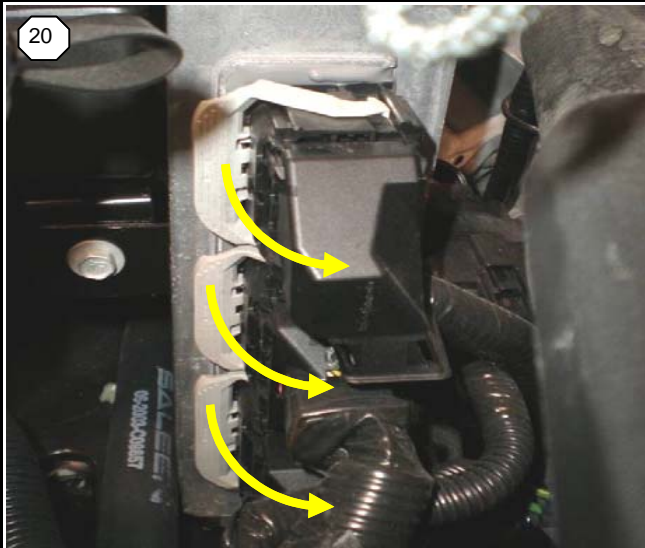

- 10 The PCM is located under the hood next to the fuse box and forward of the battery.
- 20 Pull back on the grey plastic locking tab for each electrical connector and disconnect the connectors from the PCM by carefully pulling on them.
- 30 With a 10mm socket, remove the 2 bolts holding the PCM to its mounting bracket.
- 40 Pull the PCM towards the front of the vehicle to remove.
- 50 Fill out the PCM questionnaire on the following page **COMPLETELY**, including the address to which you want the PCM returned to, and send it to the following address...

Saleen, Attn: PCM Programming
33603 Dequindre Rd.
Troy, MI 48083

If you have any issues, please call **1.800.888.8945 ext 2101**

ITEM	PART NUMBER	QTY.	DESCRIPTION
A	10-8003-C12466	1	Sticker Orange 3"x11.5" PCM Box
B	10-8003-C12239	1	(BOX) PCM Mustang

NOTES:

TORQUE



PROCESS PAGE

REMOVE PCM

TORQUE

ITEM

OPERATION

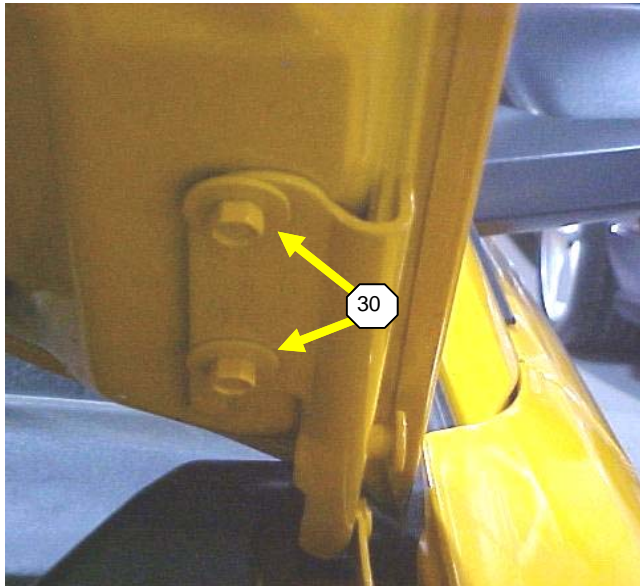
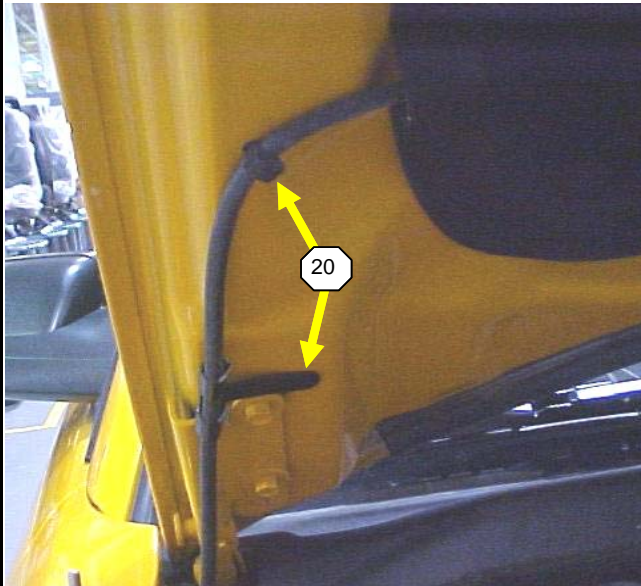
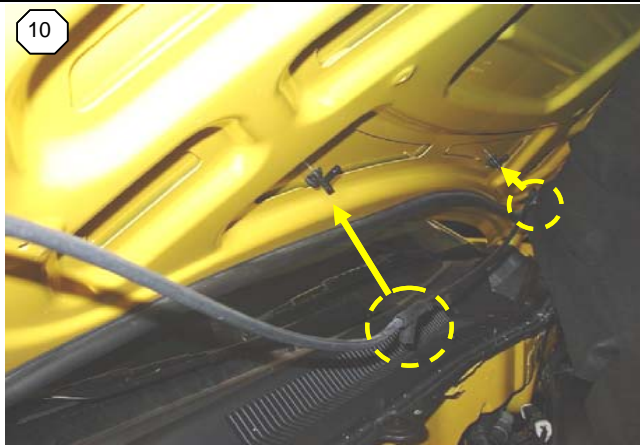

10 Locate the windshield washer sprayer hose (located underneath the hood liner) and disconnect the line from the sprayers. There is a rubber T-fitting on the RH side (passenger) and an elbow on the LH side (driver). Then remove the sprayers.

20 Remove the two clips holding the windshield washer sprayer line to the hood with a panel puller. The clips are located near the RH side (passenger) hood hinge. Once the sprayer line is fully disconnected from the hood, set the hose aside out of the way.

30 While another person helps hold the hood, carefully remove the four 10mm bolts (2 per side) that attach the hood to the hinge. Once the hood is free of the hinges, carefully set the hood aside where it cannot get damaged.

NOTICE: The hood liner may need to be partially removed to reach the sprayer T-fittings. To remove the tree clips, use a panel puller.

ITEM	PART NUMBER	QTY.	DESCRIPTION

NOTES:

TORQUE



PROCESS PAGE

REMOVE HOOD



TORQUE



ITEM



OPERATION

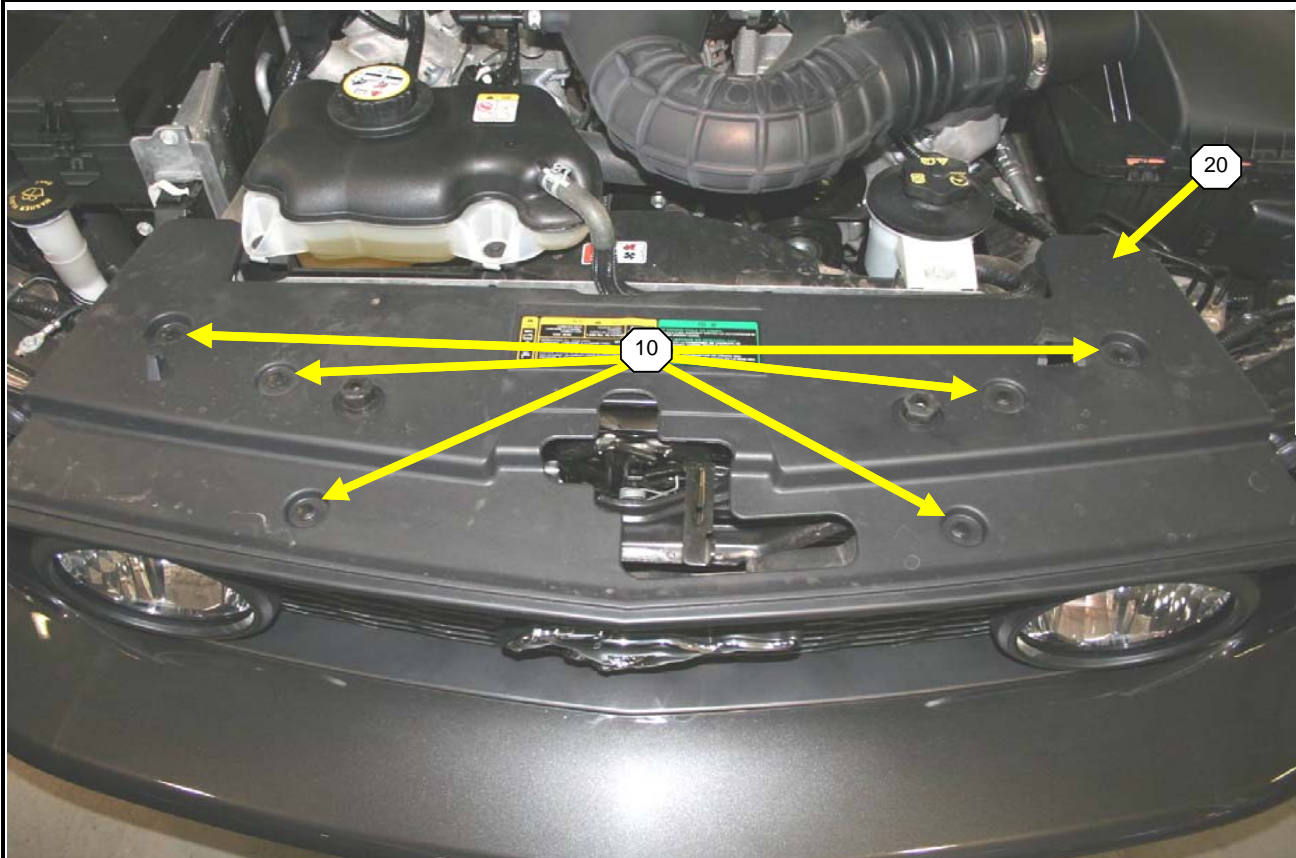

10

With a panel puller, remove the 6 retainer pins holding the top aero shield in place.

20

Remove the aero shield.

ITEM	PART NUMBER	QTY.	DESCRIPTION

NOTES:

TORQUE



PROCESS

PAGE

REMOVE FRONT FASCIA

STOCK MUSTANG GT

E

TORQUE

ITEM

OPERATION

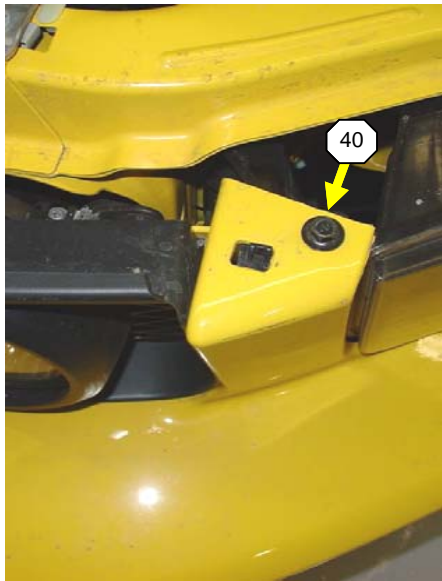
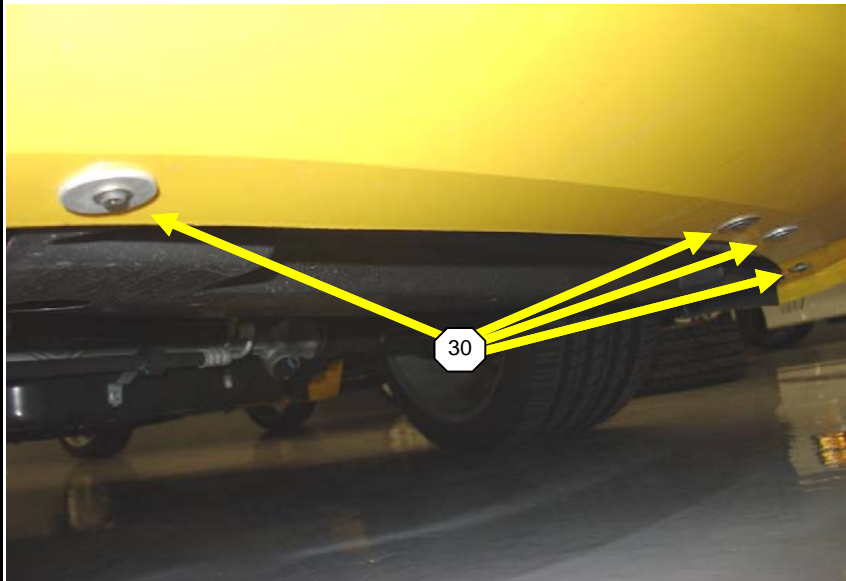
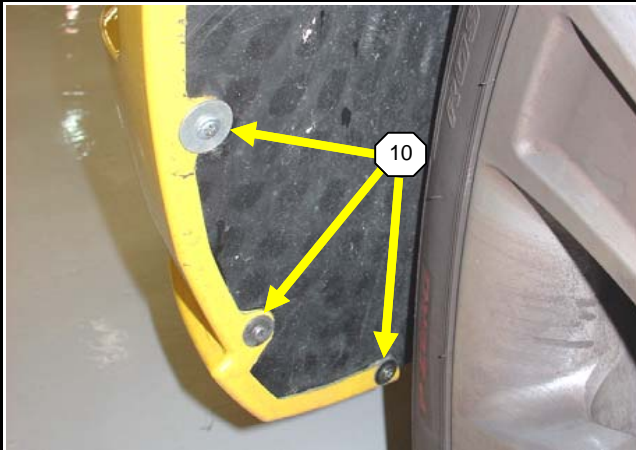

10 Both wheel wells have Philips screws (3 per side) that need to be removed. The front wheels may need to be turned left or right to obtain the necessary clearance for the screw driver.

20 Once the screws are removed, pull the fender liners back towards the front wheels enough to see the 10mm nuts (2 per side) fastening the front fascia to each fender. Remove all 4 of the nuts.

30 Underneath the front fascia in the front along the leading edge are four 5.5mm bolts attaching the lower aero shield to the bottom of the fascia. Remove the bolts.

40 Remove the 10mm bolts (1 per side) attaching the top of the front fascia to the car. Each bolt is located just inboard of the headlight.

ITEM	PART NUMBER	QTY.	DESCRIPTION

NOTES:

TORQUE



PROCESS PAGE

REMOVE FRONT FASCIA

STOCK MUSTANG GT

TORQUE

ITEM

OPERATION

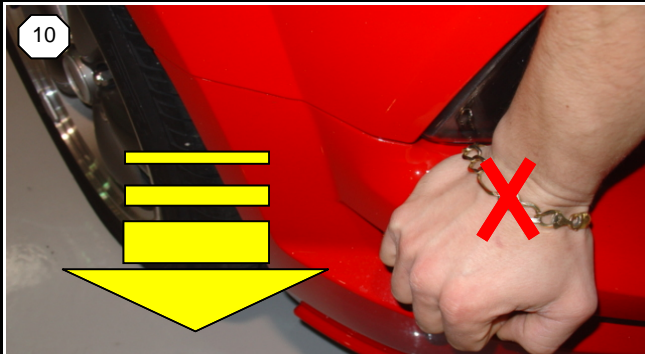

DO NOT WEAR WATCHES, RINGS, BRACELETS, OR OTHER JEWELRY THAT MAY SCRATCH PAINTED PARTS DURING DISASSEMBLY OR ASSEMBLY

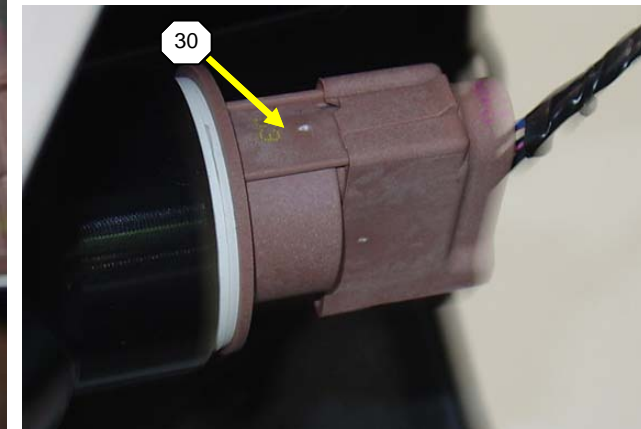
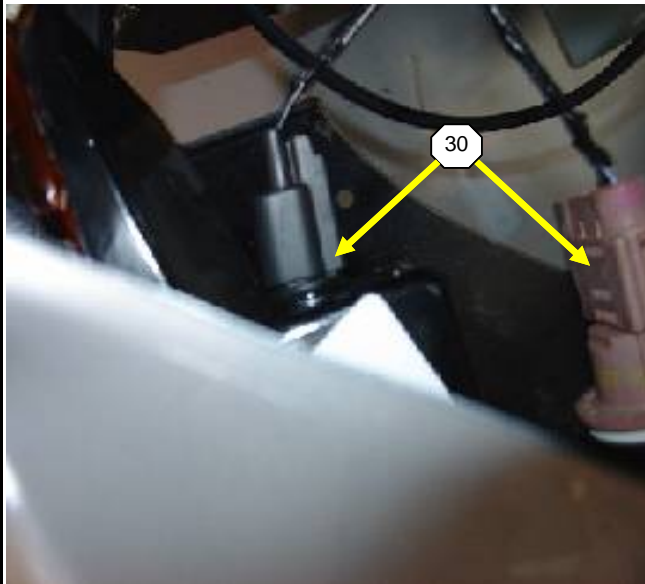
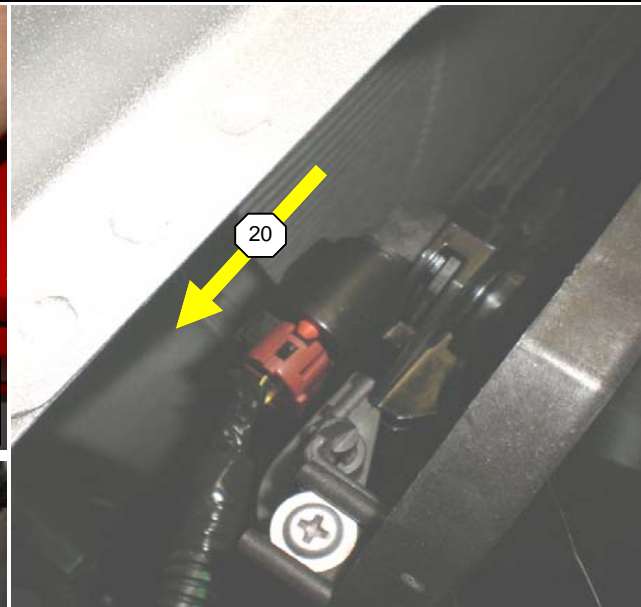

10 Once all of the fasteners are removed, remove the front fascia by placing the palm of your hand on each side of the front fascia and push down until the fascia loosens. Let the fascia sit on the front bumper in order to disconnect harnesses.

20 Press in the tab located on the side of each fog lamp connector (1 per side). Once the tab is depressed, pull each fog lamp connector away from the lamp housing to disconnect.

30 Disconnect the side marker lamp connectors and the turn signal connectors (1 of each per side, located underneath each head lamp). To disconnect each connector, depress the tab and pull to separate.

40 Remove front fascia and set it where it will not get scratched or damaged.

ITEM	PART NUMBER	QTY.	DESCRIPTION

NOTES:

TORQUE



PROCESS PAGE

REMOVE FRONT FASCIA

STOCK MUSTANG GT

E



TORQUE



ITEM



OPERATION

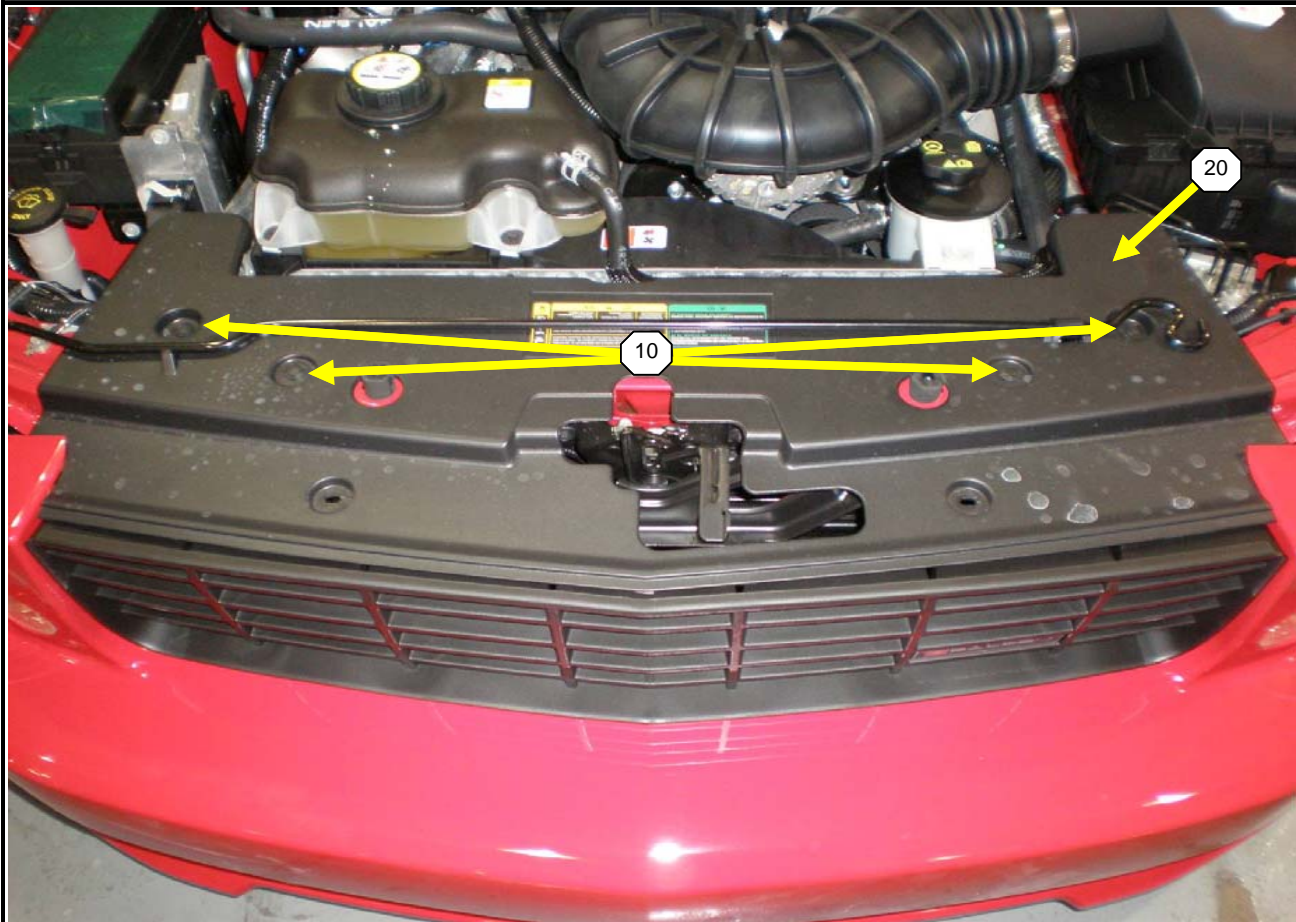

10

With a panel puller, remove the 4 retainer pins holding the top aero shield in place.

20

Remove the aero shield.

ITEM	PART NUMBER	QTY.	DESCRIPTION

NOTES:

TORQUE



PROCESS

REMOVE FRONT FASCIA

SALEEN S-SERIES

PAGE

F

5

TORQUE

ITEM

OPERATION

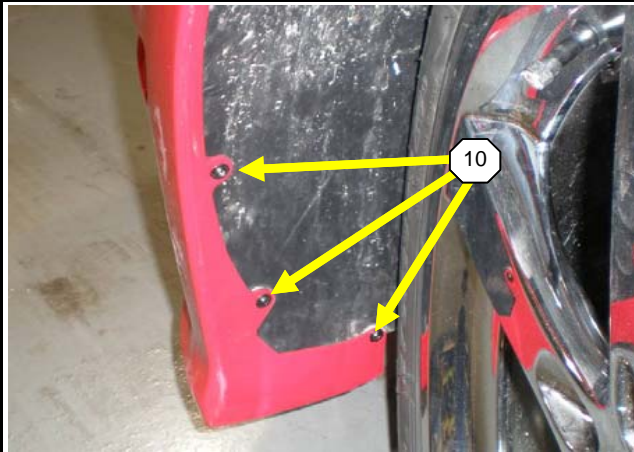

- 10 Both wheel wells have Philips screws (3 per side) that need to be removed. The front wheels may need to be turned left or right to obtain the necessary clearance for the screw driver.
- 20 Once the screws are removed, pull the fender liners back towards the front wheels enough to see the 10mm nuts (2 per side) fastening the front fascia to each fender. Remove all 4 of the nuts.
- 30 Underneath the front fascia in the front along the leading edge are two 5.5mm bolts attaching the lower aero shield to the bottom of the fascia. Remove the bolts.
- 40 Remove the 10mm bolts (1 per side) attaching the top of the front fascia to the car. Each bolt is located just inboard of the headlight.

ITEM	PART NUMBER	QTY.	DESCRIPTION

NOTES:

TORQUE			PROCESS	PAGE
		REMOVE FRONT FASCIA		F
		<u>SALEEN S-SERIES</u>		
				6

TORQUE

ITEM

OPERATION

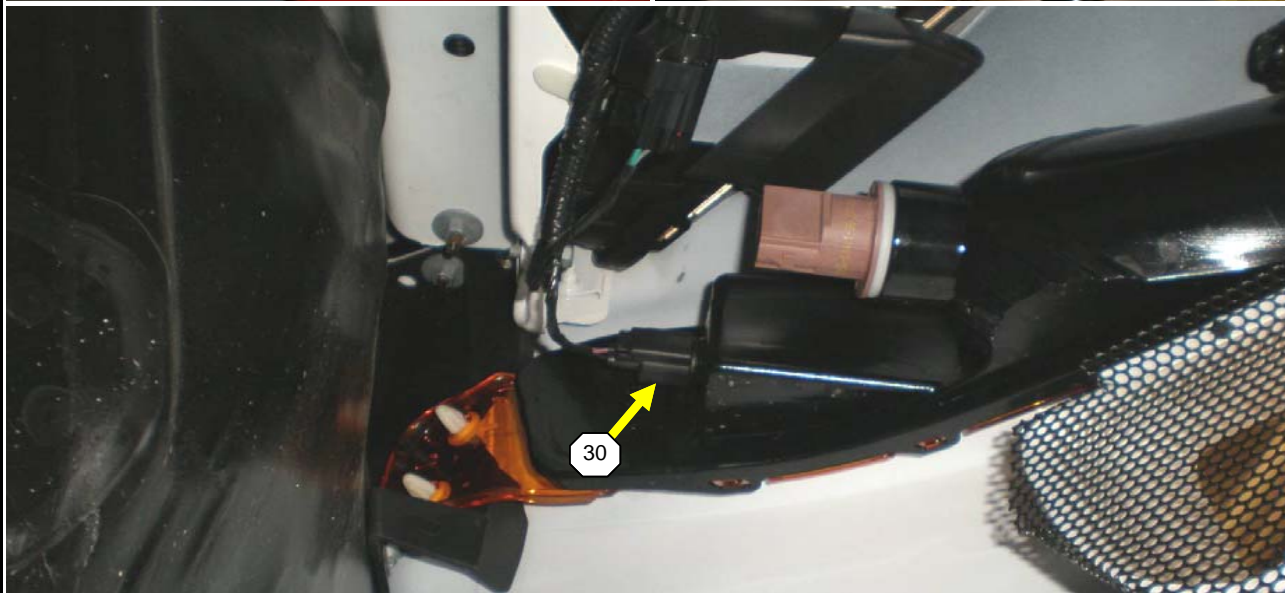
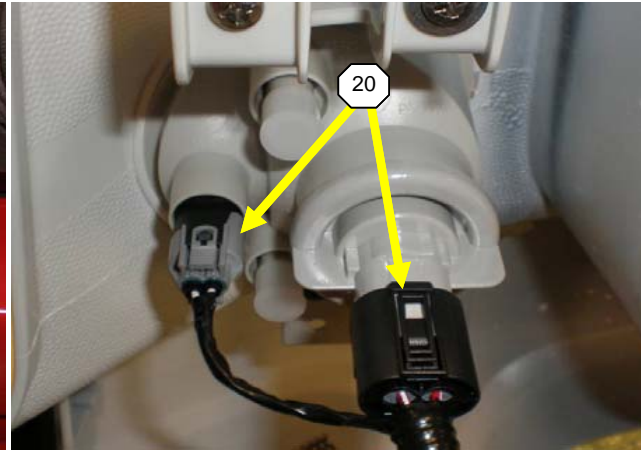

10 Once all of the fasteners are removed, remove the front fascia by placing the palm of your hand on each side of the front fascia and push down until the fascia loosens. Let the fascia sit on the front bumper in order to disconnect harnesses.

20 Locate the turn signal harness (located behind each turn signal, at each side of the front grille). Disconnect each connector by depressing the tab and pulling the connector away from the turn signal housing.

30 Disconnect the side marker lamp connectors (located underneath each head lamp). To disconnect each connector, depress the tab and pull to separate.

40 Remove front fascia and set it where it will not get scratched or damaged.

ITEM	PART NUMBER	QTY.	DESCRIPTION

NOTES:

TORQUE



PROCESS

REMOVE FRONT FASCIA

SALEEN S-SERIES

PAGE

F

7



TORQUE



ITEM



OPERATION

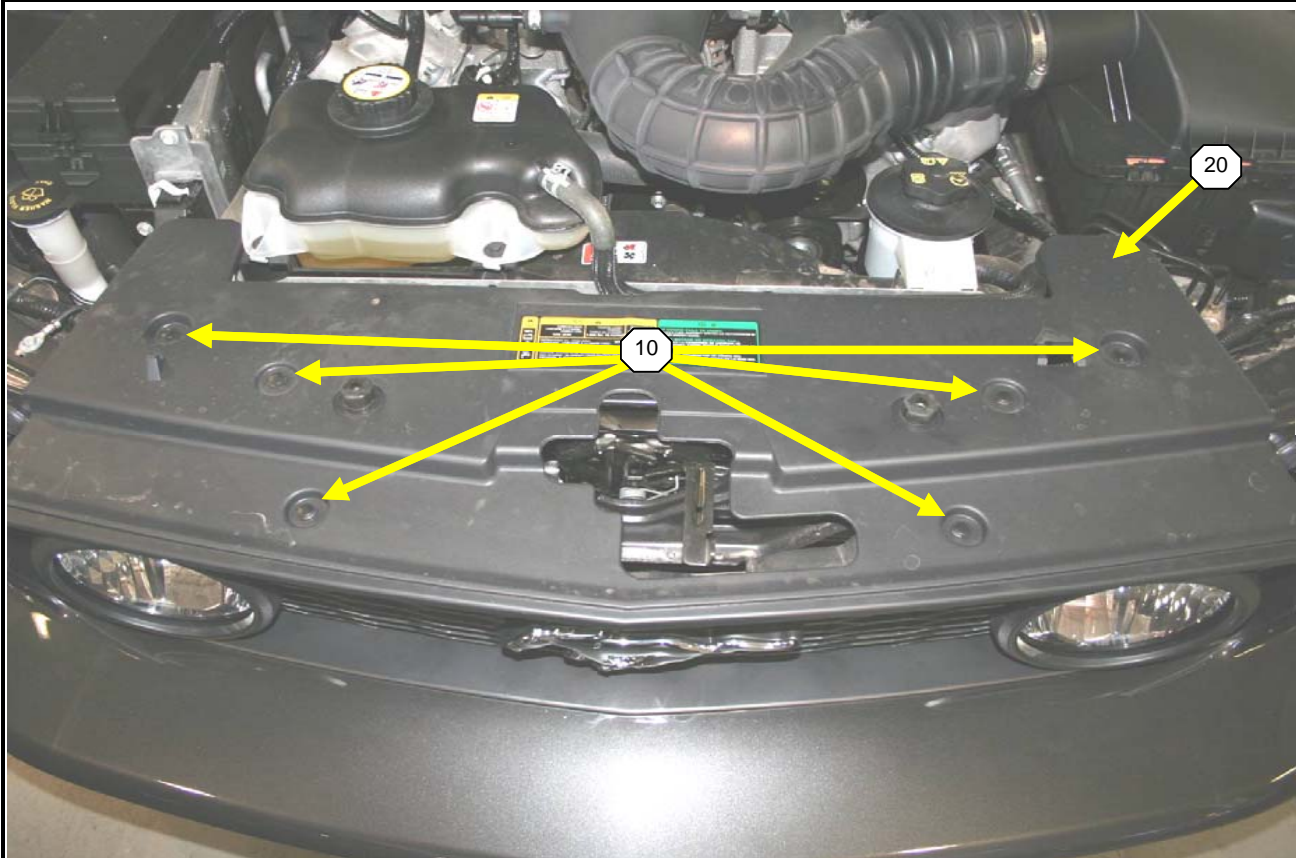

10

With a panel puller, remove the 6 retainer pins holding the top aero shield in place.

20

Remove the aero shield.

ITEM	PART NUMBER	QTY.	DESCRIPTION

NOTES:

TORQUE



PROCESS

REMOVE FRONT FASCIA

SALEEN H-SERIES

PAGE

G

5



TORQUE



ITEM



OPERATION

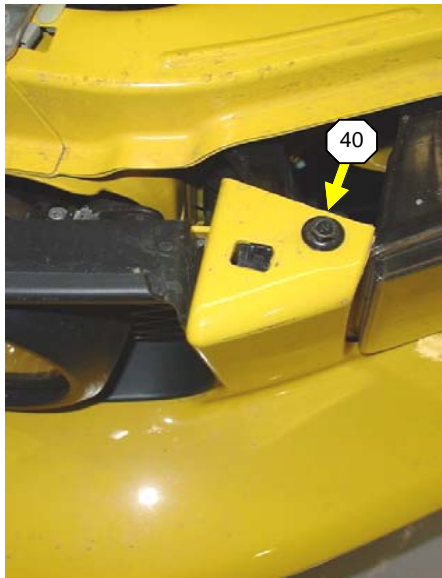
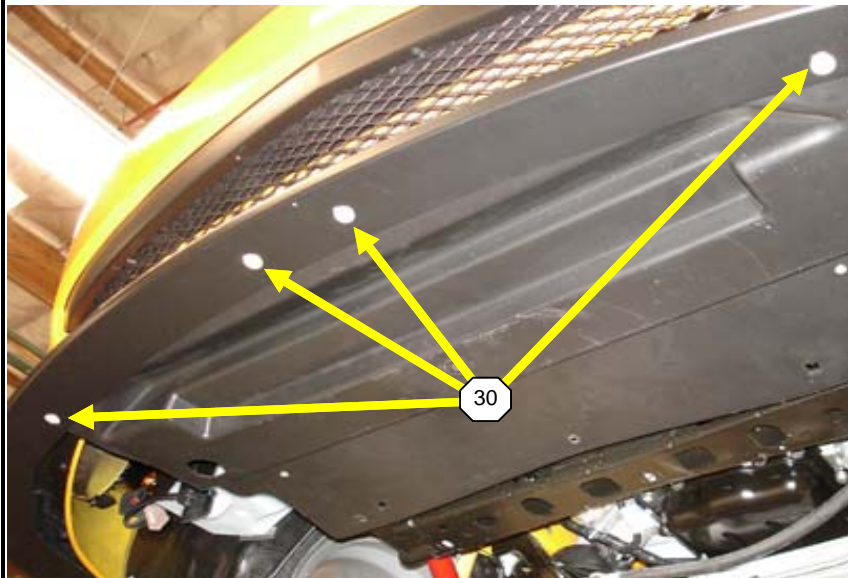
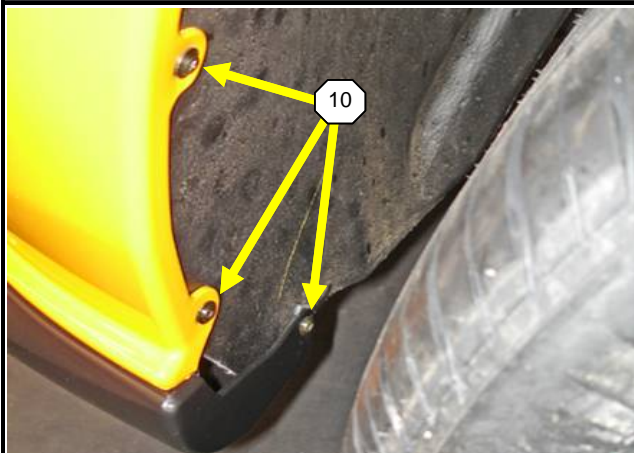

10

Both wheel wells have Philips screws (3 per side) that need to be removed. The front wheels may need to be turned left or right to obtain the necessary clearance for the screw driver.

20

Once the screws are removed, pull the fender liners back towards the front wheels enough to see the 10mm nuts (2 per side) fastening the front fascia to each fender. Remove all 4 of the nuts.

30

Underneath the front fascia in the front along the leading edge are four 5.5mm bolts attaching the lower aero shield to the bottom of the fascia. Remove the bolts.

40

Remove the 10mm bolts (1 per side) attaching the top of the front fascia to the car. Each bolt is located just inboard of the headlight.

ITEM	PART NUMBER	QTY.	DESCRIPTION

NOTES:

TORQUE



PROCESS PAGE

REMOVE FRONT FASCIA

SALEEN H-SERIES

TORQUE

ITEM

OPERATION

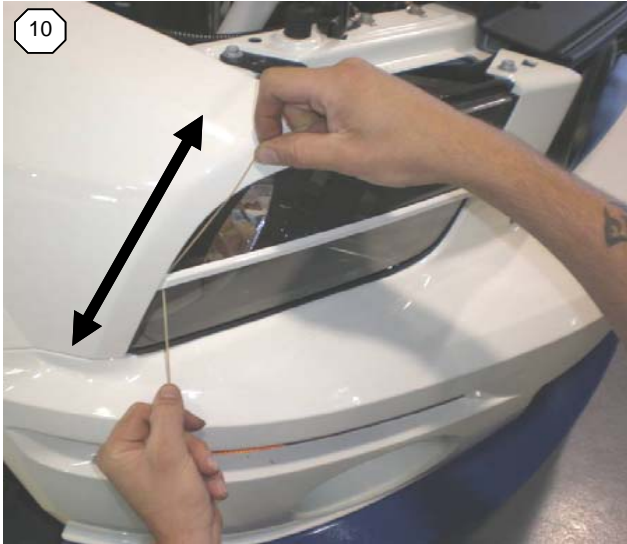

DO NOT WEAR WATCHES, RINGS, BRACELETS, OR OTHER JEWELRY THAT MAY SCRATCH PAINTED PARTS DURING DISASSEMBLY OR ASSEMBLY

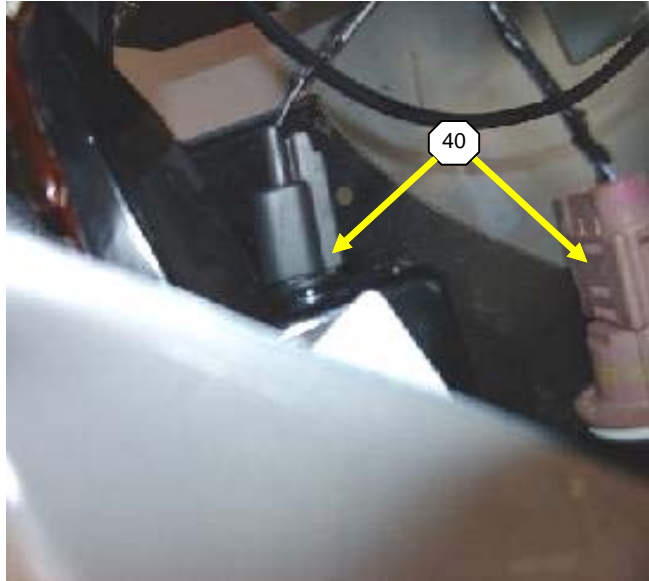
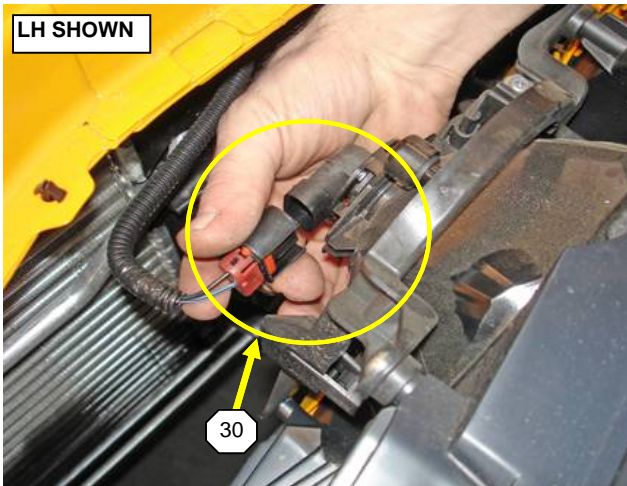

- 10 Retrieve some plastic fishing line. Feed the fishing line behind each headlamp bar, and move the line in a saw like motion (up and down) while pulling the line across the headlamp. Continue this process until each headlamp bar is separated from the headlamps.
 - 20 Remove the front fascia by placing the palm of your hand on each side of the front fascia and push down until the fascia loosens. Let the fascia sit on the front bumper in order to disconnect harnesses.
 - 30 Press in the tab located on the side of each fog lamp connector (1 per side). Once the tab is depressed, pull each fog lamp connector away from the lamp housing to disconnect.
 - 40 Disconnect the side marker lamp connectors and the turn signal connectors (1of each per side, located underneath each head lamp). To disconnect each connector, depress the tab and pull to separate.
 - 50 Remove front fascia and set it where it will not get scratched or damaged.
- NOTICE:** Use only plastic fishing line to remove the each headlamp bar from its headlamp. Once the fascia is removed, clean any tape residue from the headlamp and the fascia bar.

LH SHOWN

NOTES:

ITEM	PART NUMBER	QTY.	DESCRIPTION

TORQUE			PAGE
PROCESS			
REMOVE FRONT FASCIA		G	
SALEEN H-SERIES			
		7	



TORQUE



ITEM



OPERATION

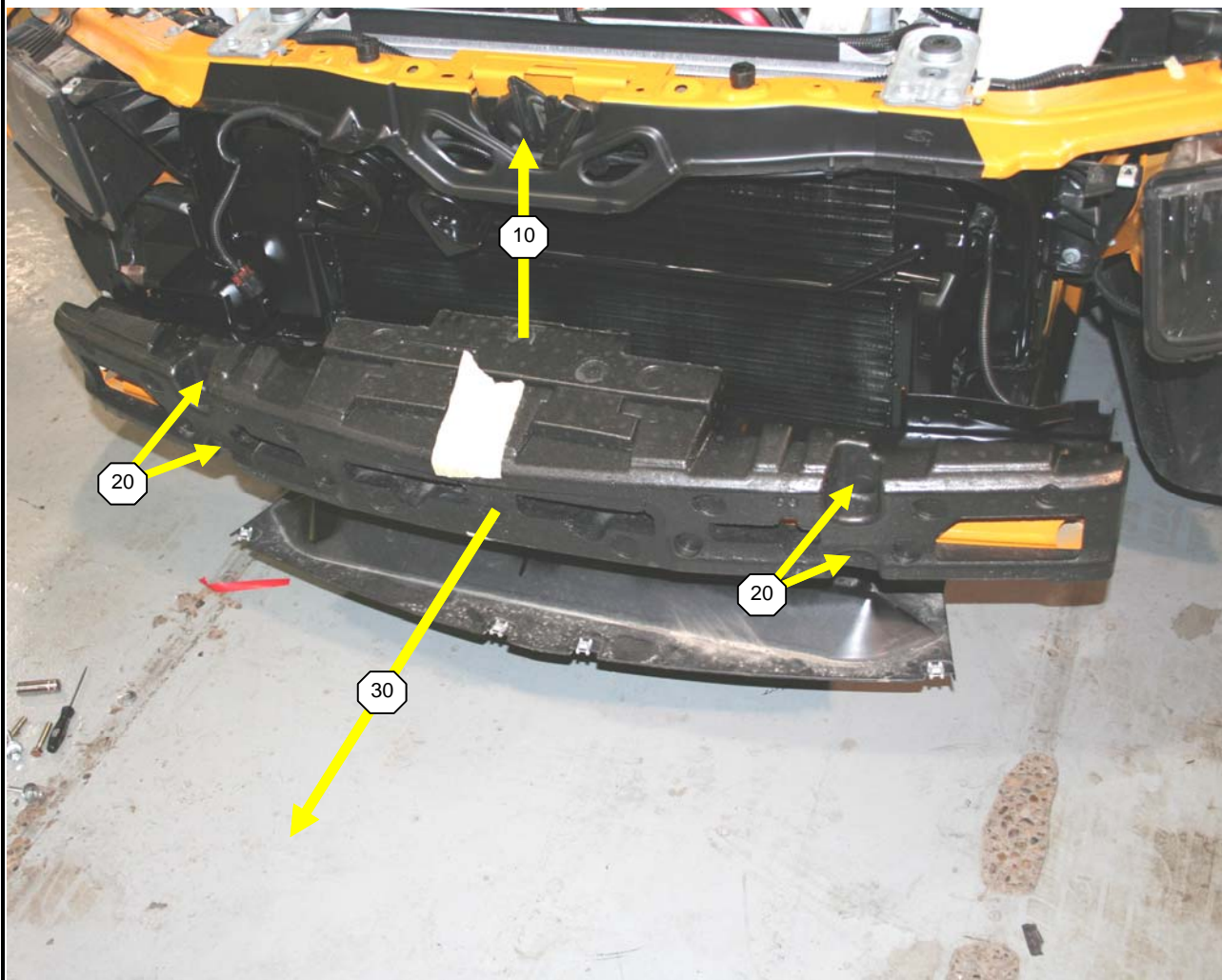

- 10 Remove the top isolator pad by lifting up on it.
- 20 With a panel puller, remove the 4 tree clips holding the main front bumper isolator to the front bumper.
- 30 There are foam studs on the back side of the isolator that locate into the bumper, so pull the main isolator forward to remove.

ITEM	PART NUMBER	QTY.	DESCRIPTION

NOTES:

TORQUE



PROCESS PAGE

REMOVE ISOLATOR

TORQUE

ITEM

OPERATION

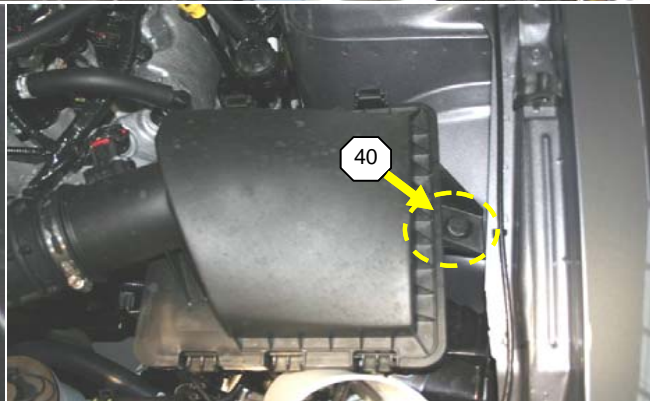
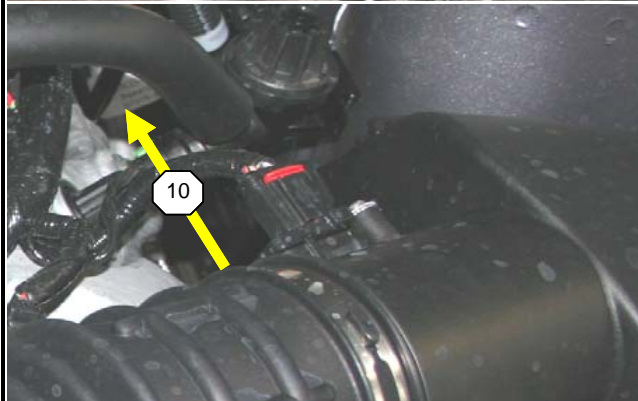

- 10 Pull the red tab on the top of the MAF connector away from the air box lid to un-lock the connector. Depress the tab on the top of the connector, and disconnect.
- 20 Disconnect the crankcase vent tube from the snorkel (just forward of the throttle body). Push on the green locking tab, and pull the vent tube away from the snorkel.
- 30 With a flat blade screwdriver, loosen the clamp that secures the air box snorkel to the throttle body.
- 40 Using a 10mm socket, remove the bolt securing the air box to the driver side inner fender. Save the bolt, it will be re-used later.
- 50 Lift the intake assembly (snorkel and air box together) out of the vehicle and set aside.

ITEM	PART NUMBER	QTY.	DESCRIPTION

NOTES:

TORQUE



PROCESS PAGE

REMOVE INTAKE SNORKEL AND AIR BOX

TORQUE

ITEM

OPERATION

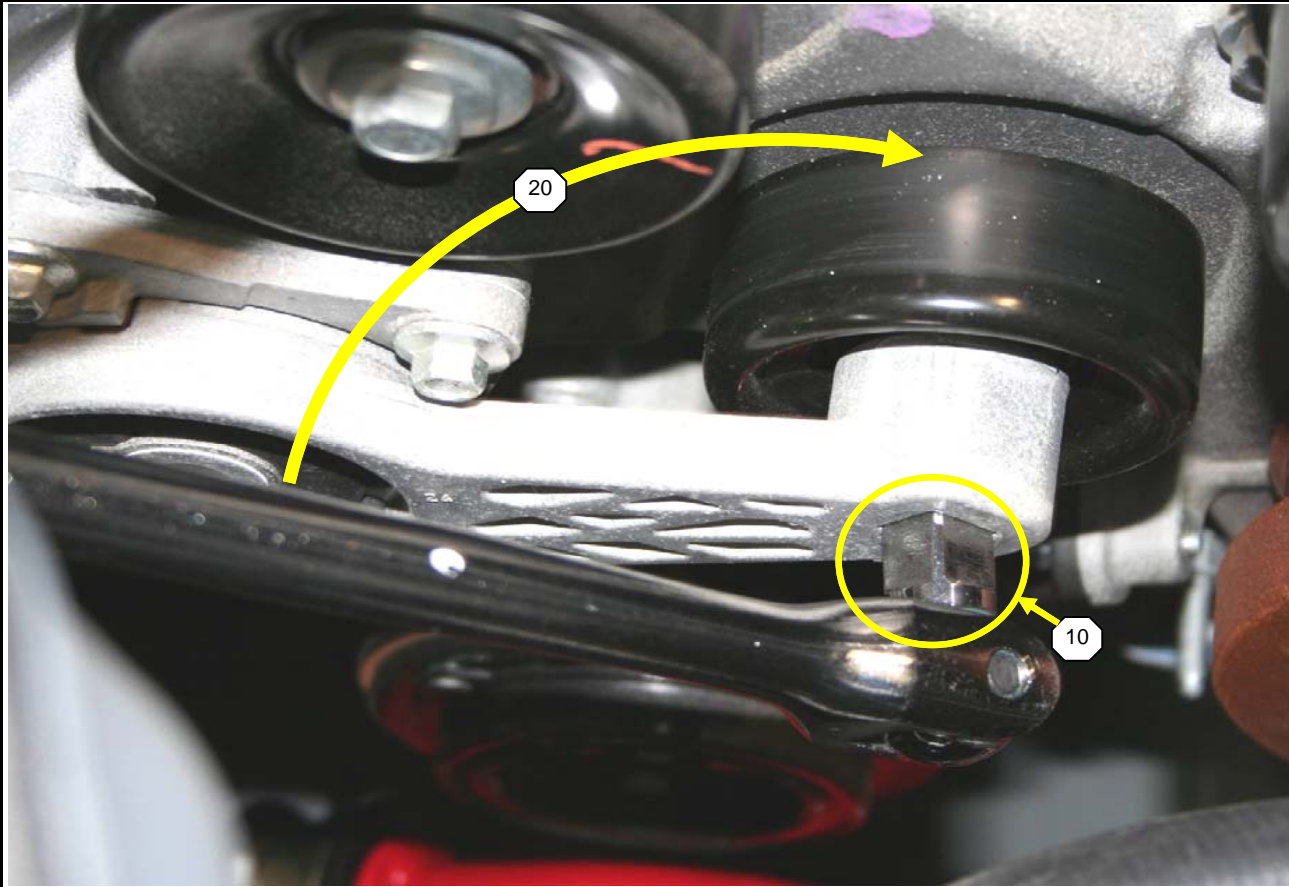

10

Insert a 1/2" drive breaker bar into the arm of the belt tensioner. and remove the belt.

20

Pull the breaker bar towards the driver side of the vehicle to release the tension on the belt.

30

While the tensioner is engaged, slide the belt off of the pulleys and removed.

ITEM	PART NUMBER	QTY.	DESCRIPTION

NOTES:

TORQUE



PROCESS PAGE

REMOVE SERPENTINE BELT

TORQUE

ITEM

OPERATION

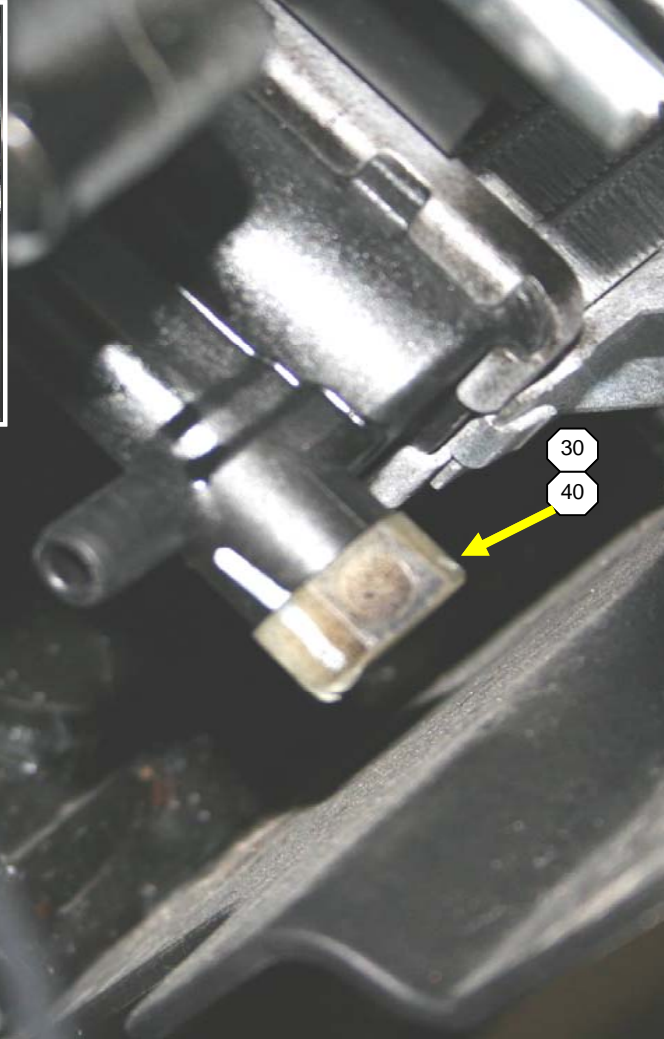
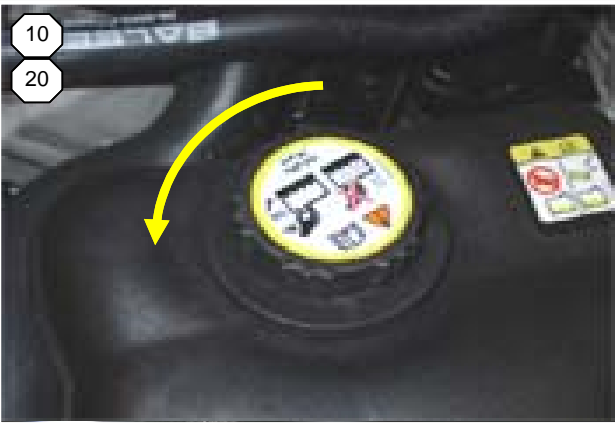

NOTES:

- 10 Release the pressure in the coolant system by locating the pressure relief cap and slowly turning it 1/2 turn counter-clockwise.
 - 20 Once pressure is relieved, remove cap.
 - 30 Find a suitable container below the radiator petcock drain (located bottom passenger side), and use a 19mm to open the valve and drain coolant.
- NOTICE:** If a coolant vacuum machine is available, it can be used to extract the coolant by hooking the vacuum line to the petcock and then vacuuming out the coolant reservoir bottle.
- 40 Once the coolant is done draining, re-tighten the petcock drain.

ITEM	PART NUMBER	QTY.	DESCRIPTION

TORQUE



PROCESS PAGE

REMOVE ENGINE COOLANT



TORQUE



ITEM



OPERATION

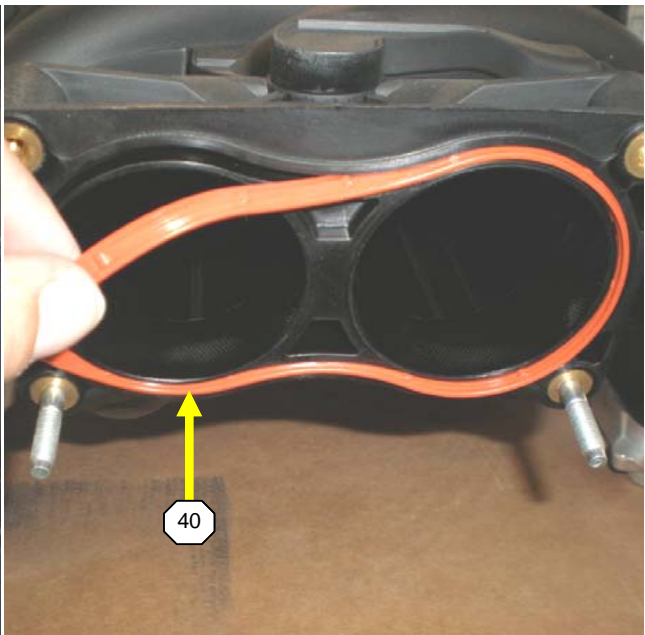
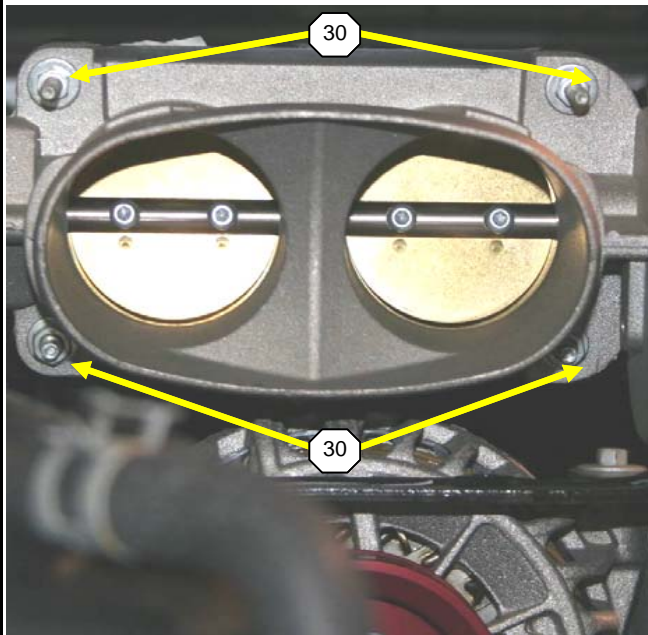
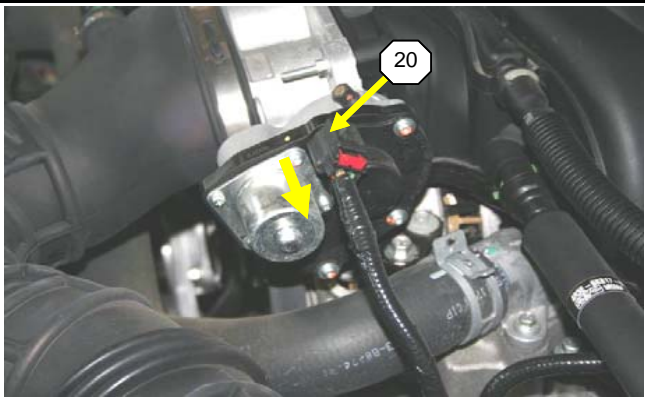
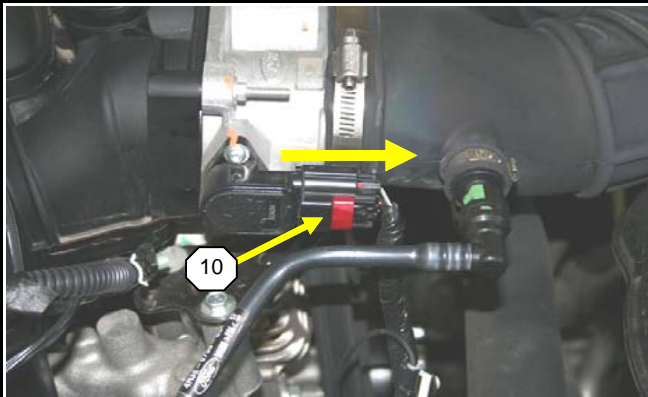

10

Disconnect the throttle position sensor electrical connector by sliding the red shield on the connector towards the front of the car. Push down on the now exposed tab, and pull the connector towards the front of the vehicle to remove.

20

Disconnect the electronic throttle control electrical connector by pulling the red locking tab outward. Pull the connector outward.

30

Remove the 2 studded bolts at the top of the throttle body and remove the 2 nuts at the bottom. Remove the throttle body.

40

Once the throttle body is removed, remove the orange gasket from the intake manifold. Both the gasket and throttle body will be re-used.

ITEM	PART NUMBER	QTY.	DESCRIPTION

NOTES:

TORQUE



PROCESS PAGE

REMOVE THROTTLE BODY

TORQUE

ITEM

OPERATION

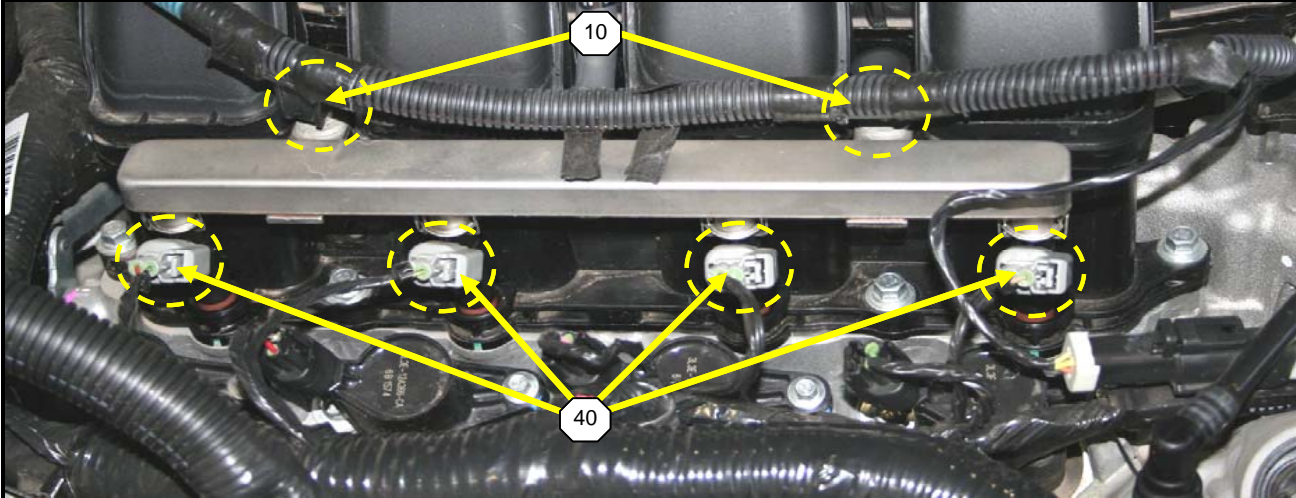

NOTICE: No smoking, flames, or sparks around the fuel system. The fuel line and fuel rail can give off fumes that are flammable and may ignite if there is any form of spark or open flame near it.

10

Detach the two wiring harness retainers from the fuel rail mounting stud bolts and position the harness to the side.

20

Disconnect the retainer holding the vacuum hose to the fuel rail mounting stud.

30

Disconnect the fuel rail temperature and pressure sensor electrical connector and the vacuum hose from the fuel rail.

40

Disconnect the 8 fuel injector electrical connectors (grey) from the fuel injectors.

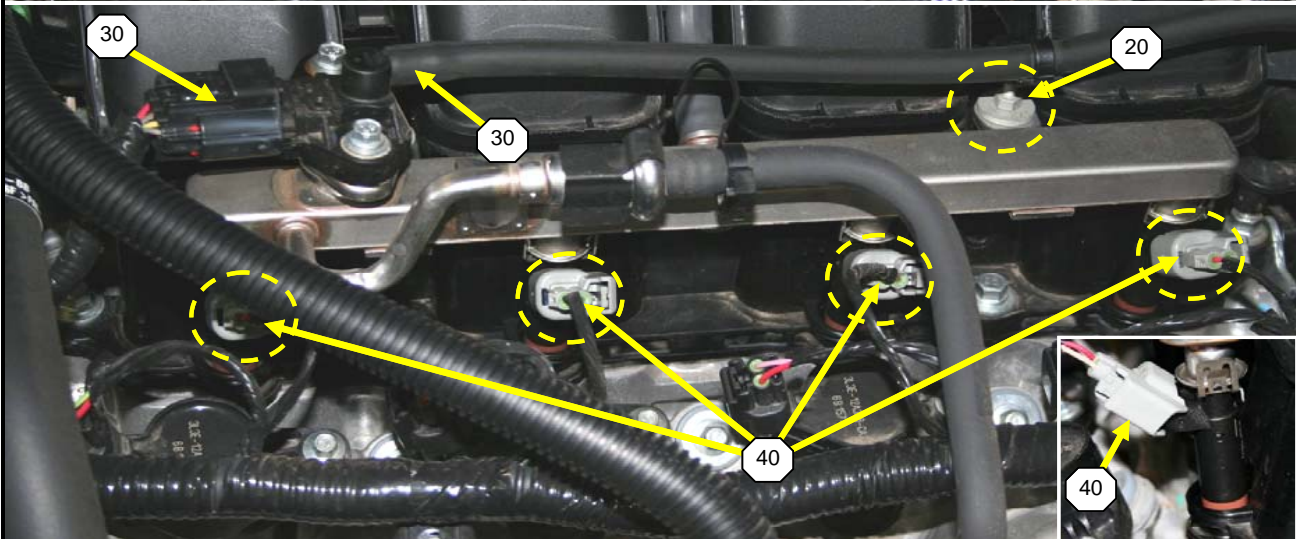

ITEM	PART NUMBER	QTY.	DESCRIPTION

NOTES:

TORQUE



PROCESS PAGE

REMOVE FUEL RAIL

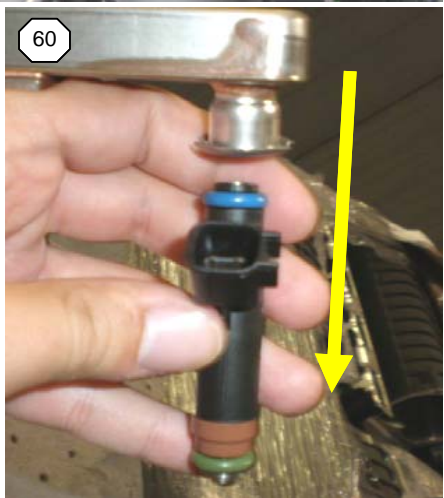
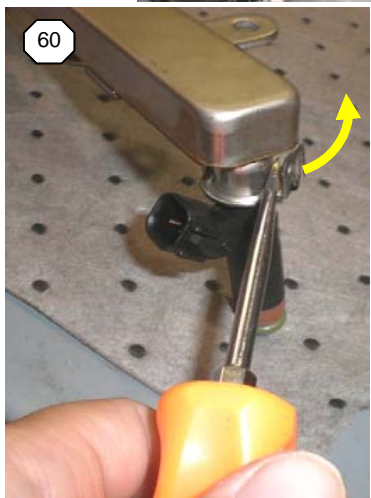
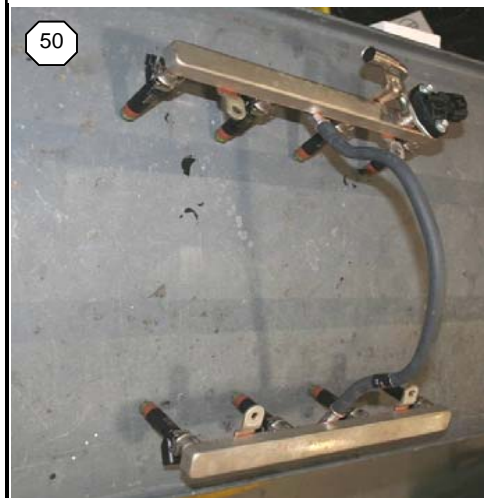
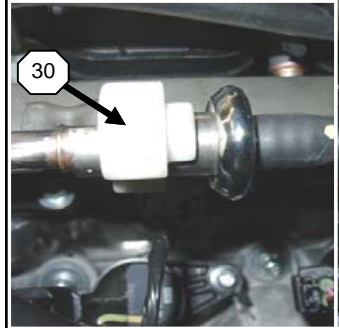
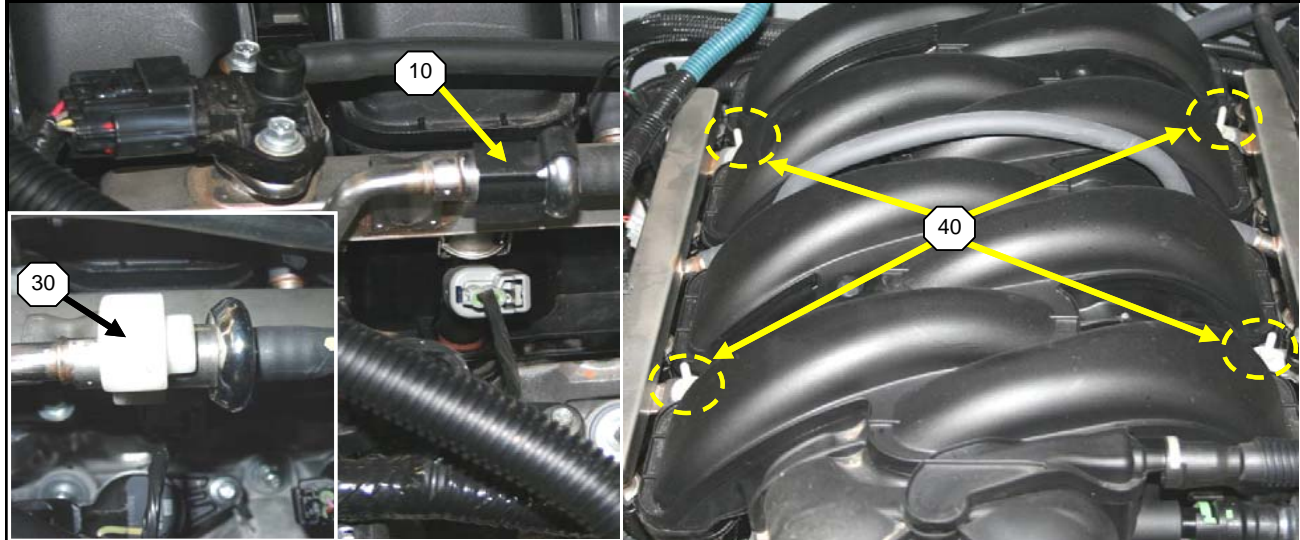

- NOTICE:** No smoking, flames, or sparks around the fuel system. The fuel line and fuel rail can give off fumes that are flammable and may ignite if there is any form of spark or open flame near it.
- 10 Remove the safety clip from the fuel line connector on the fuel rail.
 - 20 Place a rag over the fuel line connection to protect against escaping fuel and vapors.
 - 30 Place the fuel line disconnect tool on the fuel rail side of the fuel rail. Slide the fuel line disconnect tool towards the rear of the vehicle until the tool locks in place. Disconnect the fuel line.
 - 40 Remove the 8mm fuel rail stud bolts and save two of them (they will be used later).
 - 50 Lift the fuel rail assembly with injectors out of the vehicle.
 - 60 Remove each fuel injector (8 total) with a flat blade screwdriver. Set the tip of the screwdriver between the flange in the fuel rail (where the fuel injector connects), and one of the ears of the injector retaining clip. Use the screwdriver to disengage the tab on the clip ear, and pry away from the injector connector. Once the clips are removed, pull each injector out of the fuel rail.
- NOTICE:** The injector clips have tension on them. When removing them with a screwdriver, they may want to pop off the injector and go flying. Try to contain the clips when removing and make sure to wear safety glasses. Save the 8 injector clips, they will be re-used.

NOTES:

TORQUE	SALEEN SPEEDOLAB	
	PROCESS	PAGE
	REMOVE FUEL RAIL	
		14

TORQUE

ITEM

OPERATION

REAR OF INTAKE MANIFOLD SHOWN

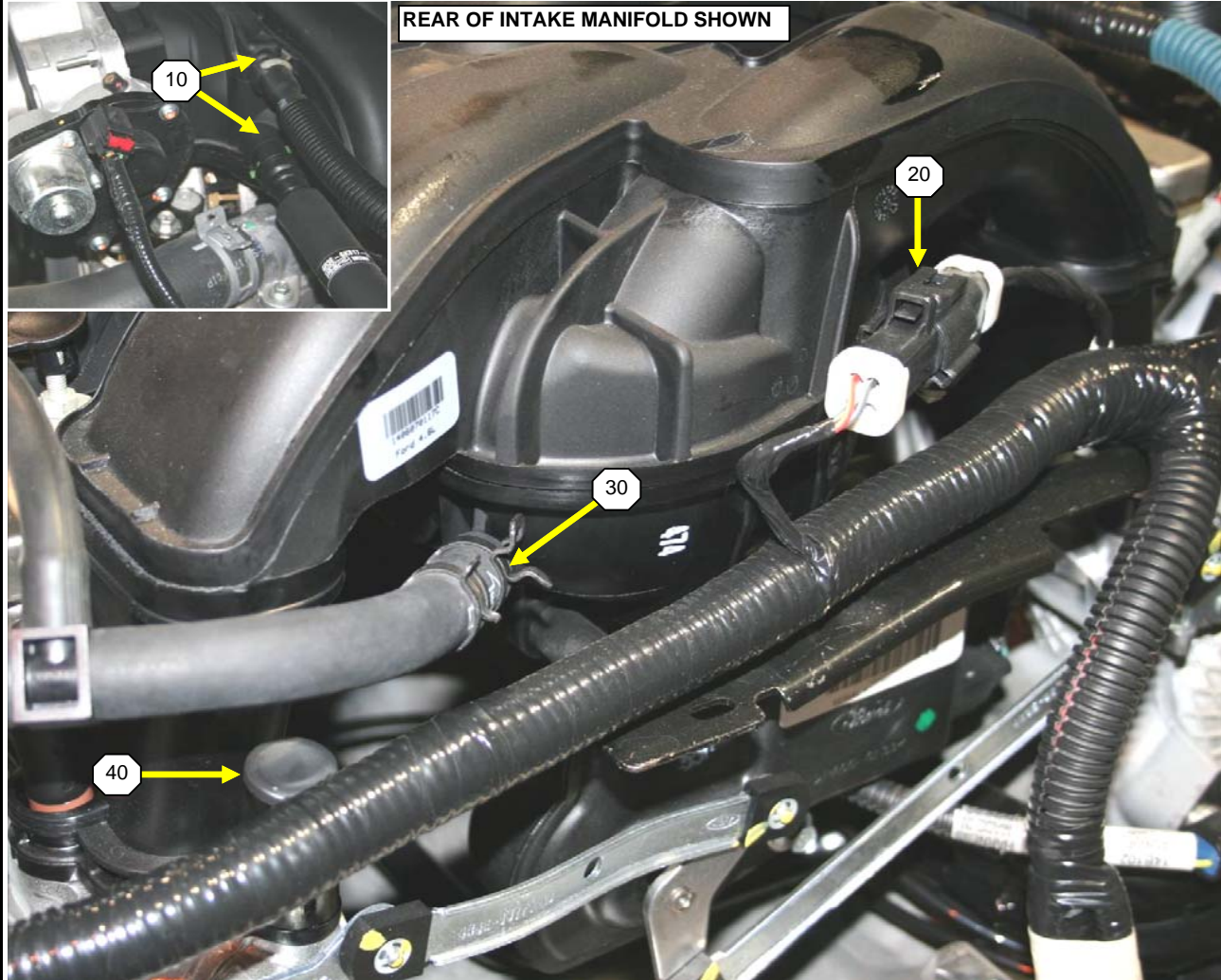

- 10 Disconnect the evaporative emissions tube and the crankcase ventilation tube from the front driver's side of the intake manifold.
- 20 Disconnect the charge motion control valve electrical connector located at the rear of the intake manifold.
- 30 Using hose clamp pliers, disconnect the vacuum hose that runs from the rear driver's side of the intake manifold to the T-fitting (the 3/8" hose on the other side of the T-fitting runs to the vacuum brake booster).
- 40 Disconnect the retainer holding the main engine wire harness to the rear driver's side intake manifold stud bolt.

ITEM	PART NUMBER	QTY.	DESCRIPTION

NOTES:

TORQUE		
		PROCESS
		REMOVE INTAKE MANIFOLD
		PAGE
		15

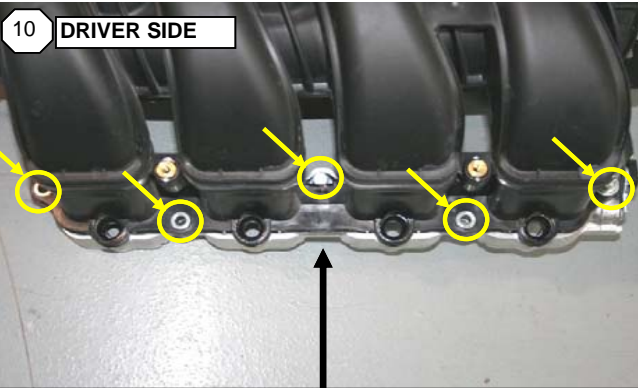
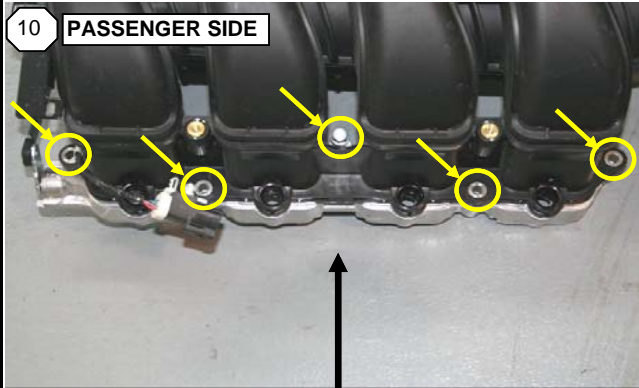

REMOVE 5 BOLTS RETAINING THE INTAKE MANIFOLD TO THE PASSENGER (RH) CYLINDER HEAD. THE CENTER BOLT IS LOCATED TO THE INSIDE OF THE INTAKE RUNNERS.

REMOVE 5 BOLTS RETAINING THE INTAKE MANIFOLD TO THE DRIVER (LH) CYLINDER HEAD. THE CENTER BOLT IS LOCATED TO THE INSIDE OF THE INTAKE RUNNERS.

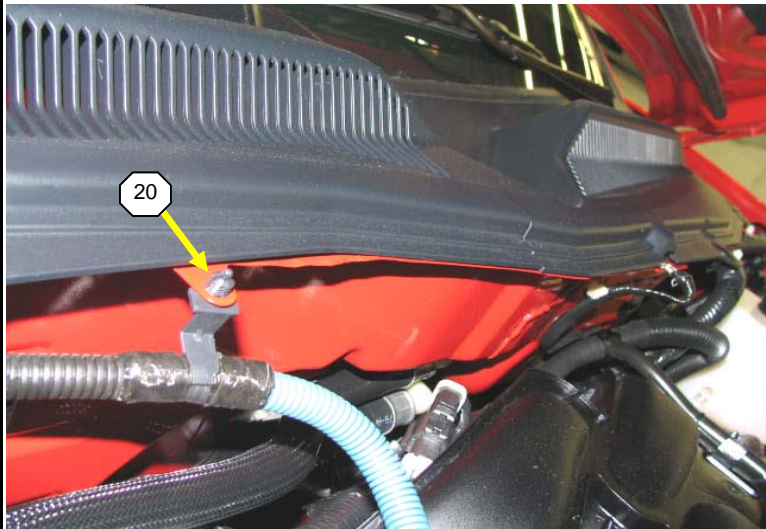

- 10 Remove the ten 10mm bolts (5 per side) to loosen the intake manifold from the cylinder heads.
 - 20 Remove the tree clip (on the alternator power wire) from the passenger side fire wall to allow the manifold more room for removal.
 - 30 Remove the intake manifold.
 - 40 Remove the 8 intake manifold gaskets (4 per side), they will be used with the new supercharger assembly.
- NOTICE:** If the engine is a high mileage engine, it is recommended that new intake manifold gaskets be used.
- C NOTICE:** 2009 model year vehicles have different intake manifold gaskets than the 2005 to 2008. The intake manifold gaskets for the 2009 model are 1 piece for each side of the manifold (2 total), 2005 to 2008 gaskets are 1 individual ring for each runner (8 total). If your vehicle is a 2009, the gaskets will not be re-used.

NOTES:

ITEM	PART NUMBER	QTY.	DESCRIPTION

TORQUE			PAGE
PROCESS			
REMOVE INTAKE MANIFOLD			
		16	

TORQUE

ITEM

OPERATION



- 10 With a tree puller, remove the alternator power wire from the top alternator bracket.
- 20 Disconnect the alternator power wire from the main engine harness. They are connected on the passenger side of the motor.
- 30 Remove the alternator power wire from the positive battery cable clamp. It is fastened to the clamp with one 10mm nut.

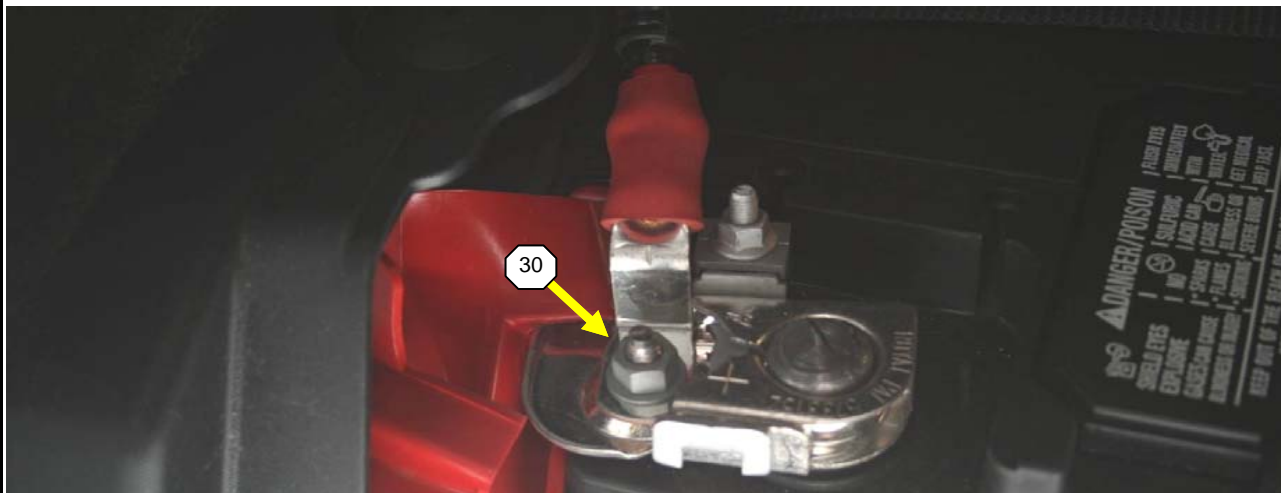

ITEM	PART NUMBER	QTY.	DESCRIPTION

NOTES:

TORQUE



PROCESS PAGE

REMOVE ALTERNATOR WITH HARNESS



TORQUE



ITEM



OPERATION

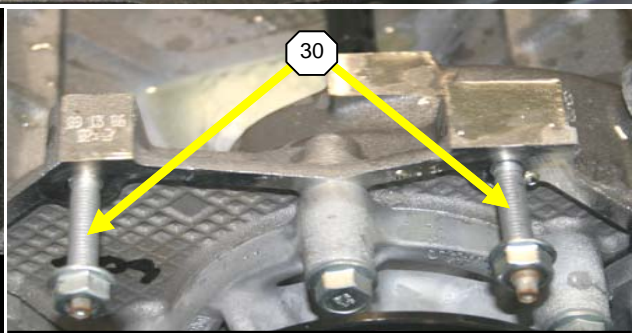
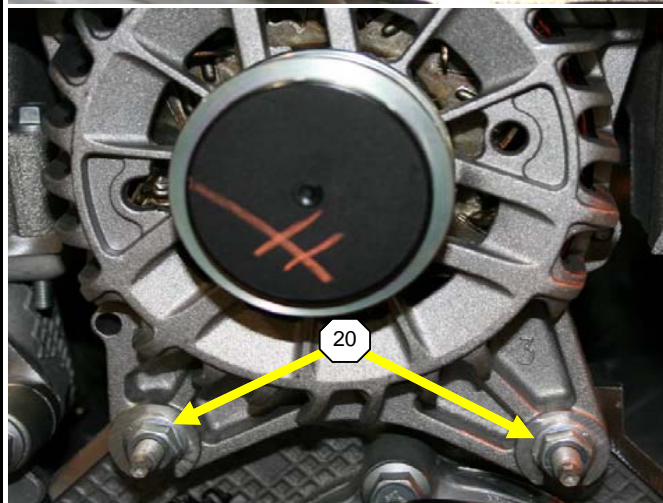
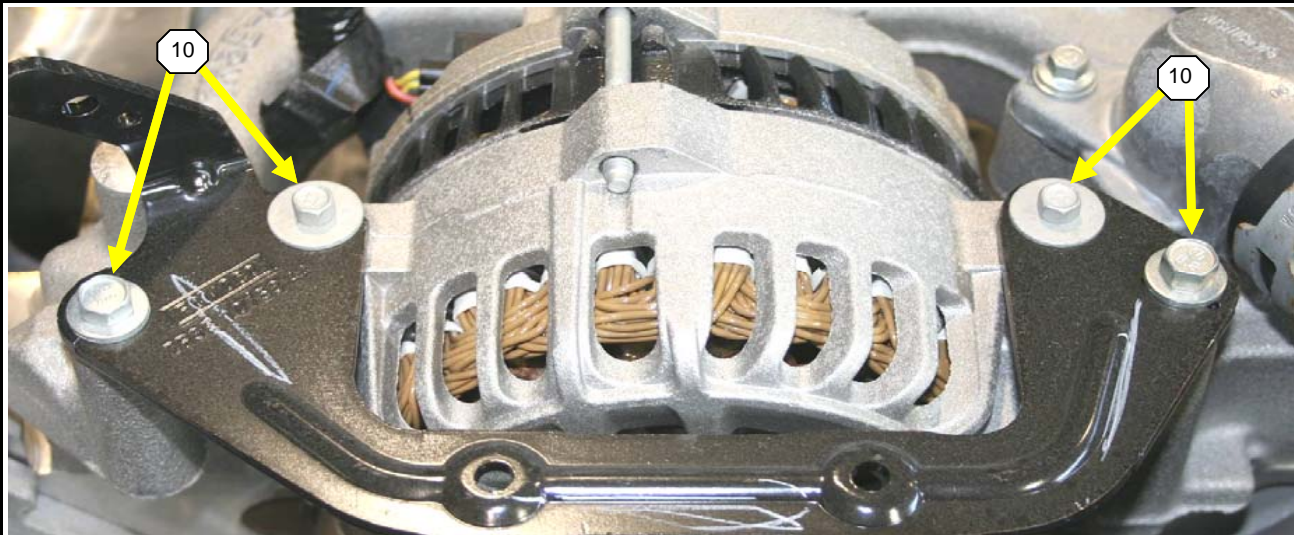

REMOVE THE 2 STUDS FROM THE ENGINE BLOCK

10

Remove the top alternator bracket by removing the 4 bolts (two 8mm bolts and two 10mm bolts). Save the two 8mm bolts, they will be re-used later.

20

Remove the two 13mm nuts (1 per side) holding the bottom of the alternator to the engine. Then lift the alternator with the attached power wire off of the 2 studs.

30

Remove the 2 studs from the engine block with a 6-point, 5mm socket.

NOTICE: 2009 model vehicles have a different alternator than the one pictured (2005 to 2008). Both alternators remove the same way.

ITEM	PART NUMBER	QTY.	DESCRIPTION

NOTES:

TORQUE



PROCESS PAGE

REMOVE ALTERNATOR WITH HARNESS



TORQUE



ITEM



OPERATION



10

Use tension clamp pliers to release the tension clamp securing the driver (LH) side upper radiator hose to the water cross over. Once the clamp is released, pull the LH upper radiator hose off of the water crossover.

20

Use tension clamp pliers to release the tension clamp securing the passenger (RH) side upper radiator hose to the water cross over. Once the clamp is released, pull the RH upper radiator hose off of the water crossover.

30

Tuck the disconnected passenger side hose off to the side. Keep the clamps on the hose, it will be used for the new water crossover.

ITEM	PART NUMBER	QTY.	DESCRIPTION

NOTES:

TORQUE



PROCESS

PAGE

DISCONNECT UPPER RADIATOR HOSES
2005- 2006 VEHICLES

A

TORQUE

ITEM

OPERATION

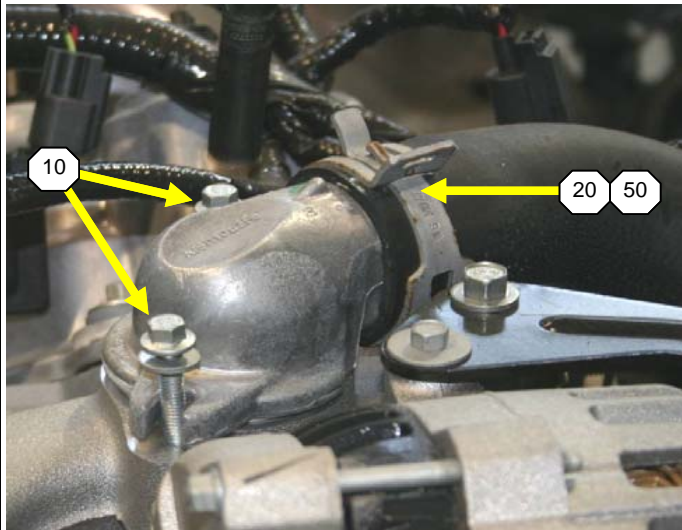

- 10 Remove the two 8mm bolts holding the thermostat cover onto the water crossover.
- 20 Release the clamp and remove the upper rad hose from the thermostat cover.
- 30 Remove the thermostat with the rubber o-ring from the water crossover.
NOTICE: Save both the thermostat and the o-ring for re-installation into the new crossover in a later step.
- 40 Release the tension clamp securing the upper radiator hose to the radiator. Pull the radiator hose off of the radiator and remove.
- 50 Once the upper radiator hose is removed from the vehicle, remove the 2 tension clamps from the hose. Save the clamps, they will be re-used later.

ITEM	PART NUMBER	QTY.	DESCRIPTION

NOTES:

TORQUE



PROCESS

REMOVE UPPER RADIATOR HOSE
2007- 2009 VEHICLES

PAGE

B

C

TORQUE

ITEM

OPERATION

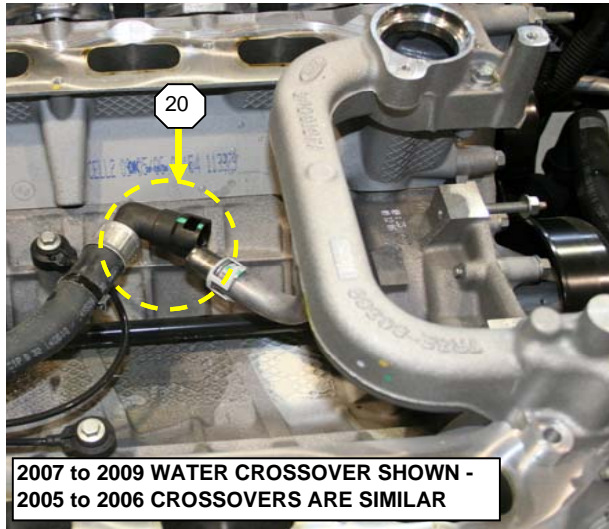
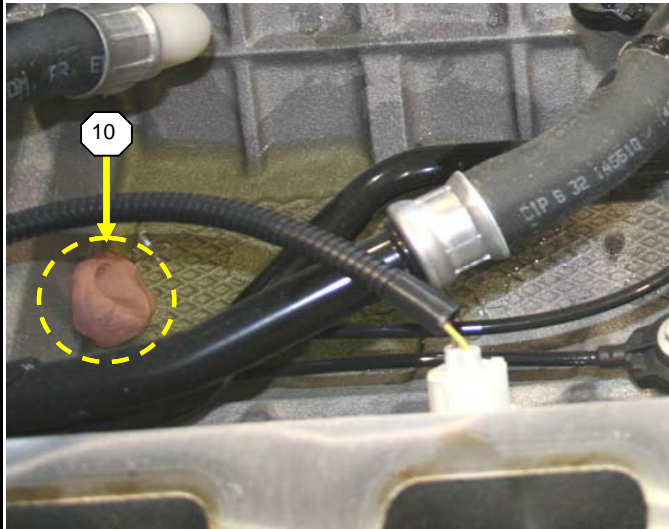

2007 to 2009 WATER CROSSOVER SHOWN -
2005 to 2006 CROSSOVERS ARE SIMILAR

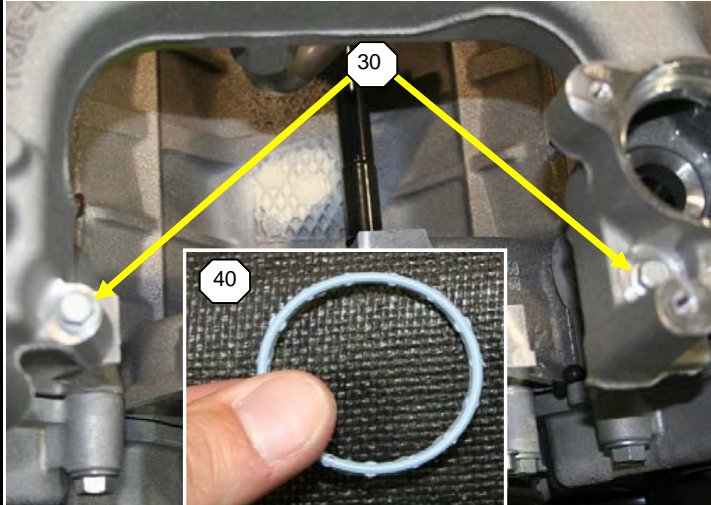

- 10 Before removing the water crossover, plug the weep hole at the back of the engine block. This will contain the coolant on the top of the block for easier clean up and less mess.
- 20 Disengage the locking clip on the heater return and supply hose and disconnect the hose from the back of the water crossover.
- 30 Remove the two remaining 10mm bolts retaining the water crossover to the engine (the other two bolts were shared with the intake manifold). Remove the water crossover.
- 40 Save the round blue gasket found on the underside of the water crossover. It will be used on the new crossover.
NOTICE: For 2007 to 2009 vehicles, see below.
- 50 After the water crossover is removed, cover the exposed head ports with masking tape.



NOTICE: If your vehicle is a 2007 to 2009, you will also need to save the other water crossover gasket (pictured next to this notice).

ITEM	PART NUMBER	QTY.	DESCRIPTION

NOTES:

TORQUE



PROCESS PAGE

REMOVE WATER CROSSOVER

TORQUE

ITEM

OPERATION

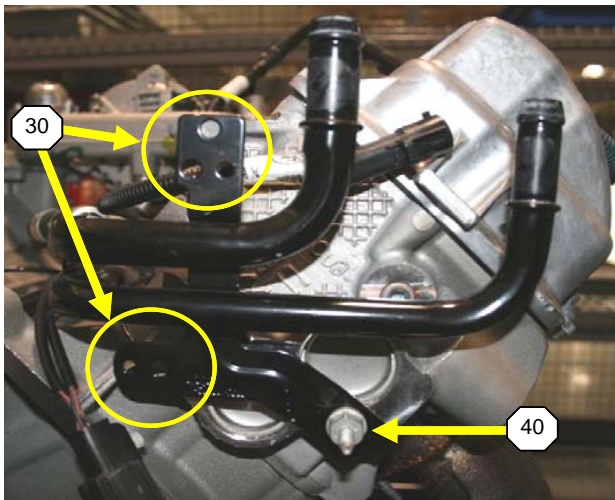
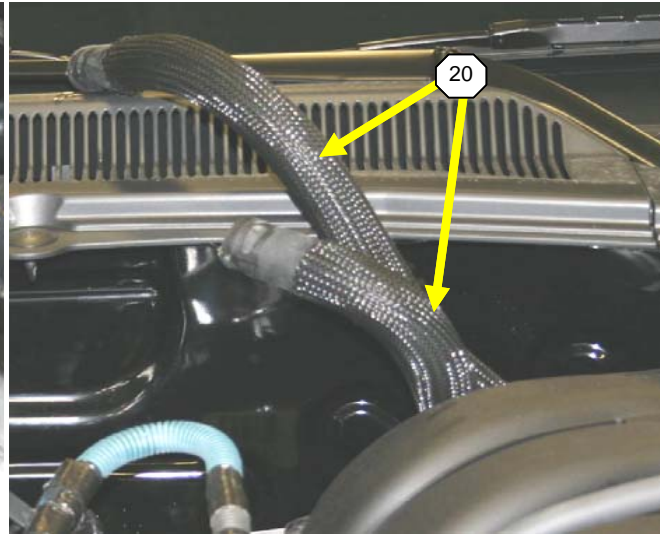
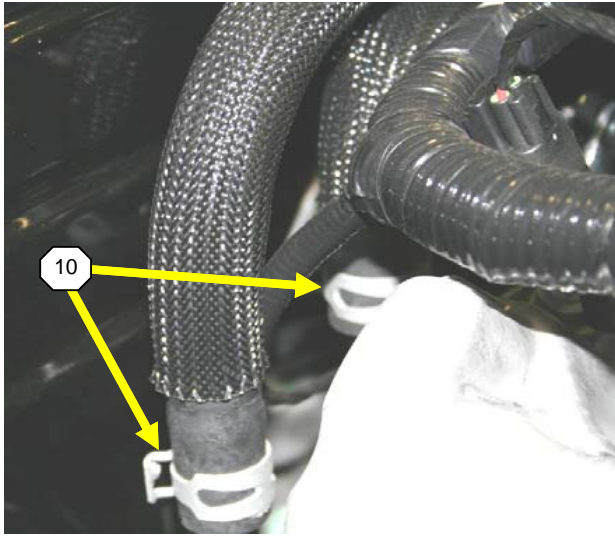

- 10 Locate the heater hoses behind the passenger (RH) side valve cover, and use a hose clamp tool to remove them. The hoses may be glued onto the water tube, so heat may be needed to break down the glue. If heat is used, make sure that the wires are out of the way to prevent damage.
- 20 Set the heater hoses out of the way so the harnesses and water tube stud bolt can be accessed.
- 30 Remove the 2 engine harness connectors from the back of the water tube assembly if they are still attached.
- 40 Remove the 13mm stud bolt holding the water tube to the back of the passenger (RH) side head.
- 50 Pull the water tube rearward to slide the water tube off of the coolant fitting in the engine block. Remove the water tube.

ITEM	PART NUMBER	QTY.	DESCRIPTION

NOTES:

TORQUE



PROCESS PAGE

REMOVE WATER TUBE

TORQUE

ITEM

OPERATION

REMOVE THESE PULLEYS IF EQUIPPED

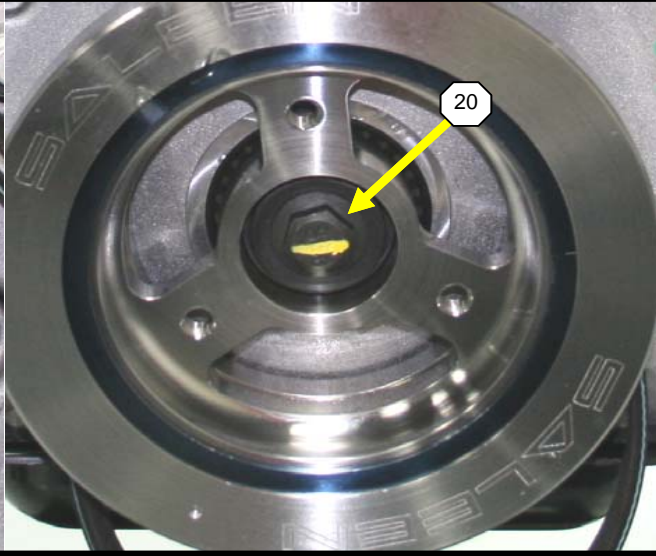
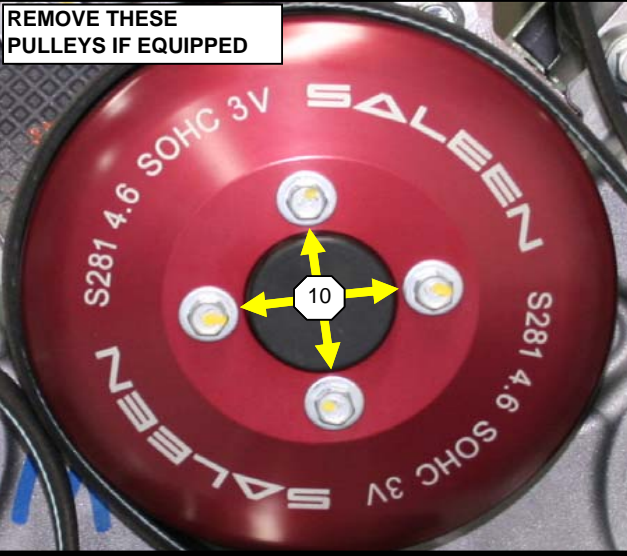

REPLACE WITH STOCK PULLEYS

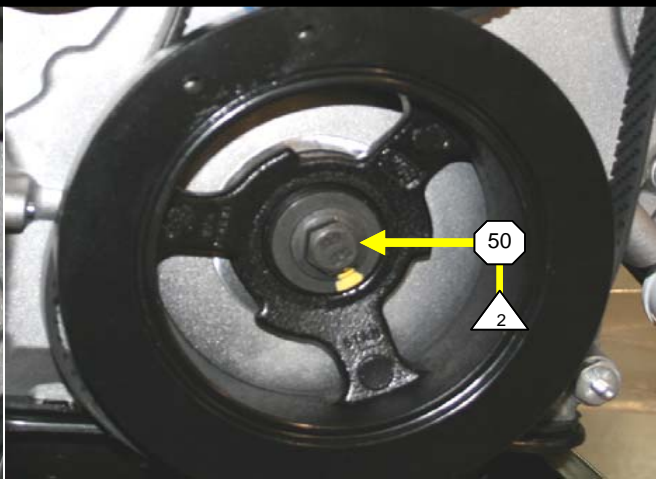
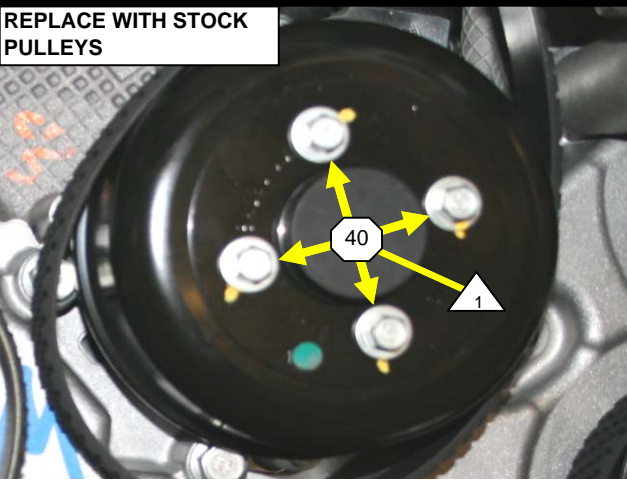

NOTICE: If your vehicle is a S281 3-Valve, H281 3-Valve, or any other vehicle that has this pulley system (shown at the top left), these pulleys need to be removed and returned to stock. The same goes for any other aftermarket pulley system your vehicle may have. The Saleen Series VI.5 Supercharger System only works with the stock pulley system.

10 Remove the water pump pulley by removing the four 10mm bolts. Once the bolts are removed, the pulley will slide right off the water pump.

20 Remove the crankshaft damper pulley by holding the damper from moving, and then with a breaker bar or impact, remove the one 18mm center bolt.

30 Using a crank pulley puller, remove the crank pulley from the engine.

40 Obtain the Ford water pump pulley (XL3E-8A528-AA) and set it onto the water pump. Retrieve the four 10mm bolts removed from **OPERATION 10** and apply blue Loctite to the threads. Re-install the 4 bolts. With a torque wrench, tighten each bolt to **18 Lb-ft +/- 2.7 Lb-ft**.

50 Install the Ford crank damper pulley (6316) by sliding it onto the end of the cranks shaft (line up the crank key with the crankshaft keyway). Apply a dab of sealant to the keyway, and install 1 new 18mm torque-to-yield bolt (FR5Z-6A340-B) and tighten with a torque wrench using the following process....

The torque sequence is as follows...

1. 66 +/- 9.9 Lb-ft
2. Loosen 360°
3. 37 +/- 5.5 Lb-ft
4. + 90° Rotation

NOTES:

TORQUE

1 18 +/- 2.7 Lb-ft

- 2 1. 66 +/- 9.9Lb-ft
2. Loosen 360°
3. 37 +/- 5.5Lb-ft
4. + 90°



PROCESS
REPLACE SALEEN 3-VALVE PULLEYS WITH STOCK PULLEYS

VEHICLES EQUIPPED WITH UNDERDRIVE PULLEYS

PAGE

D
22

TORQUE

ITEM

OPERATION

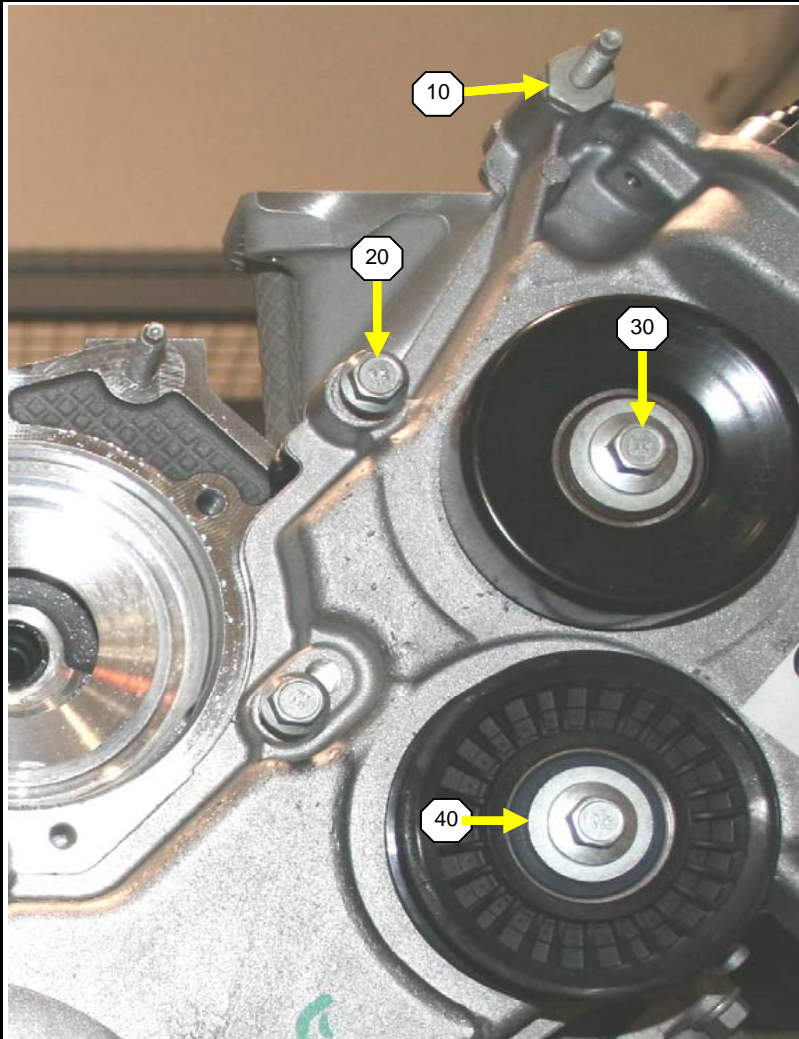

2007 to 2009 MODELS

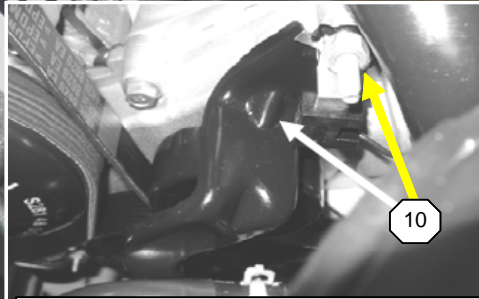
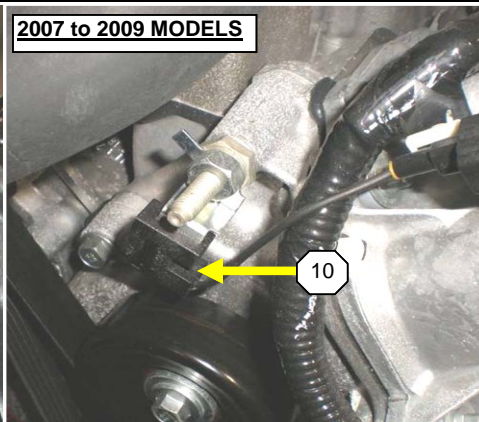

2005 to 2006 MODELS: REMOVE THE WATER HOSE UPPER SUPPORT BRACKET

10

Remove the 15mm nut holding the driver side ignition interference capacitor. Slide the capacitor off of the stud and let it hang. Remove the 18mm hex stud from the front engine cover.

NOTICE: The 2005 & 2006 Model Vehicles will have a water hose support brackets behind the ignition interference capacitor. This will need to be removed with the items above as well.

20

Remove the front engine cover 13mm bolt located just inboard of the driver side upper idler pulley.

30

Remove the top Idler pulley (mounted on the driver side of the motor) by removing the 13mm center bolt.

40

Remove the bottom Idler pulley (mounted on the driver side of the motor) by removing the 13mm center bolt.

NOTICE: Save the pulley bolt and washer. It will be re-used.

ITEM	PART NUMBER	QTY.	DESCRIPTION

NOTES:

TORQUE



PROCESS PAGE

REMOVE ACCESSORY DRIVE PULLEYS & FASTENERS

TORQUE

ITEM

OPERATION

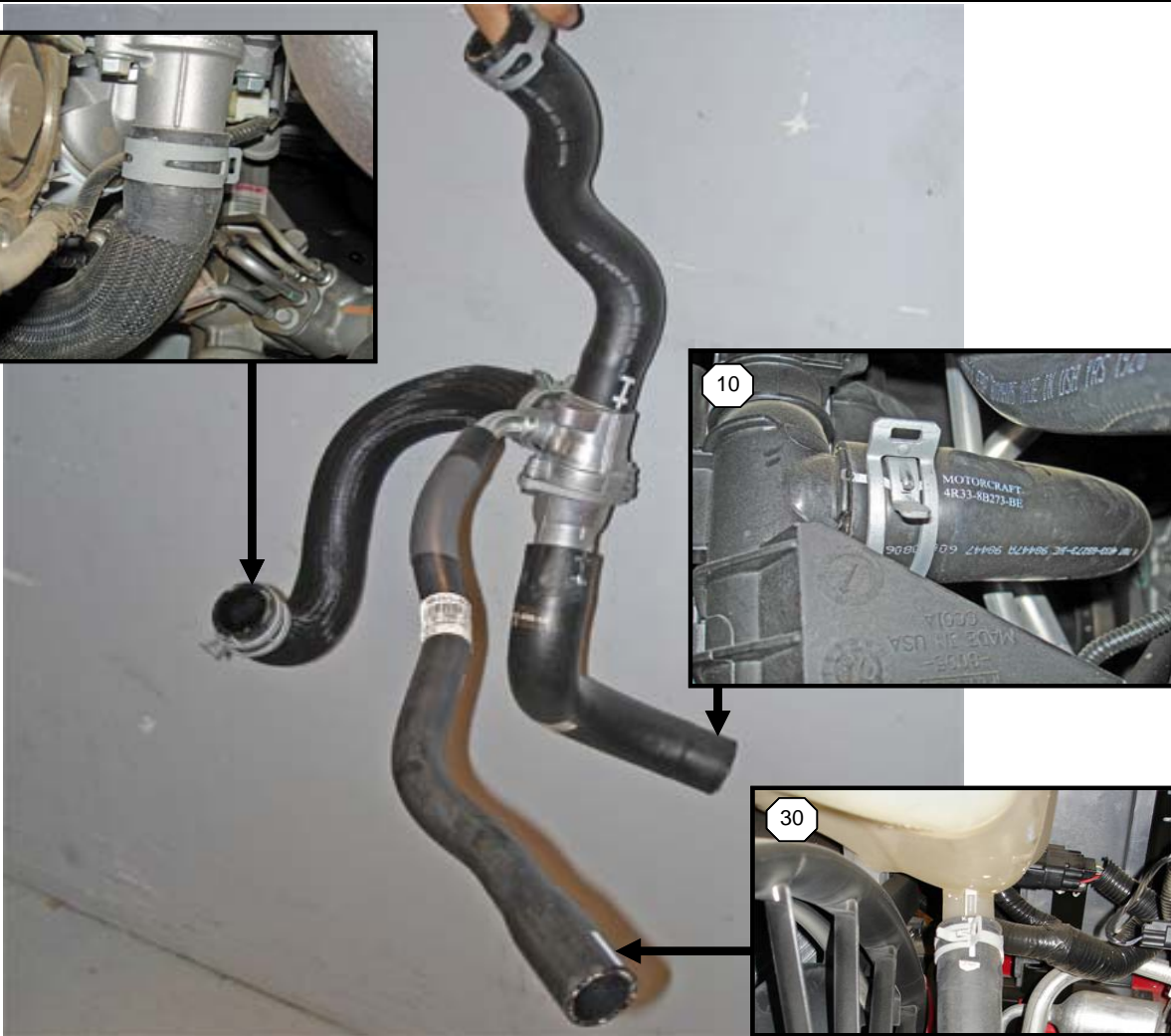

- 10 Using tension clamp pliers to compress the tension clamp, remove the lower thermostat outlet hose from the lower radiator inlet.
- 20 Remove the large thermostat side inlet hose from the engine block outlet.
- 30 Remove the small thermostat side inlet hose from the lower outlet of the coolant reservoir.
- 40 Remove coolant hose assembly.

NOTICE: Remove all of the tension clamps from the end of each hose. These clamps will be re-used in a later process. Some clamps might be glued to the hose. The glue can be softened with heat.

ITEM	PART NUMBER	QTY.	DESCRIPTION

NOTES:

TORQUE			PAGE
		PROCESS	
		REMOVE COOLANT HOSE ASSEMBLY	
		2005 - 2006 VEHICLES	A
			24

TORQUE

ITEM

OPERATION



NOTICE: For the next few steps, the front end of the vehicle will need to be elevated off of the ground. All vehicles when being lifted should be on flat solid ground. If a jack is being used, make sure the vehicle is supported on jack stands (at least 1 at each front corner, at a solid place on the frame). Make sure the rear wheels are chocked, the parking brake is set, and the vehicle is in park or in gear. **REMEMBER**, when lifting any vehicle whether it be with a hoist, jack, etc.. follow all safety guidelines in the equipment's manual.

- 10 Break loose the 5 lug nuts on the RH front wheel with a breaker bar and a 13/16" socket.
- 20 Elevate the front of the vehicle off of the ground, so that the front tires no longer touch the ground (**READ NOTICE ABOVE**).
- 30 Remove the 5 lug nuts on the RH front wheel with a 13/16" socket. Make sure to hold the wheel, it may want to fall off the hub once all lug nuts are removed.
- 40 Remove the RH front wheel and set it aside where it will not be damaged.

ITEM	PART NUMBER	QTY.	DESCRIPTION

NOTES:

TORQUE



PROCESS PAGE

REMOVE RH FRONT WHEEL

TORQUE

ITEM

OPERATION

6 of 7 RETAINERS SHOWN

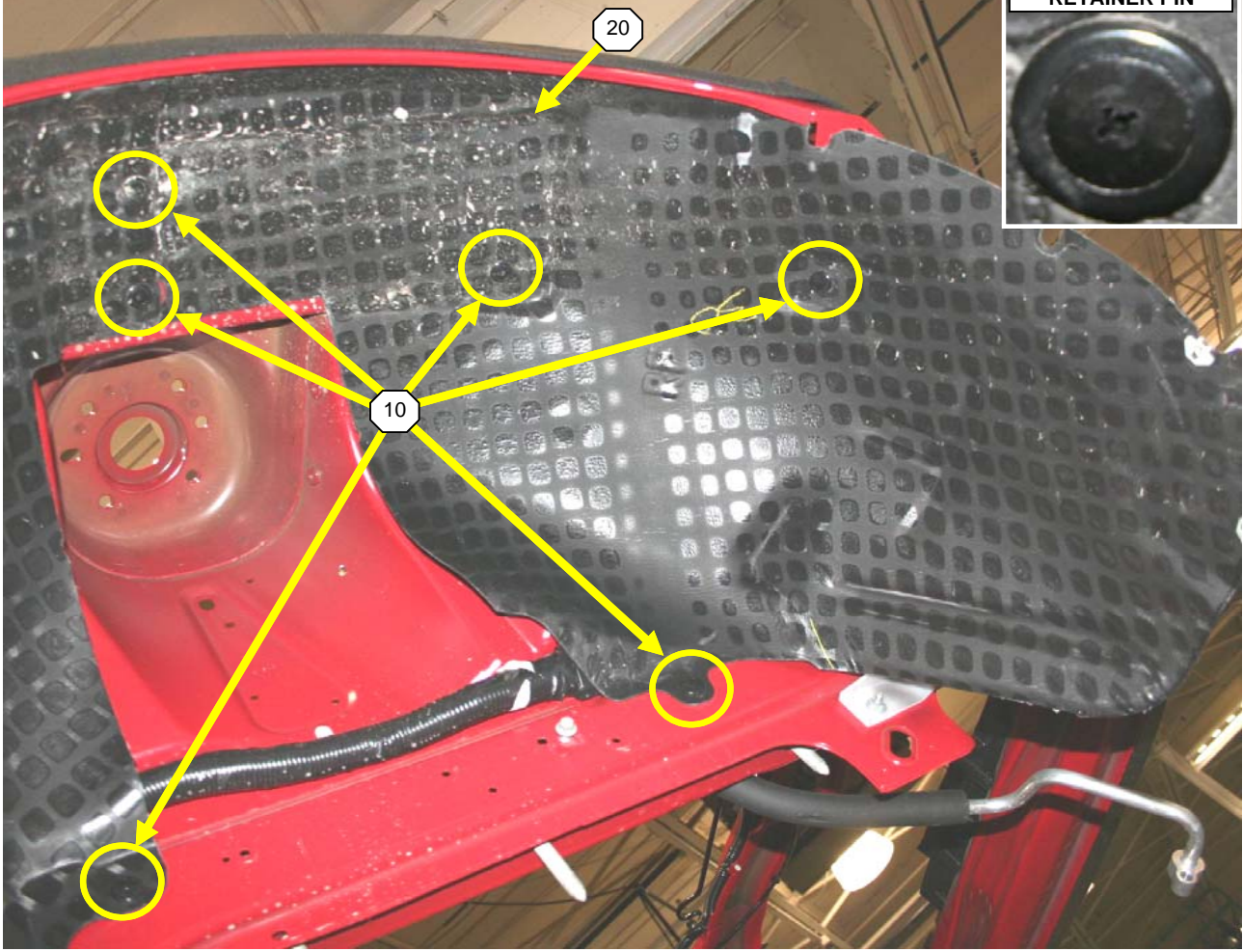

NOTE: The fender liner is made up of 2 pieces

10 With a Philips screw driver, rotate the head of each pin retainer to pop loose the head and then pull to remove. There are 7 retainer pins holding each half of the front fender liner into place.

20 Remove each front fender liner and set aside.

ITEM	PART NUMBER	QTY.	DESCRIPTION

NOTES:

TORQUE



PROCESS

REMOVE RH FRONT FENDER LINERS

PAGE

TORQUE

ITEM

OPERATION

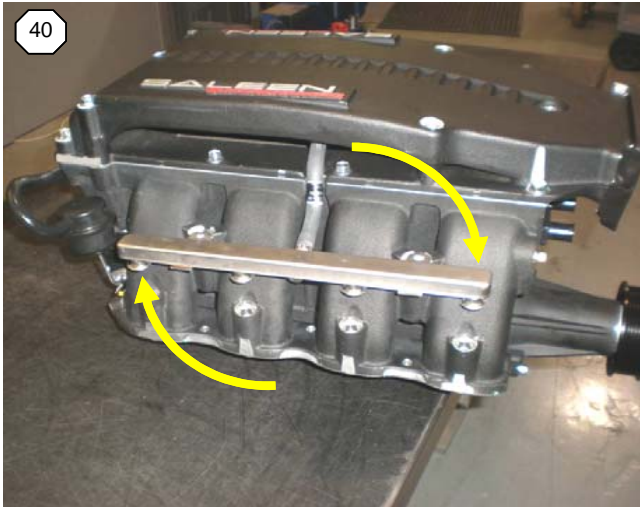
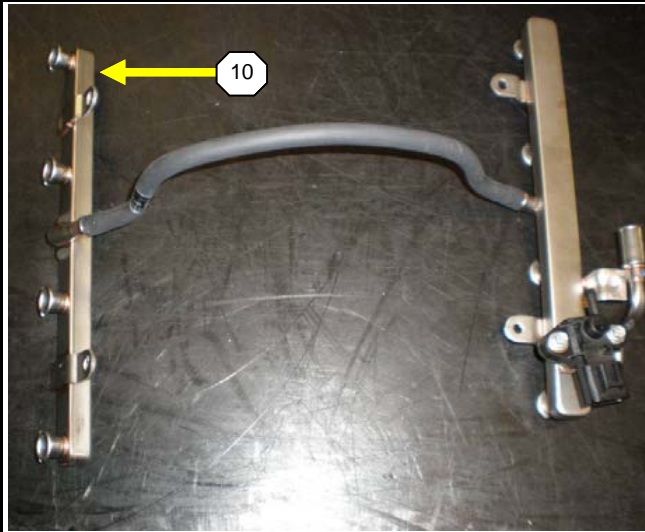

NOTICE: No smoking, flames, or sparks around the fuel system. The fuel line and fuel rail can give off fumes that are flammable and may ignite if there is any form of spark or open flame near it.

10

Retrieve the fuel rail (removed on [Page 11-1 to 11-2](#)). Rotate the passenger (RH) side fuel rail 180 degrees so that the injector ports are facing upward.

20

Retrieve the supercharger assembly. Take the upside-down portion of the fuel rail (RH rail), and insert it into the LH side of the gap in the lid.

30

Slide the RH fuel rail through the gap in the lid until it come out the RH side.

40

Once the RH fuel rail has passed through the lid, rotate it back into its previous position (fuel injector ports facing downward).

ITEM	PART NUMBER	QTY.	DESCRIPTION

NOTES:

TORQUE



PROCESS PAGE

INSTALL FUEL RAIL & INJECTORS

TORQUE

ITEM

OPERATION

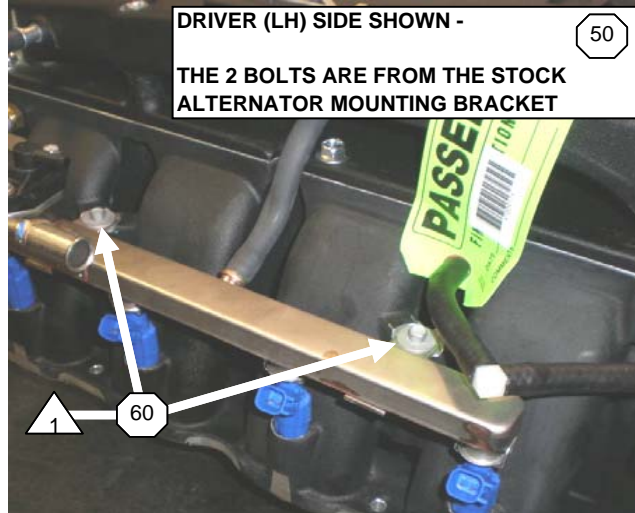
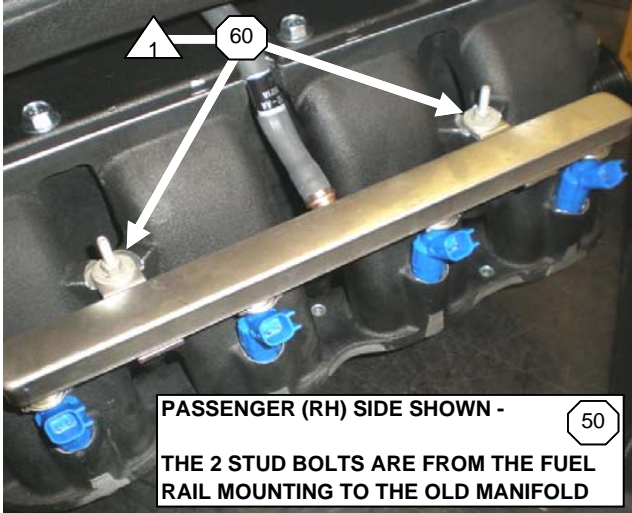
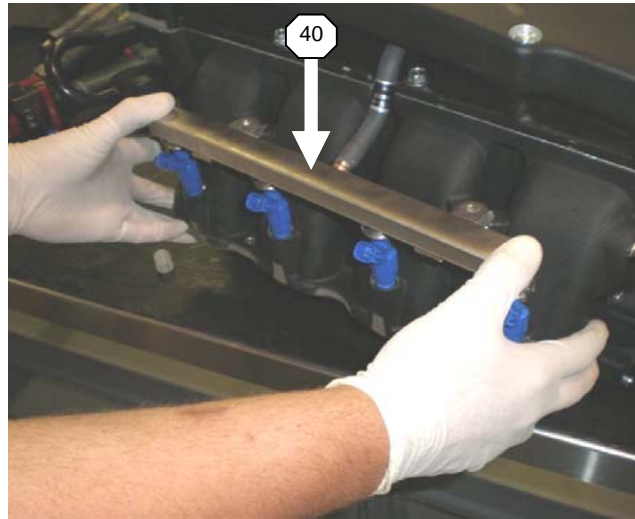
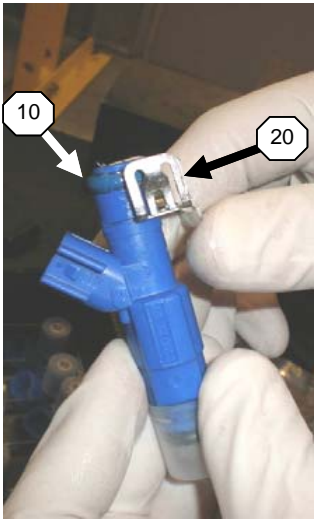

NOTICE: No smoking, flames, or sparks around the fuel system. The fuel line and fuel rail can give off fumes that are flammable and may ignite if there is any form of spark or open flame near it.

10 Retrieve the 8 fuel injector clips removed on Page 11-2, and the 8 new fuel injectors (A) from the kit. Wipe silicone lubricant onto each fuel injector o-ring (Dow Corning #111 Valve Lubricant & Sealant)

20 Install the fuel injector retainer clips onto each injector. The clip will slide into the channel on top of each injector. The 2 ears of each clip will need to face upward.

30 Once there is a clip on each injector, insert each injector into the fuel rail. Make sure the connector portion of each injector faces outboard, and that both ears of the locking clip engage the fuel rail port.

40 When all 8 injectors are installed, carefully press the injectors into the supercharger assembly. When the injectors are seated, the mounting tabs for each fuel rail will line up with the mounting holes in the supercharger assembly.

50 Fasten the fuel rail to the supercharger assembly with four 8mm bolts. Two of the bolts are the old fuel rail mounting stud bolts, they will be used to mount the passenger (RH) side fuel rail. The remaining 2 bolts are from the factory alternator mounting bracket (removed on Page 13-2). Those bolts will be used to mount the driver (LH) side fuel rail.

60 Tighten the 4 fuel rail bolts with a torque wrench to **91 Lb-in +/- 13.6 Lb-in**.

NOTICE: If the 8mm alternator mounting bolts were not saved, all four fuel rail stud bolts can be used. The alternator bolts were used for appearance purposes.

NOTES:

ITEM	PART NUMBER	QTY.	DESCRIPTION
A	00-1701-C120760	8	Fuel Injector, 2005 S281 E

TORQUE		SALEEN SPEEDLAB	PAGE
1	91 +/- 13.6 Lb-in		

TORQUE

ITEM

OPERATION

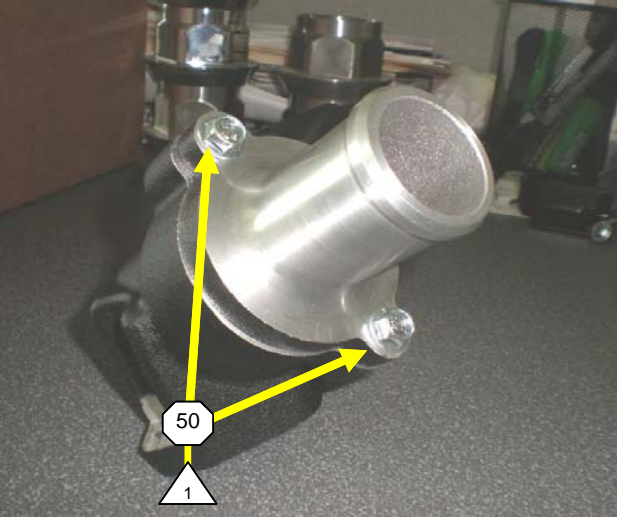
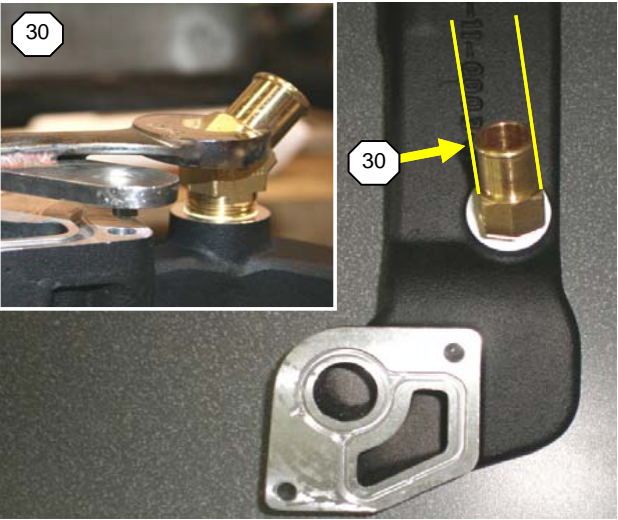
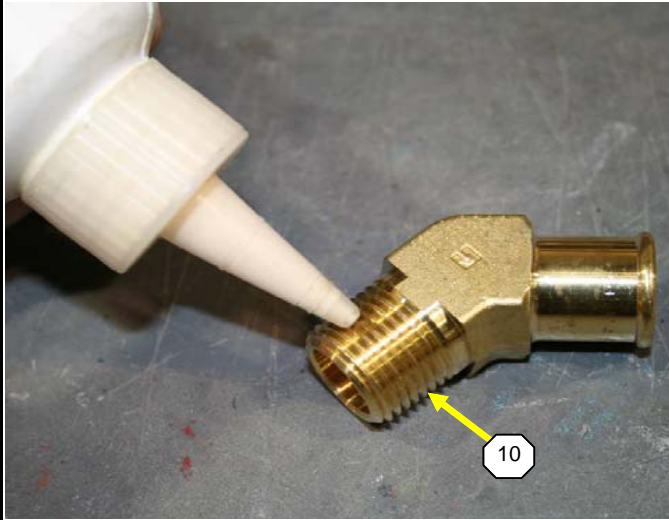

- 10 Retrieve the brass 45 degree fitting (A) and apply pipe dope to the threads.
- 20 Thread the fitting into the bottom of the water crossover (B) until it is snug.
- 30 Use a 21mm wrench to tighten the fitting. Turn the wrench until the fitting is positioned as shown.
- 40 **2005 to 2006 Models:** Retrieve the new thermostat (C) and o-ring (D), and re-install it into the water crossover. First set the thermostat into the water crossover, and then set the o-ring in place as shown.

2007 to 2009 Models: Retrieve the thermostat and o-ring (removed on Page 20), and re-install it into the water crossover. First set the thermostat into the water crossover, and then set the o-ring in place as shown.
- 50 Set the thermostat housing cover (water neck) onto the crossover (E) and line up the mounting holes (the bottom of the cover should be applying firm pressure to the o-ring to create a good seal). Install 2 bolts (F) and tighten to **91 Lb-in +/- 13.6 Lb-in**.

ITEM	PART NUMBER	QTY.	DESCRIPTION
A	00-2003-C104470	1	Brass Fitting 45 Degree, 3/4" Barb
B	00-2003-C19336	1	Water Crossover Series VI.5
C	00-2003-C19363	1	Thermostat Mustang 2007 to 2009
D	06-2003-C143810	1	O-Ring, Thermostat
E	00-2003-C19335	1	Water Neck, Water Crossover
F	00-9001-C101410	2	Capscrw Hex M6x1.0mm 25mm

NOTES:

TORQUE			PAGE
1	91 +/- 13.6 Lb-in		

TORQUE

ITEM

OPERATION

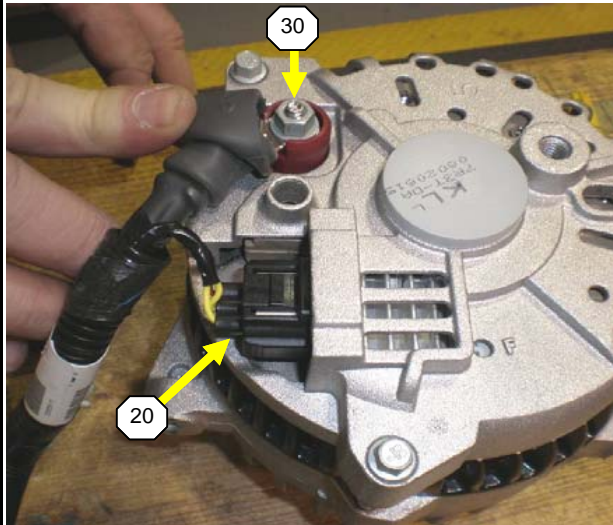

STOCK PULLEY SHOWN

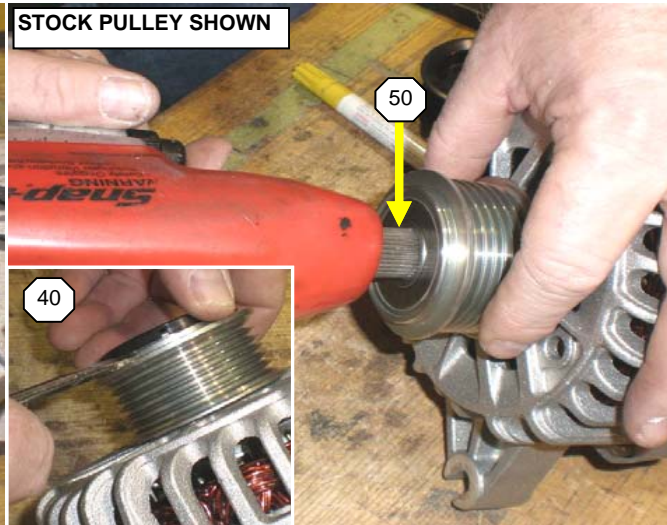

SALEEN NATURALLY ASPIRATED UNDERDRIVE PULLEY KIT PULLEY SHOWN

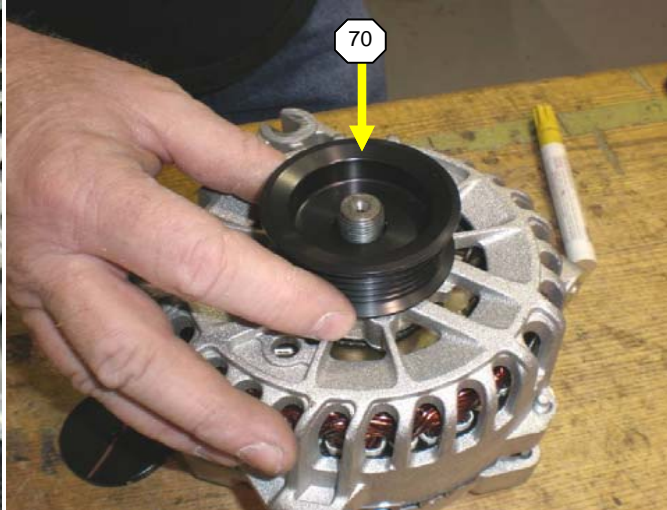

- 10 Retrieve the take-off alternator with attached alternator harness.
- 20 Disconnect the alternator harness electrical connector. There is a tab that needs to be depressed on the connector. Push in the tab and pull the connector away from the alternator.
- 30 Remove the 10mm nut holding the alternator harness ring terminal to the alternator. Remove the alternator harness.
- 40 With a flat blade screwdriver, pry the black plastic cover off of the factory alternator pulley.
- 50 Retrieve the alternator pulley tool and attach it to a 3/8" drive impact. Insert the tool into the center of the pulley and operate the impact to remove the pulley.
- 60 **Saleen Underdrive Pulley Removal:** If your vehicle has the naturally aspirated pulley kit installed (if so make sure you perform the process on **Page 22D** also), remove the alternator pulley by loosening the nut with an impact and a 24mm socket. Remove the nut, washer, and pulley.
- 70 Slip the new alternator pulley (A) over the alternator input shaft (where the original pulley was installed). Make sure the raised boss of the new pulley is facing the alternator.

ITEM	PART NUMBER	QTY.	DESCRIPTION
A	06-1604-C09936	1	Alternator Pulley S/C S197 Mustang

NOTES:

TORQUE		
		PROCESS
		REPLACE ALTERNATOR PULLEY
		2005 - 2008 VEHICLES
		A
		B
		30

TORQUE

ITEM

OPERATION

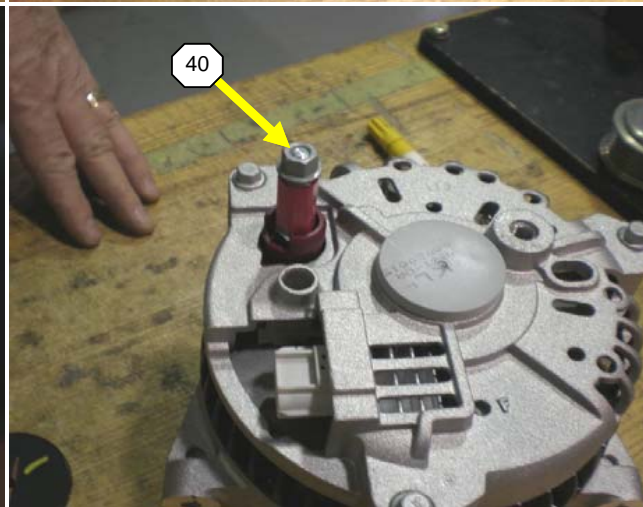
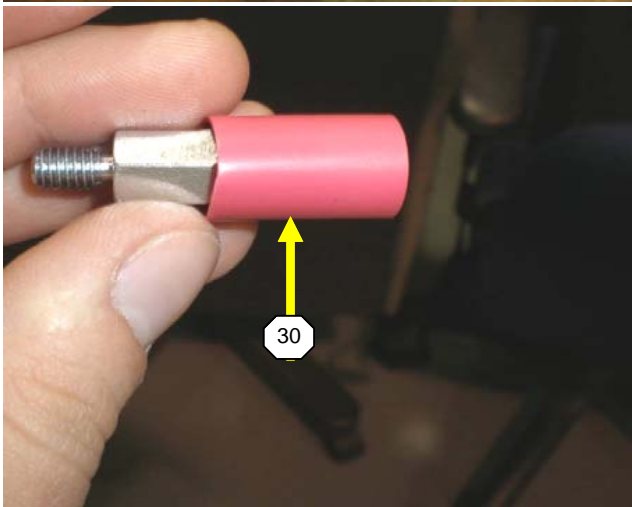
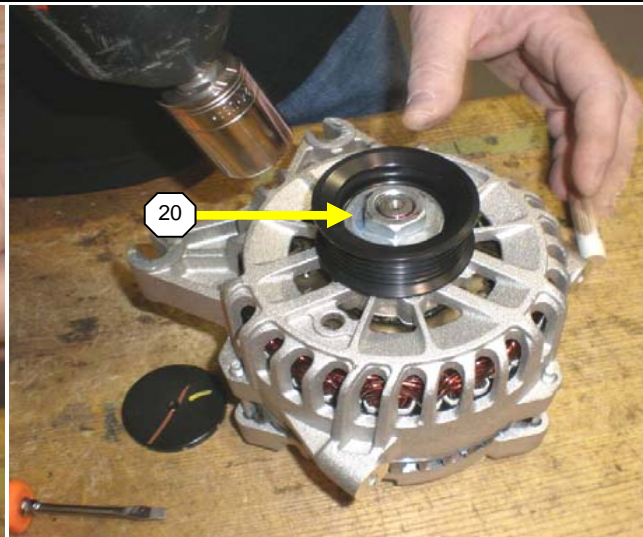

- 10 Retrieve the washer (A) and the nut (B) for the alternator. Apply a dab of red Loctite to the threads of the alternator nut.
- 20 Slide the washer over the alternator input shaft and onto the pulley. Then thread the nut onto the alternator input shaft and while holding the pulley, run the 24mm nut down with an impact.
- 30 Obtain 1 alternator stand-off (C) and a 1" section of red heat shrink (D). Slide the heat shrink over the stand-off and apply heat to form the heat shrink to the stand-off.
- 40 Thread the stand-off onto the stud on the back of the alternator (where the harness attached). Tighten the stand-off to spec, and then re-install the stock 10mm nut.

ITEM	PART NUMBER	QTY.	DESCRIPTION
A	00-9004-C111460	1	Washer 17mm ID 40mm OD
B	00-9003-C102610	1	Nut Hex Jam M16x1.5x8mm
C	00-1706-C153230	1	Standoff, Alternator Wire
D	00-1703-C070870	1"	Dual Wall Heat Shrink 1/2" Red

NOTES:

TORQUE



PROCESS

REPLACE ALTERNATOR PULLEY

2005 - 2008 VEHICLES

PAGE

A

B

31

TORQUE

ITEM

OPERATION

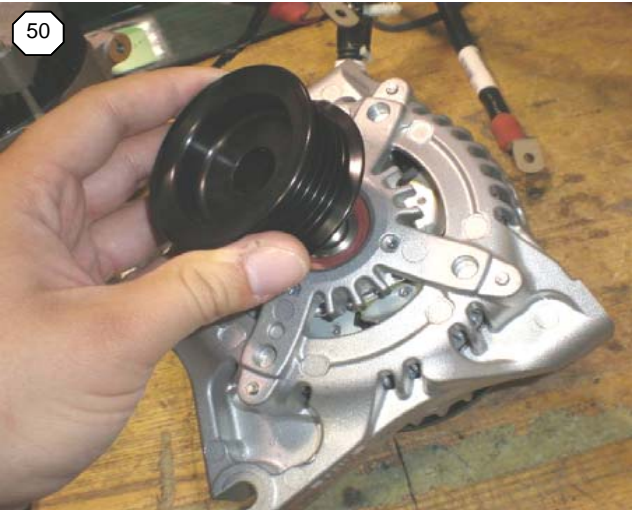
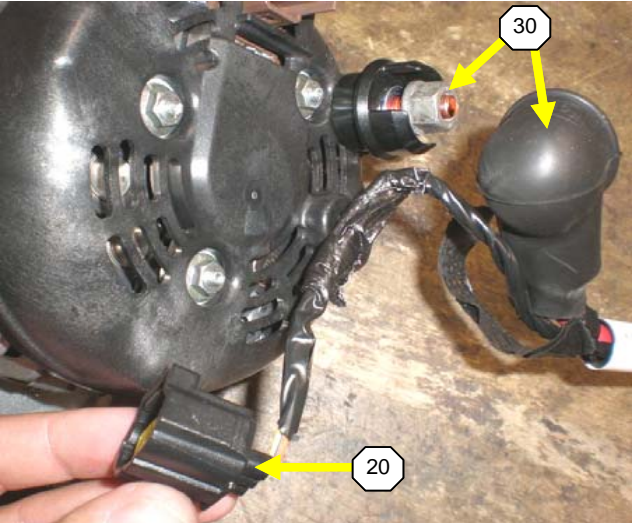
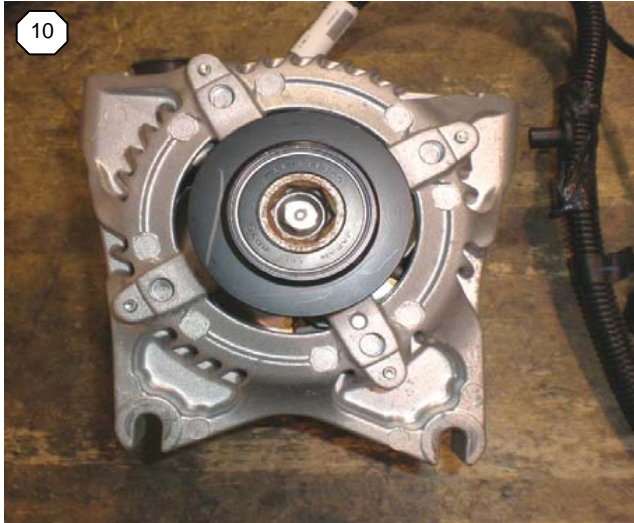

- 10 Retrieve the take-off alternator with attached alternator harness.
- 20 Disconnect the alternator harness electrical connector. There is a tab that needs to be depressed on the connector. Push in the tab and pull the connector away from the alternator.
- 30 Remove the 13mm nut holding the alternator harness ring terminal to the alternator. Remove the alternator harness.
- 40 Retrieve the Ford alternator pulley tool and attach it to an impact. Insert the tool into the center of the pulley and operate the impact to remove the pulley.
NOTICE: A pulley removal kit (not included) will be needed to remove the factory alternator pulley for 2009 vehicles.
- 50 Slip the new alternator pulley (A) over the alternator input shaft (where the original pulley was installed). Make sure the raised boss of the new pulley is facing the alternator.

ITEM	PART NUMBER	QTY.	DESCRIPTION
A	06-1602-C18921	1	Alternator Pulley S/C S197 2009

NOTES:

TORQUE		
		PROCESS
		REPLACE ALTERNATOR PULLEY
		2009 VEHICLES
		C
		30

TORQUE

ITEM

OPERATION

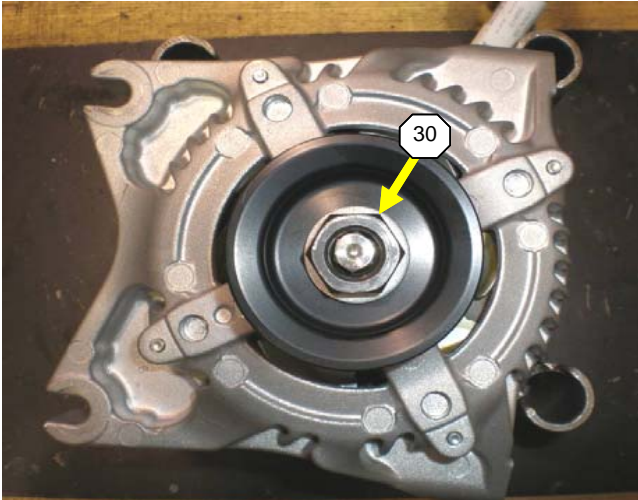
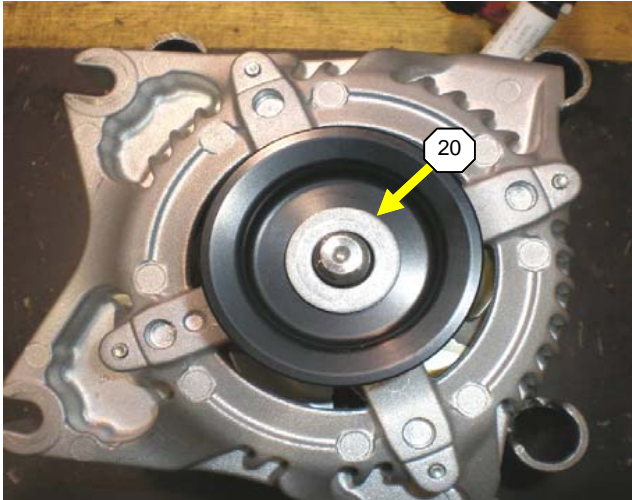
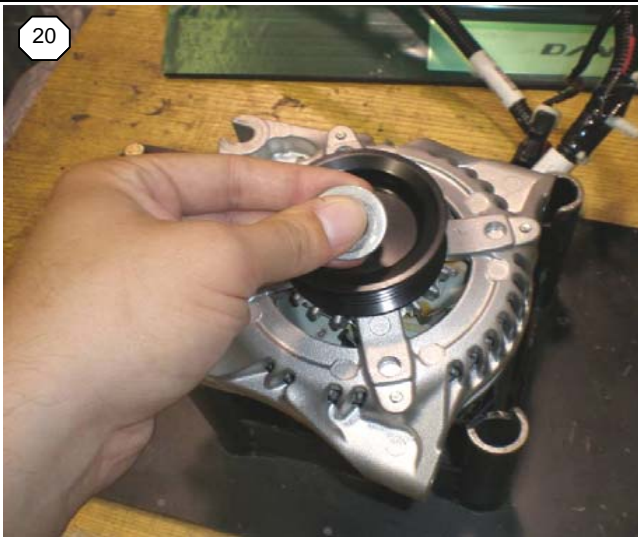

- 10 Retrieve the washer (A) and the 22mm nut (B) for the alternator. Apply a dab of red Loctite to the threads of the alternator nut.
- 20 Slide the washer over the alternator input shaft and onto the pulley.
- 30 Thread the 22mm nut onto the alternator input shaft and while holding the pulley, run the nut down with an impact.

ITEM	PART NUMBER	QTY.	DESCRIPTION
A	00-9004-C18923	1	Washer 14mm
B	00-9003-C18922	1	Nut Hex Jam M14x1.5mm

NOTES:

TORQUE



PROCESS PAGE

REPLACE ALTERNATOR PULLEY

2009 VEHICLES

C

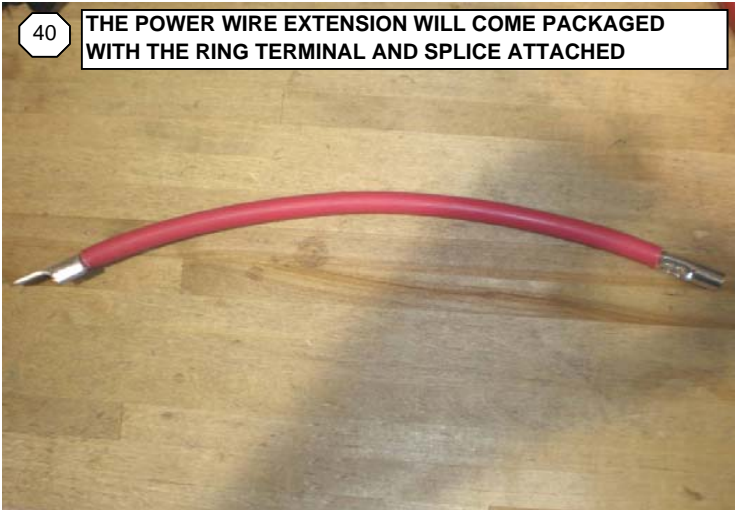
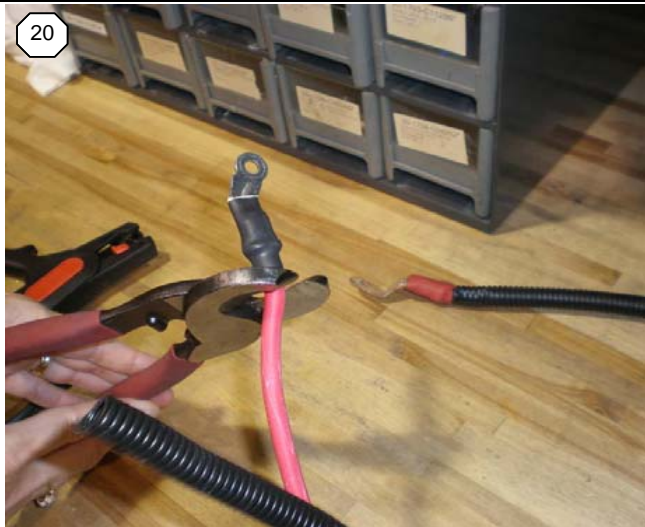
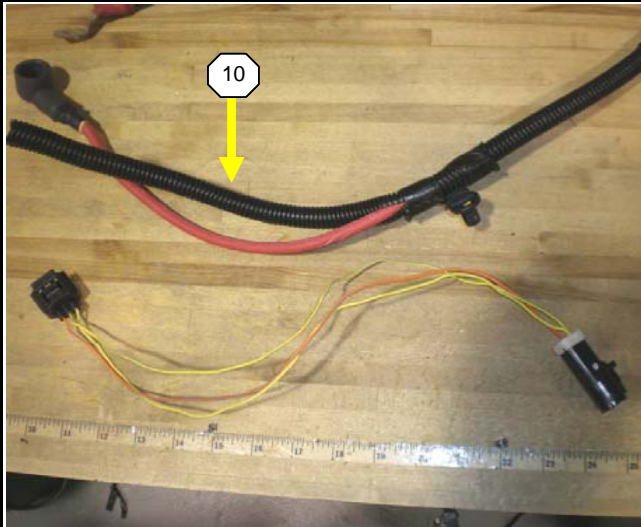

- 10 Retrieve a stock take-off alternator harness. Starting at the alternator end of the harness, cut the tape holding the convoluted sleeving together. Peel back the sleeving enough to remove the small 3-wire harness with the connector on each end.
- 20 Remove the grey rubber boot off of the alternator side of the harness. With large wire cutters, cut the alternator side ring terminal off of the red power wire.
- 30 Once the ring terminal is removed, strip the wire back as shown.
- 40 Retrieve the 10" section of red power wire (A), with the attached ring terminal (B) and splice (C).

ITEM	PART NUMBER	QTY.	DESCRIPTION
A	00-1703-C070810	10"	Wire, 4 AWG Red
B	00-1703-C070900	1	Terminal, Ring 4 AWG
C	00-1703-C162470	1	Splice, Non-Insulated 6 AWG Butt

NOTES:

TORQUE		
		PROCESS
		MODIFY ALTERNATOR HARNESS
		2005 - 2008 VEHICLES
		A
		B
		32

TORQUE

ITEM

OPERATION

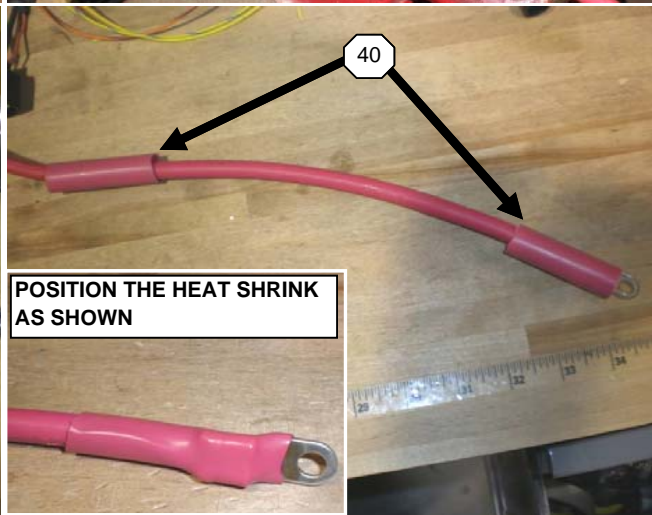
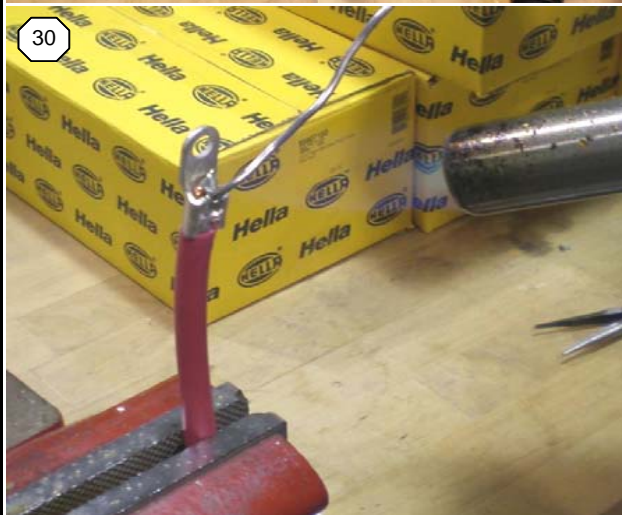

POSITION THE HEAT SHRINK AS SHOWN

10

20

30

40

10

20

30

40

Take the power wire extension from the previous page, and slide it onto the alternator harness power wire. With a crimping tool, attach the section to the alternator harness.

Clamp the newly extended power wire into a vise so that the small hole in the crimp is facing up. With a torch, heat up the splice and apply solder. Keep applying heat until the solder draws into the hole in the crimp.

Reposition the power wire in the vise so that the ring terminal is facing upward. With a torch, heat up the ring terminal and apply solder to the exposed copper wire. Keep applying heat until the solder draws into the wire and ring terminal.

Allow both the splice and the ring terminal to cool. Once cool, slide two 1.5" sections of red heat shrink (A) onto the power wire. One section will cover the splice while the other section will cover the crimped portion of the ring terminal. Apply heat to until each section of heat shrink is fully seated to the wire.

ITEM	PART NUMBER	QTY.	DESCRIPTION
A	00-1703-C070870	3"	Heat Shrink, Dual Wall 1/2" Red

NOTES:

TORQUE



PROCESS

MODIFY ALTERNATOR HARNESS

2005 - 2008 VEHICLES

PAGE

A

B

33

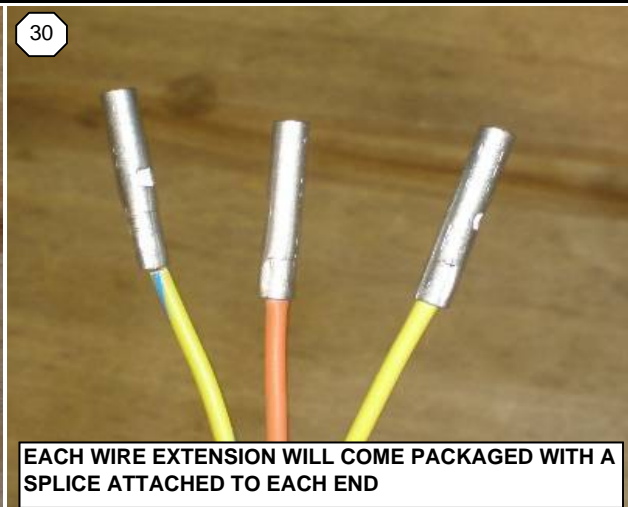
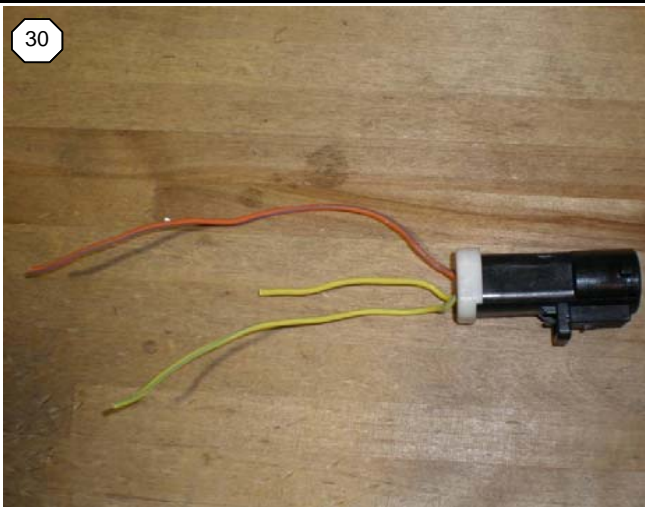

EACH WIRE EXTENSION WILL COME PACKAGED WITH A SPLICE ATTACHED TO EACH END

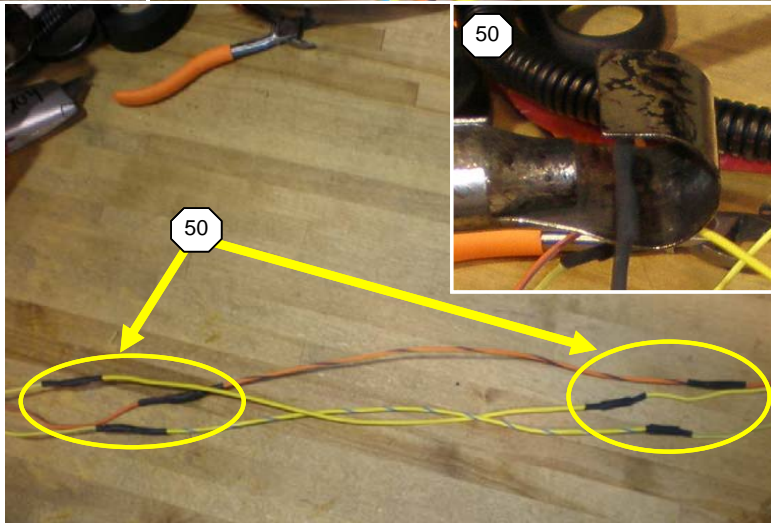
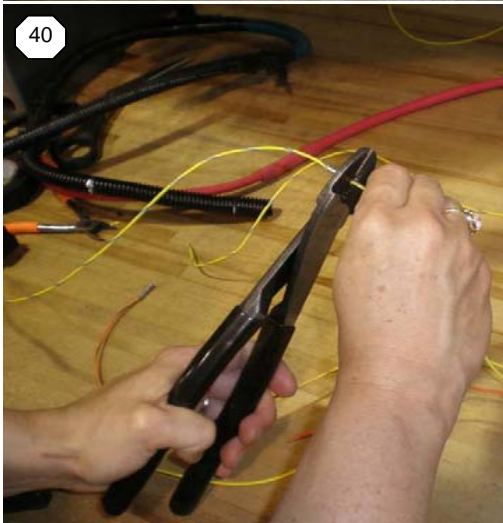

- 10 Retrieve the signal harness that was removed from the alternator harness on [Page 32AB](#), and cut the 3 wires near the barrel connector. Start by cutting the yellow wire 2" back from the connector, and then cut the remaining 2 wires farther down the harness. Make sure to stagger each cut so that the splices will not overlap.
- 20 After cutting the signal harness into two pieces, strip the wires. Slide heat shrink (A) onto each of the wires. There will be pieces of heat shrink total (2 per wire extension).
- 30 Obtain the three 12.25" signal wire extensions (a yellow wire (B), yellow wire w/ blue stripe (C), and an orange wire w/ blue stripe (D)). Each extension will come packaged with a splice (E) crimped on each end.
- 40 Attach each wire extension to the matching wire color of the signal harness (ex. Yellow harness wire to yellow extension wire). Use a tool to crimp each splice.
- 50 Once all three extensions are spliced into the signal harness, slide each piece of heat shrink over each butt splice. Apply heat to each piece of heat shrink to seat it in place.

ITEM	PART NUMBER	QTY.	DESCRIPTION
A	00-1704-C063000	9"	Heat Shrink, Dual Wall 1/8" Black
B	00-1704-C093820	12.25"	Wire, 20 AWG Yellow
C	00-1704-C129750	12.25"	Wire, 20 AWG Yellow w/ Blue
D	00-1704-C157540	12.25"	Wire, 20 AWG Orange w/ Blue
E	00-1704-C092600	6	Splice, Non-Insulated 18-20 AWG Butt

NOTES:

TORQUE



PROCESS

MODIFY ALTERNATOR HARNESS **A**

2005 - 2008 VEHICLES **B**

PAGE 34

TORQUE

ITEM

OPERATION

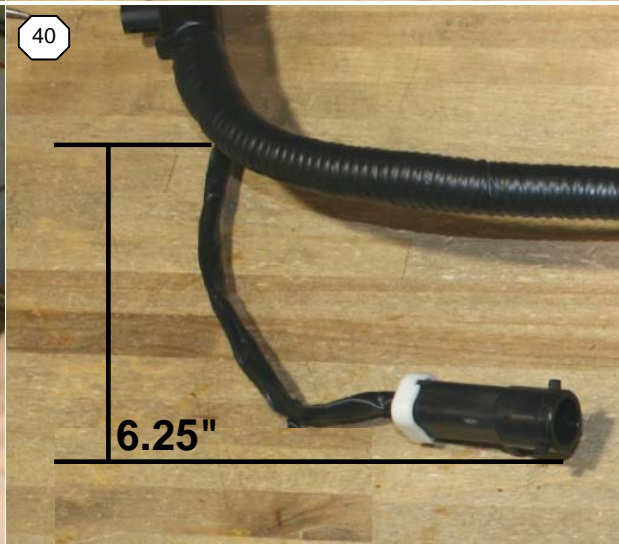
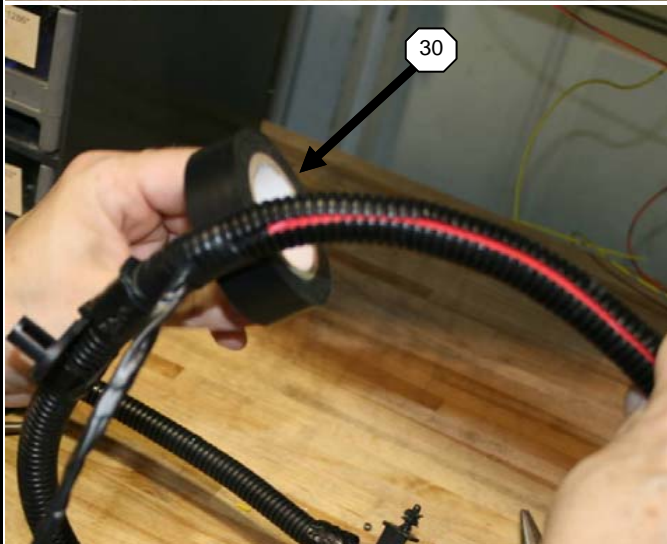
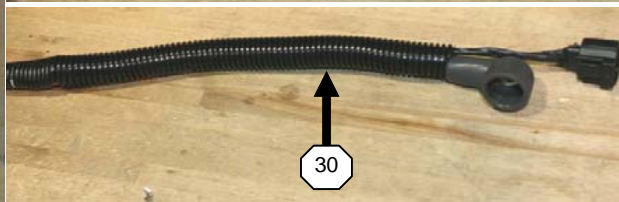

- 10 Wrap the signal harness from end to end in electric tape.
- 20 With electric tape, fasten the alternator signal harness to the power wire. Make sure the rectangular connector (that plugs into the alternator) over-reaches the alternator ring terminal by 2.5".
- 30 Once the alternator signal harness is placed and taped to the power wire, slide the convoluted tubing (A) over both harnesses. Tape the entire length of the new tubing with electric tape.
- 40 Make sure the barrel connector end of the signal harness protrudes from the alternator harness convolute sleeving by 6.25". Tape the convoluted tubing on both sides of the wire to keep it in place.

ITEM	PART NUMBER	QTY.	DESCRIPTION
A	00-1704-C110830	8.5"	Sleeving, Convoluted 1/2" Black

NOTES:

TORQUE



PROCESS PAGE

MODIFY ALTERNATOR HARNESS **A**

2005 - 2008 VEHICLES **B**

TORQUE

ITEM

OPERATION

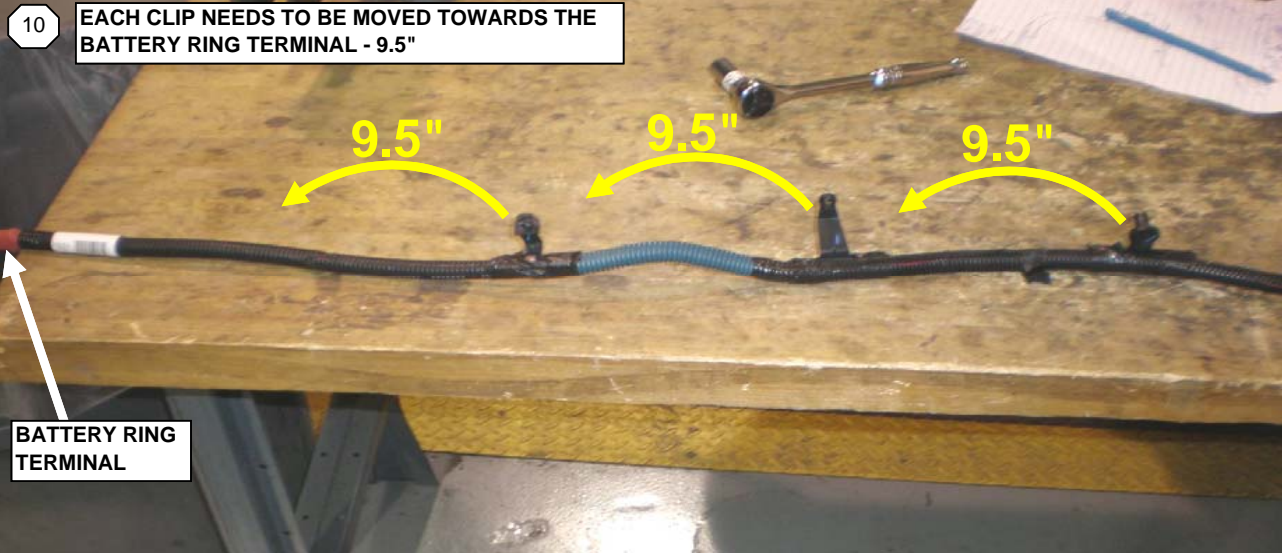

10 EACH CLIP NEEDS TO BE MOVED TOWARDS THE BATTERY RING TERMINAL - 9.5"

BATTERY RING TERMINAL



30

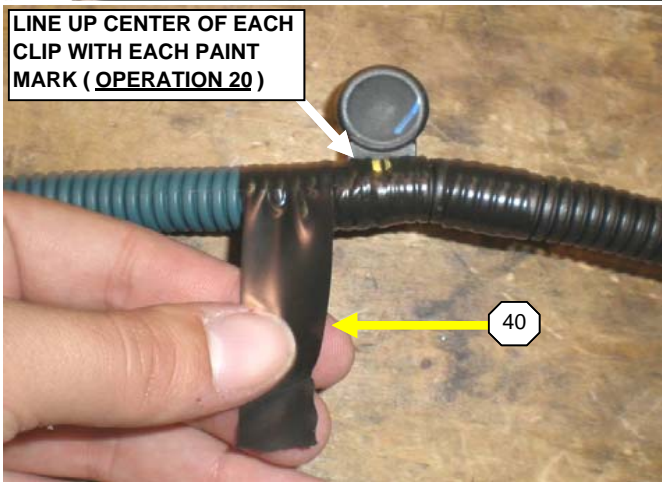

LINE UP CENTER OF EACH CLIP WITH EACH PAINT MARK (OPERATION 20)

40

- 10 Retrieve the take-off alternator harness. Set the harness on the work bench (stretched out). The 3 attachment clips taped to the harness (2 for the fuel rail, 1 for the bulkhead) will need to be moved towards the battery ring terminal 9.5".
NOTICE: Repeat **OPERATION 20** to **OPERATION 40** for each of the 3 clips on the alternator harness.
- 20 To move the clips, first find the center of each clip. Measure back towards the battery ring terminal 9.5". Mark that spot on the harness with a marker. Repeat for all three clips.
- 30 Start with the clip closest to the battery ring terminal. Look at the orientation of the clip (the clip will be orientated the same when it is re-attached to the harness). Carefully cut the clip free from the alternator harness, and remove any excess electric tape.
- 40 Line up the clip with the marker marking from **OPERATION 20**. Make sure the orientation of the clip is the same as it was before being removed. Re-attach the clip with electric tape.

ITEM	PART NUMBER	QTY.	DESCRIPTION

NOTES:

TORQUE			PAGE
		PROCESS	32
		MODIFY ALTERNATOR HARNESS	
		2009 VEHICLES	

TORQUE

ITEM

OPERATION

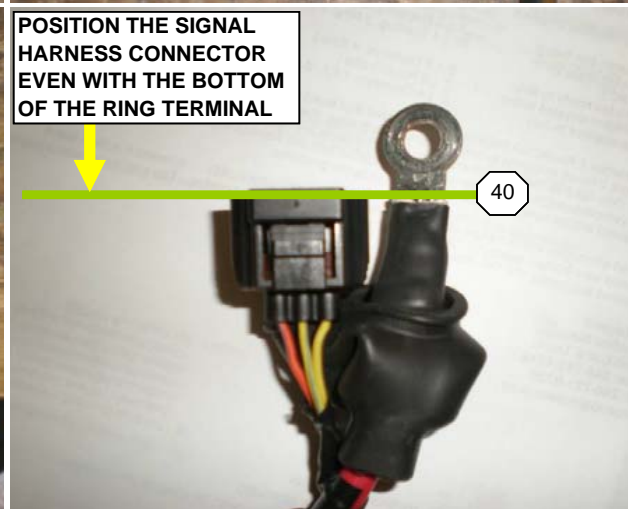
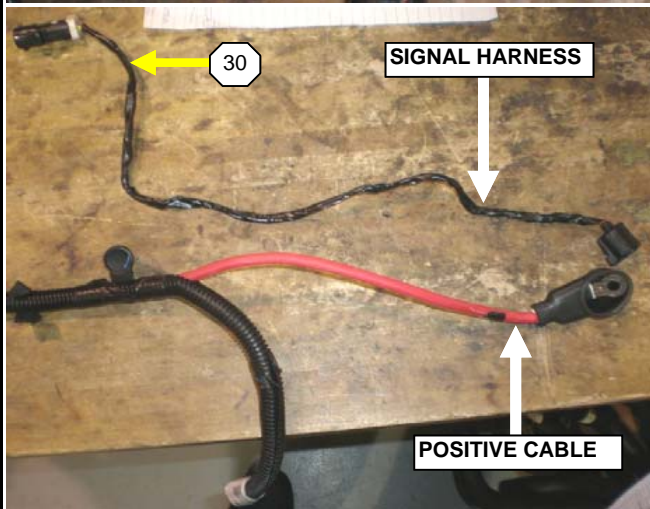
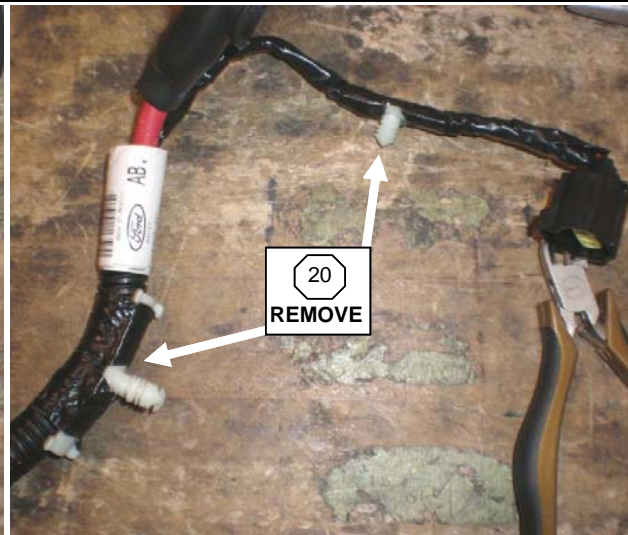

10 Proceed to the alternator end of the harness. With side cutters, remove the small zip tie holding the signal wire to the positive cable wire. The zip tie is located near the ring terminal boot.

20 Carefully remove the 2 white tree clips from the harness, by cutting the electric tape holding them in place with a razor. Remove any excess electric tape from the harness.

30 With a razor, carefully cut away any electric tape or label holding the convoluted tubing together. Peel back the convoluted tubing to expose the red positive cable and the signal harness. Carefully cut the electric tape holding the signal harness to the positive cable. Remove the signal harness.

40 Line up the alternator connector (signal harness) even with the bottom of the ring terminal as shown. Once the signal harness is in its new position, electric tape the signal harness to the positive cable.

ITEM	PART NUMBER	QTY.	DESCRIPTION

NOTES:

TORQUE



PROCESS PAGE

MODIFY ALTERNATOR HARNESS

2009 VEHICLES

C 33

TORQUE

ITEM

OPERATION

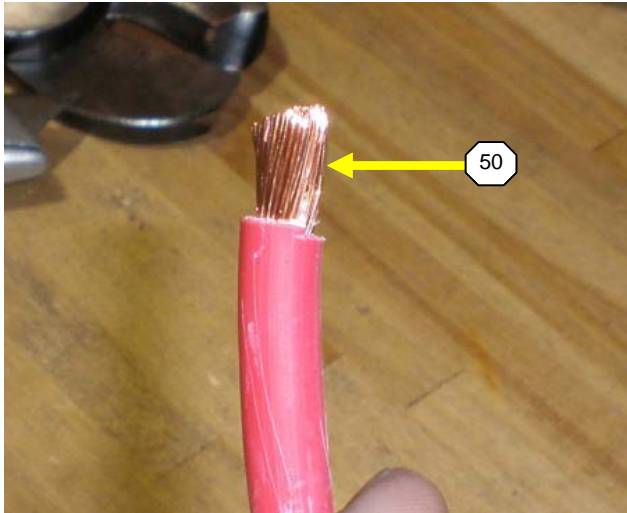
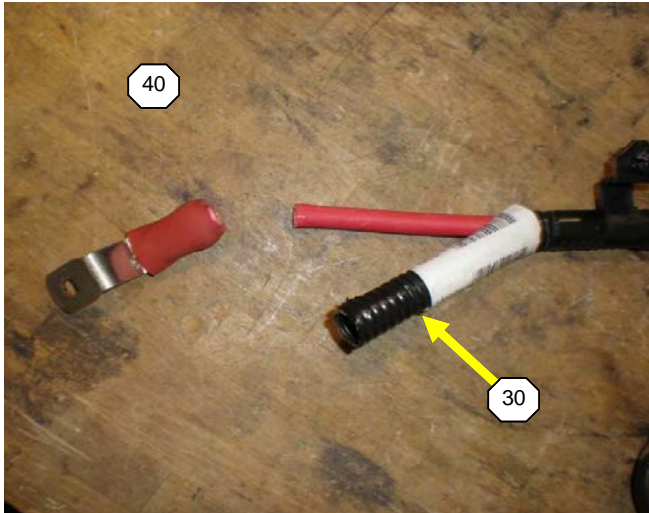
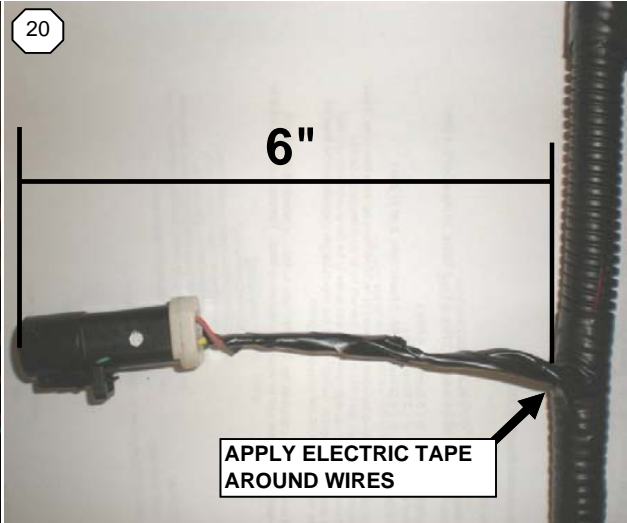

10 Once the signal harness is in position and secured to the positive cable, tuck the wires back into the convoluted tubing. Allow the signal harness to protrude about 0.5" from the end of the convoluted tubing. Wrap the harness with electric tape to keep the wires secure inside the convolute.

20 The engine harness connector on the end of the signal harness should be protruding 6" from the alternator harness convolute. Apply electric tape around the signal harness to keep the connector wire in place.

30 With a razor, cut the electric tape and label holding the convolute onto the harness on the battery terminal side. Peel back the convoluted tubing to reveal the positive cable.

40 Use cutters to remove the battery ring terminal from the positive cable. Make the cut just behind the ring terminal sheathing.

50 Once the ring terminal has been removed from the positive cable, strip the end of the cable.

ITEM	PART NUMBER	QTY.	DESCRIPTION

NOTES:

TORQUE			PROCESS	PAGE
		MODIFY ALTERNATOR HARNESS		C
		2009 VEHICLES		

10

THE ALTERNATOR POWER WIRE WILL BE PACKAGED WITH THE RING TERMINAL AND SPLICE ATTACHED



30

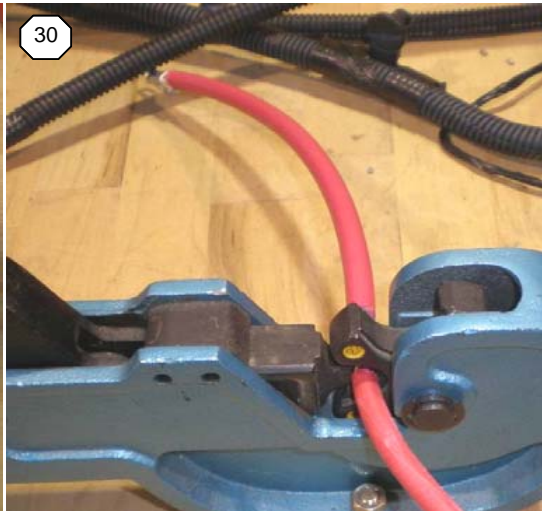

40



50



10

Retrieve the 10" section of red wire (A), with the attached splice (B) and ring terminal (C).

20

Take the positive cable extension and slide the open end of the splice over the stripped positive cable of the alternator harness. When orientating the extension, make sure the flat ring portion of the ring terminal is facing the bottom of the harness. this will make it easier for the operator to install it on the battery clamp.

30

Once the extension is positioned with the ring terminal facing downward, insert the harness into the crimping tool and crimp the splice. Make sure the extension is secure.

40

Clamp the newly extended power wire into a vise so that the small hole in the crimp is facing up. With a torch, heat up the splice and apply soldier. Keep applying heat until the soldier draws into the hole in the crimp.

50

Reposition the power wire in the vise so that the ring terminal is facing upward. With a torch, heat up the ring terminal and apply soldier to the exposed copper wire. Keep applying heat until the soldier draws into the wire and ring terminal.

ITEM	PART NUMBER	QTY.	DESCRIPTION
A	00-1703-C070810	10"	Wire, 4 AWG Red
B	00-1703-C070900	1	Terminal, Ring 4 AWG
C	00-1703-C162470	1	Splice, Non-Insulated 6 AWG Butt

NOTES:

TORQUE



PROCESS
 MODIFY ALTERNATOR HARNESS

2009 VEHICLES

PAGE

C

35

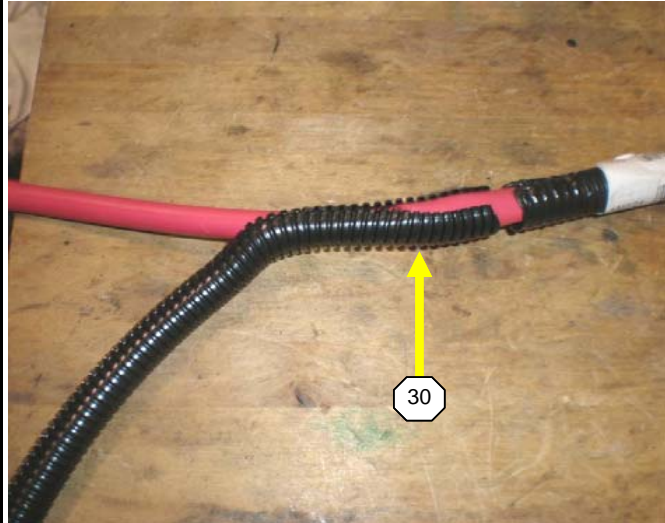
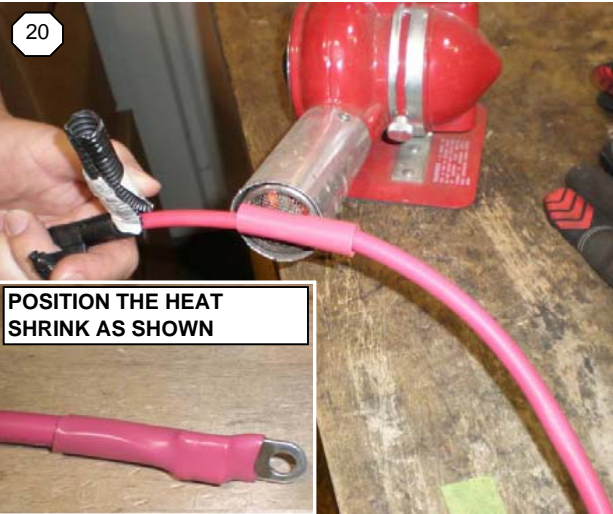
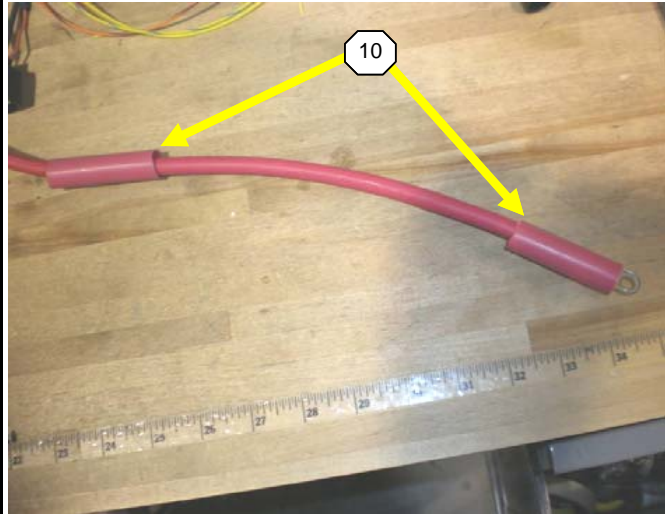

10 Allow both the splice and the ring terminal to cool. Once cool, slide two 1.5" sections of red heat shrink (A) onto the positive cable. One section will cover the splice while the other section will cover the crimped portion of the ring terminal.

20 Apply heat to until each section of heat shrink is fully seated to the positive cable. Make sure the heat shrink for the ring terminal is positioned as shown.

30 Retrieve the 10.5" section of 3/8" convoluted tubing (B). Apply the new convoluted tubing to the exposed portion of the alternator harness.

40 Once the new convolute is in position, secure it to the end of the existing convolute with electric tape. Electric tape the convolute together every 3". Once to the ring terminal, electric tape the end of the convoluted tubing to the base of the ring terminal (do not cover the ring portion itself).

ITEM	PART NUMBER	QTY.	DESCRIPTION
A	00-1703-C07087*	3"	Heat Shrink, Dual Wall 1/2" Red
B	00-1704-C12521*	10.5"	Sleeving, Convoluted 3/8" Black

NOTES:

TORQUE



PROCESS PAGE

MODIFY ALTERNATOR HARNESS

2009 VEHICLES

C

TORQUE

ITEM

OPERATION

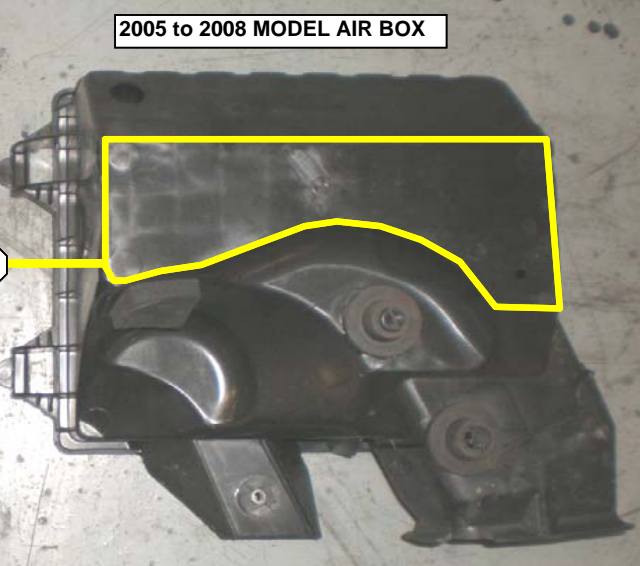
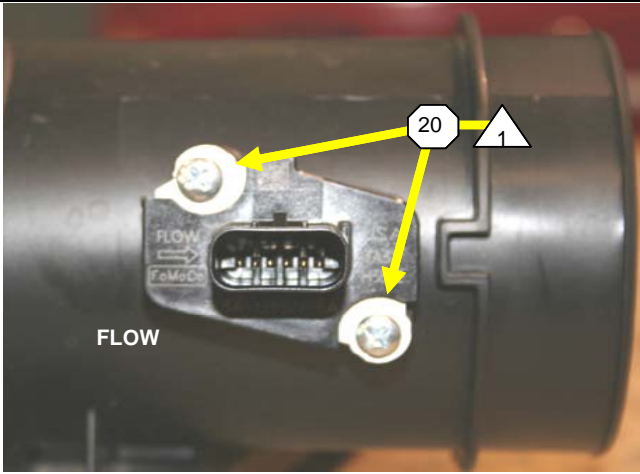
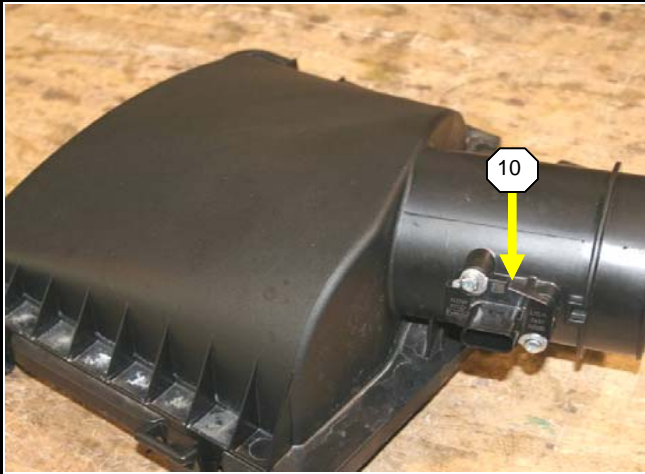

- 10 Retrieve the stock air box lid, and remove the MAF (Mass Air Flow) sensor from the neck of the lid with a T15 torx bit. It will be held in with two fasteners. Do not re-use the fasteners, two new ones are used.
- 20 Re-install the MAF (Mass Air Flow) sensor onto the new Saleen air box lid (A) with two screws (B) tightened to **18 Lb-in +/- 2.7 Lb-in**. Make sure the air flow arrow on the sensor is pointing towards the air inlet duct and motor.
- 30 With a reciprocating saw, cut and remove the bottom portion of the air box (flat portion). A pilot hole may need to be drilled in the bottom of the air box to create a starting point for the blade.
NOTICE: 2005 to 2008 vehicle air boxes are different then 2009. Refer to the photo for the correct cut-out for each box.
- 50 Smooth out the cut edges of the air box with an angle sander. If necessary, carefully remove any burrs with a razor blade.

ITEM	PART NUMBER	QTY.	DESCRIPTION
A	06-1602-C13093	1	Air Box Cover S281
B	00-9001-C13829*	2	Machine Screw M4x0.7x6 Phil Zn Steel

NOTES:

TORQUE		
1	18 +/- 2.7 Lb-in	
PROCESS		PAGE
ASSEMBLE AIR BOX AND LID		37

TORQUE

ITEM

OPERATION

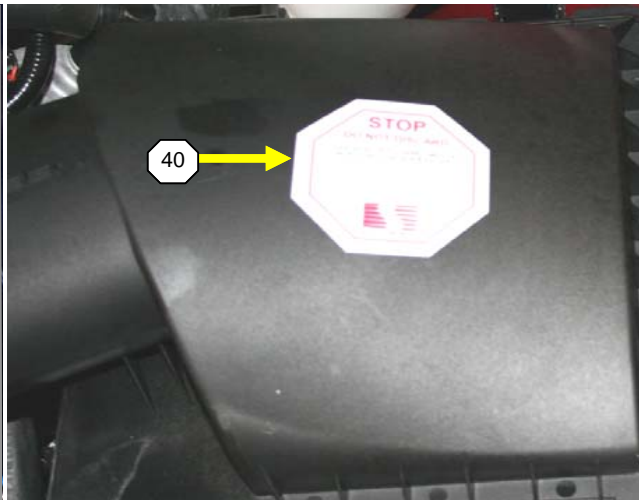
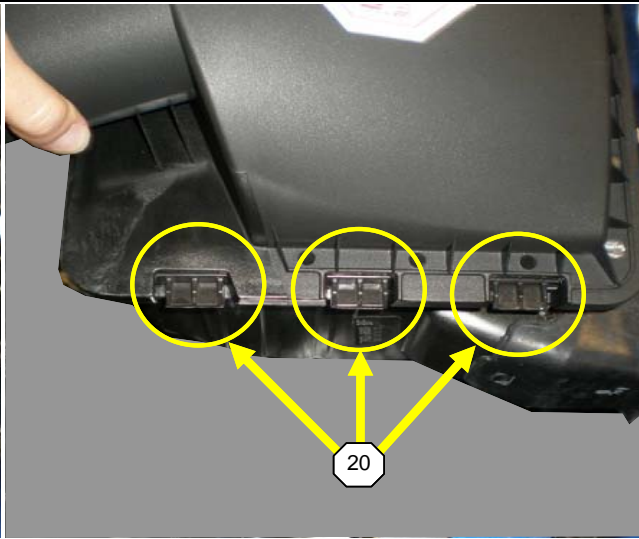

10 Set the new air filter (A) into the air box, and make sure it is fully seated.

20 Obtain the assembled air box lid. Slide the edge of the lid over the 3 tabs protruding from the edge of the box.

30 lower the lid onto the air box and engage the 2 clasps that lock the lid into place.

40 Prep the surface of the air box lid for the air filter stop decal (B) with an alcohol wipe. Install decal on the center of the lid. The decal should be facing forward.

ITEM	PART NUMBER	QTY.	DESCRIPTION
A	00-1602-C13944*	1	Air Filter S281
B	06-9101-B09867	1	Decal, Air Filter Stop

NOTES:

TORQUE



PROCESS PAGE

ASSEMBLE AIR BOX AND LID

TORQUE

ITEM

OPERATION

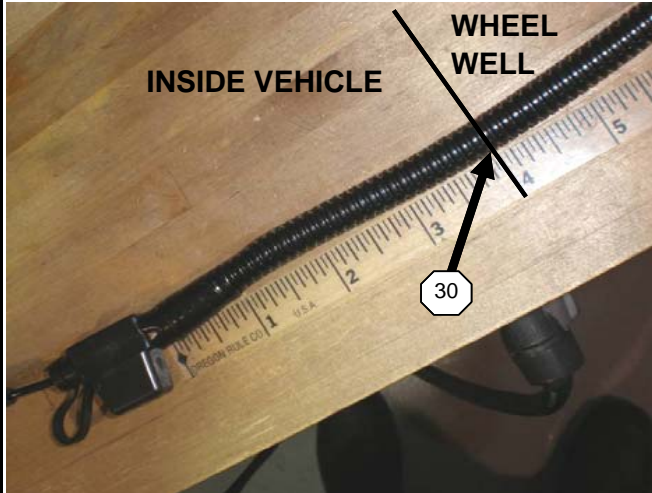
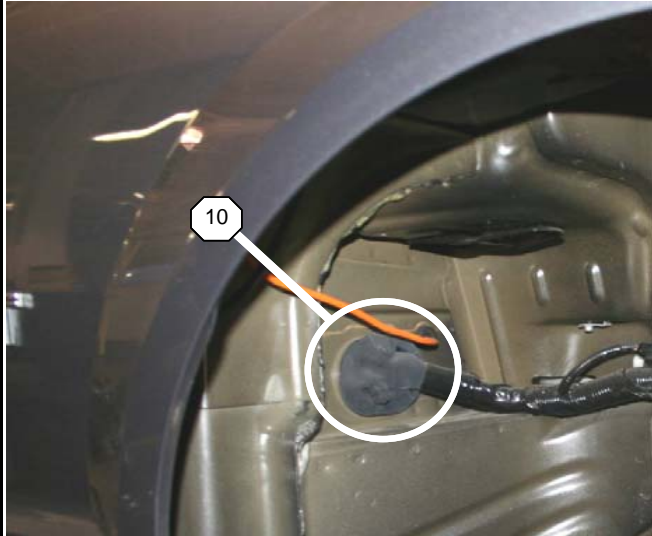

10 Locate the passenger (RH) bulkhead grommet in the RH side wheel well.

20 Locate the nub protruding from the grommet. Remove the nub with side cutters.

30 Retrieve the water pump harness (A). Locate the fuse holder on the water pump harness. Measure 4" back from the edge of the fuse holder and mark that spot with a paint marker.

NOTICE: When marking the harness, mark the convoluted tubing side of the fuse holder (with the water pump connector on the end). Do not mark the exposed wire side (white w/ yellow stripe).

50 Feed the end of the harness that gets wired into the SJB panel (exposed white w/ yellow stripe wire) through the bulkhead grommet. Stop feeding the harness into the vehicle once the paint mark is reached (OPERATION 30). The paint mark should be lined up with the outer edge of the grommet.

ITEM	PART NUMBER	QTY.	DESCRIPTION
A	06-1704-B16574	1	Harness, Mustang, Water Pump

NOTES:

TORQUE



PROCESS PAGE
ROUTE WATER PUMP HARNESS

TORQUE

ITEM

OPERATION

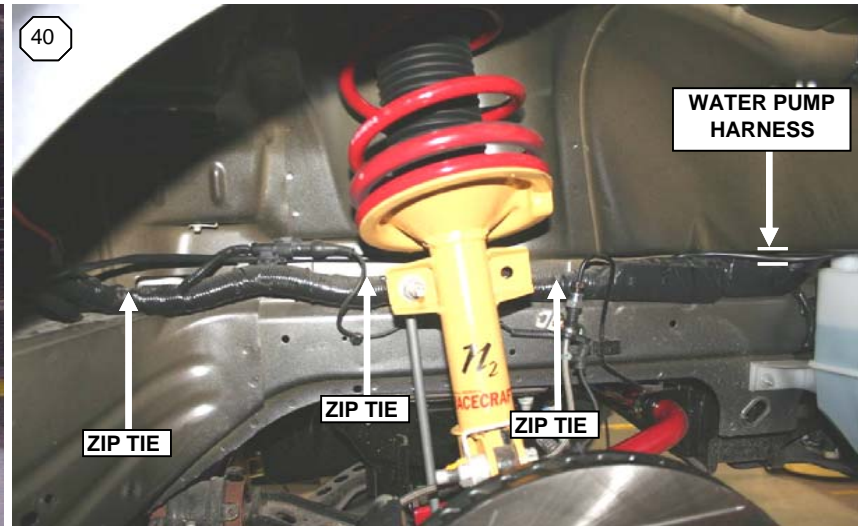
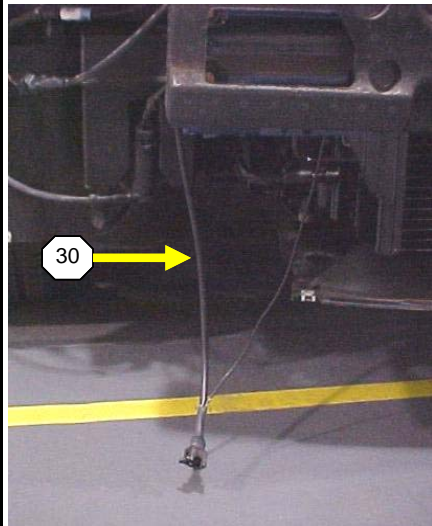
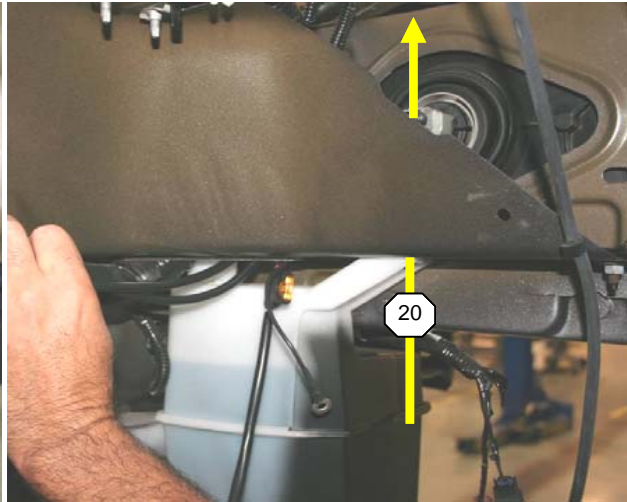

- 10 Feed the water pump harness along the main harness in the passenger (RH) wheel well.
- 20 Feed the water pump harness between the top of the washer fluid bottle and bottom of the wheel well along the front edge.
- 30 Continue routing the water pump harness over the washer bottle to the front of the vehicle. It will get plugged into the pump and grounded at a later step.
- 50 Once it has been verified that the water pump harness is positioned correctly, tuck the harnesses behind the larger main harness. Use 3 zip ties (A) to fasten the Saleen harness to the existing main harness in the passenger side (RH) wheel well in the three designated locations.

ITEM	PART NUMBER	QTY.	DESCRIPTION
A	00-9007-C10122*	3	7" Zip Tie

NOTES:

TORQUE



PROCESS PAGE

ROUTE WATER PUMP HARNESS

TORQUE

ITEM

OPERATION

6 of 7 RETAINERS SHOWN

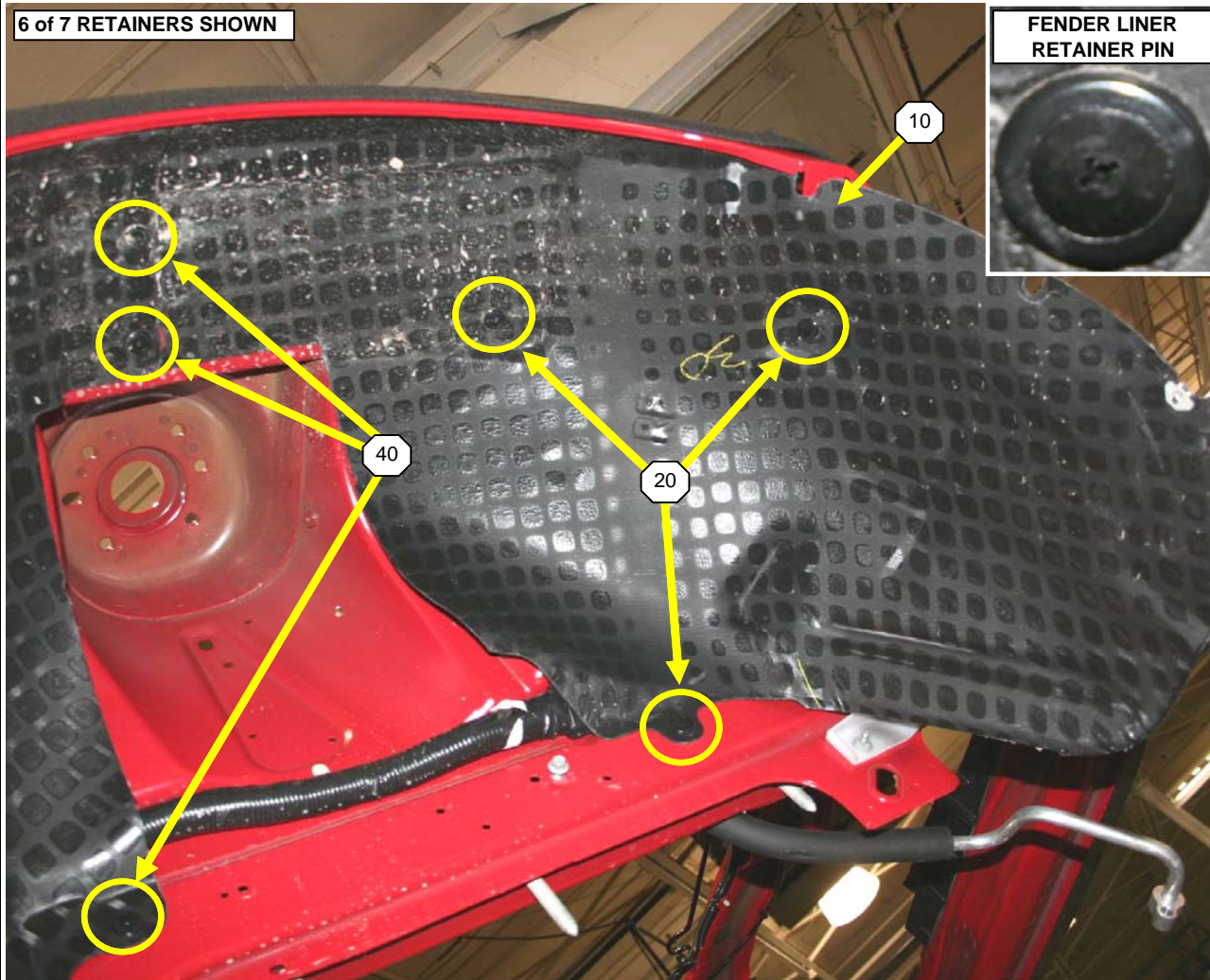

FENDER LINER RETAINER PIN

- 10 Set the front fender well liner into place at the front of the wheel well.
- 20 Line up the holes in the liner with the holes in the inner fender. Install 3 of the 7 retainer clips into the front liner to hold it into place.
- 30 Set the rear fender liner in place. To do so, feed the bottom of the liner behind the RH rocker cover. Next, overlap the front liner at the top of the fender well.
- 50 Line up the holes in the liner with the holes in the inner fender. Install 4 of the 7 retainer clips into the rear liner to hold it into place.

NOTICE: The 2 top retainers will be inserted into the rear liner and pass through the front liner before entering the fender.

ITEM	PART NUMBER	QTY.	DESCRIPTION

NOTES:

TORQUE



PROCESS

INSTALL RH FRONT FENDER LINERS

PAGE

TORQUE

ITEM

OPERATION

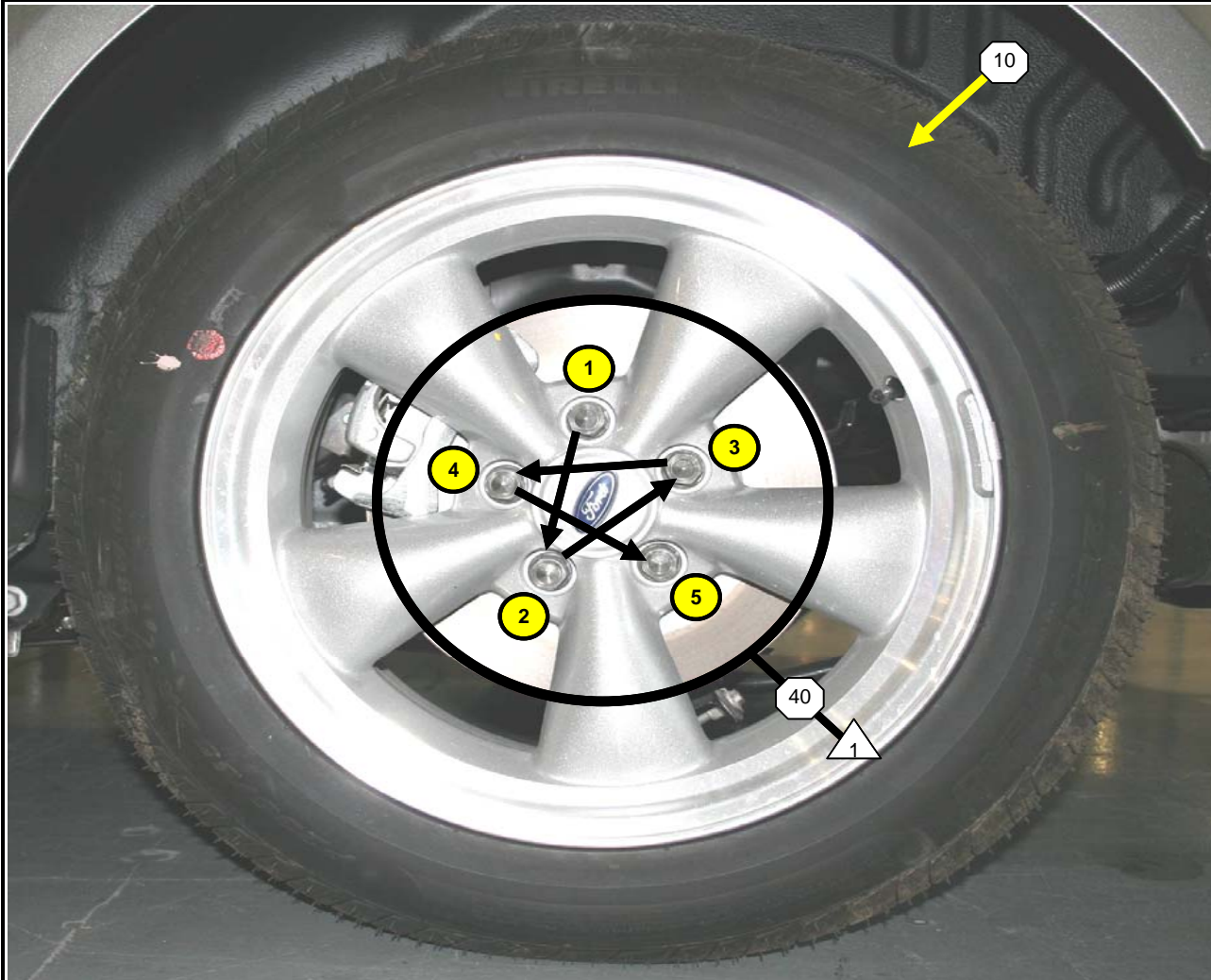

- 10 Slide the front wheels onto the hub on each side, and hand start each lug nut to help hold the wheel from sliding off of the hub.
- 20 Seat each lug nut to the wheel (lightly tightened). Do not completely torque the lug nuts, but snug them up so that the wheel is held firmly to the hub.
- 30 Verify all lug nuts and the wheels are firmly seated into place, and slowly lower the front of the vehicle onto the ground.
NOTE: When removing items like jack stands from under an elevated vehicle, use EXTREME CAUTION. Any time a vehicle is elevated off of the ground it may be unstable and have the potential to fall. Refer to the jack stand or floor jack owners manual for proper equipment operation and safety measures.
- 50 Make sure the parking brake is still set (to help prevent the vehicle from rolling) With a torque wrench and a 13/16" socket, torque the 5 lug nuts on each wheel (10 total) to **100 Lb-ft +/- 15 Lb-ft**. Make sure to torque each lug nut in a criss-cross pattern like the one shown (to evenly seat and secure the wheel).

ITEM	PART NUMBER	QTY.	DESCRIPTION

NOTES:

TORQUE

1 100 +/- 15 Lb-ft



PROCESS	PAGE
INSTALL RH WHEEL	42

TORQUE

ITEM

OPERATION

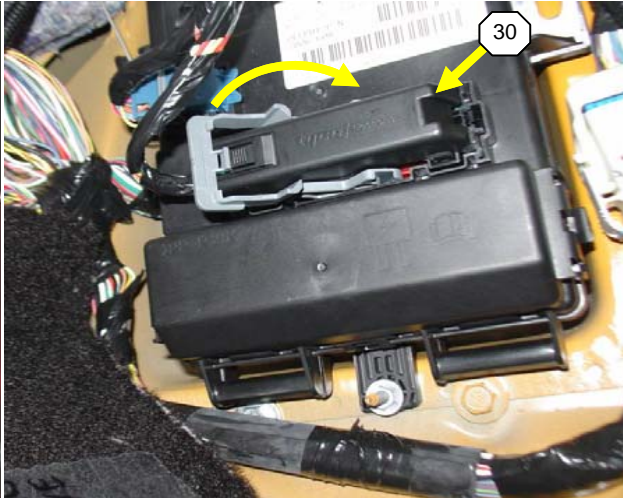

10

With a fiber stick, come in underneath the door sill trim and pry up until there is enough room to get a hold of the trim. Pull up on the door sill trim until it un-clips from the door sill frame. The door sill trim is held in by 4 clips.

20

Remove the passenger side kick panel trim by pulling directly rearward once the door sill trim is removed. This will expose the SJB panel. Lift up on the white weather cover.

30

Disconnect the wide SJB connector (36 pin connector) from the SJB panel by rotating the grey locking tab towards the rear of the vehicle. Once the lock is disengaged, pull the connector.

ITEM	PART NUMBER	QTY.	DESCRIPTION

NOTES:

TORQUE



PROCESS PAGE

WIRE WATER PUMP HARNESS INTO SJB MODULE CONNECTOR

TORQUE

ITEM

OPERATION

10



20

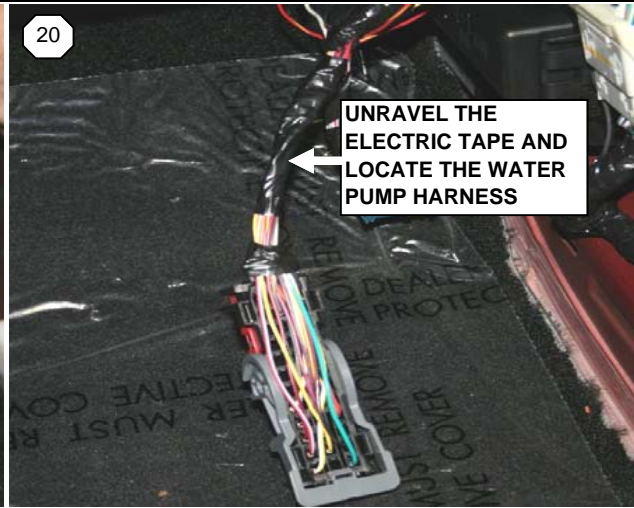

30

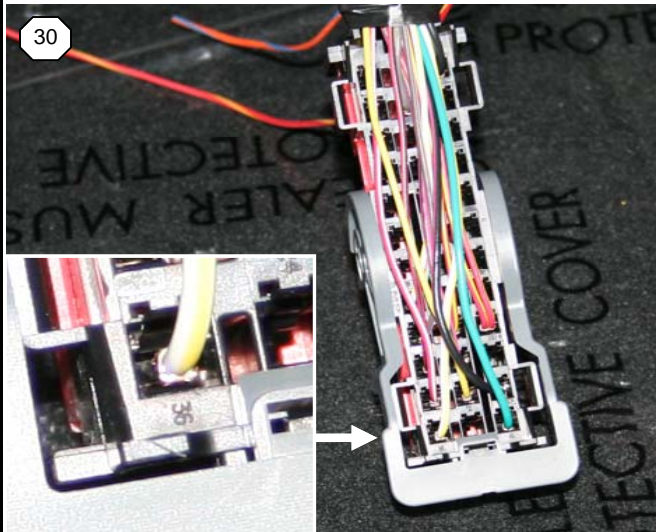

40

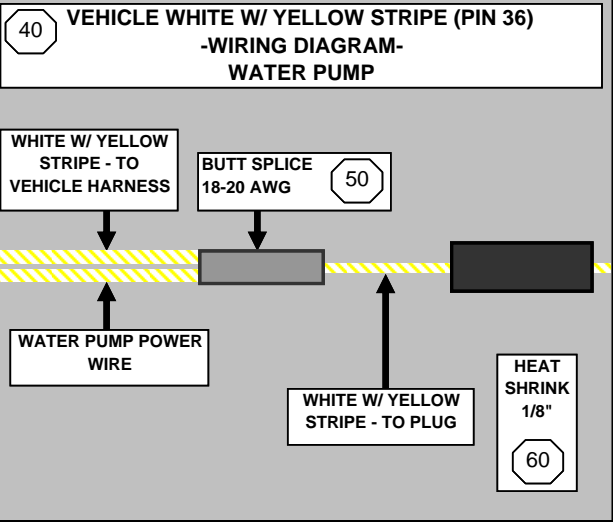

10

While lightly pulling on the cover, carefully use a flat head screwdriver to pop the 4 tabs holding the cover to the plug. The tabs are fragile so be careful.

20

Unwrap the harness going to the SJB connector and locate the water pump harness.

30

Locate pin # 36 in the SJB connector (located in the corner of the connector opposite the wires). The wire in pin #36 is white w/ yellow stripe.

40

Cut and strip the white w/ yellow stripe power wire from pin # 36.

50

Splice the water pump power wire (white w/ yellow) into the white w/ yellow striped wire in the connector (pin 36). Insert the wires into the butt splice (A) like shown in **DIAGRAM 40** (make sure the heat shrink (B) is added before crimping the splice).

60

Once the splice is crimped on both ends securing all wires, slide the heat shrink over the splice and apply heat.

ITEM	PART NUMBER	QTY.	DESCRIPTION
A	00-1704-C092600	1	Splice, Non-Insulated 18-20 AWG
B	00-1704-C063000	1.5"	Heat Shrink 1/8" Black

NOTES:

TORQUE



PROCESS PAGE

WIRE WATER PUMP HARNESS INTO SJB MODULE CONNECTOR

TORQUE

ITEM

OPERATION

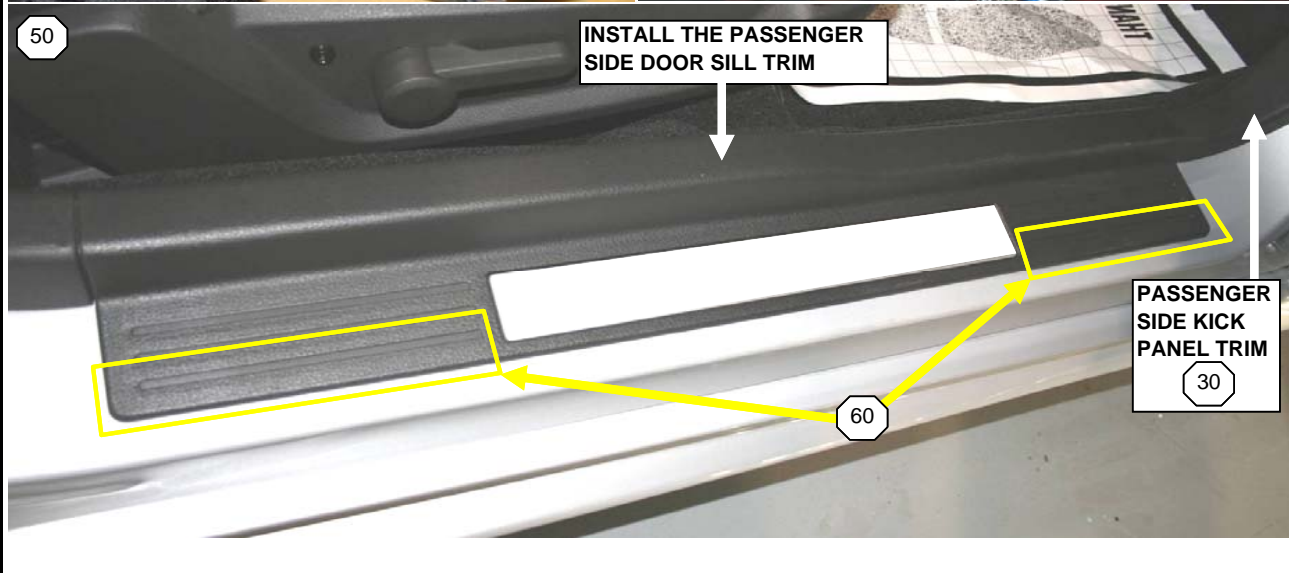

10 Wrap connector wires (with the water pump wire) with electric tape to secure them, and then re-install the cover onto the SJB connector.

20 Plug the connector into the SJB panel. Secure the connector to the SJB panel by engaging the grey locking clip. The connector will lock by pushing the clip towards the wires feeding the connector.

30 Re-cover the SJB with the white weather shield, and re-install the kick panel by sliding it forward to seat the clips.

50 Make sure the 4 clips located on the bottom of the door sill trim piece lines up with the 4 slots in the rocker sill. Also, make sure the locator pins (one on each side of the door sill trim) go into the holes in the existing trim.

60 Once the clips & locator pins are lined up with the rocker sill, firmly press the door sill trim panel into place.

70 Press the outboard edges of the door sill trim panel down against the rocker sill to help the 2-way tape bond.

ITEM	PART NUMBER	QTY.	DESCRIPTION

NOTES:

TORQUE			
		PROCESS	PAGE
		WIRE WATER PUMP HARNESS INTO SJB MODULE CONNECTOR	45

TORQUE

ITEM

OPERATION

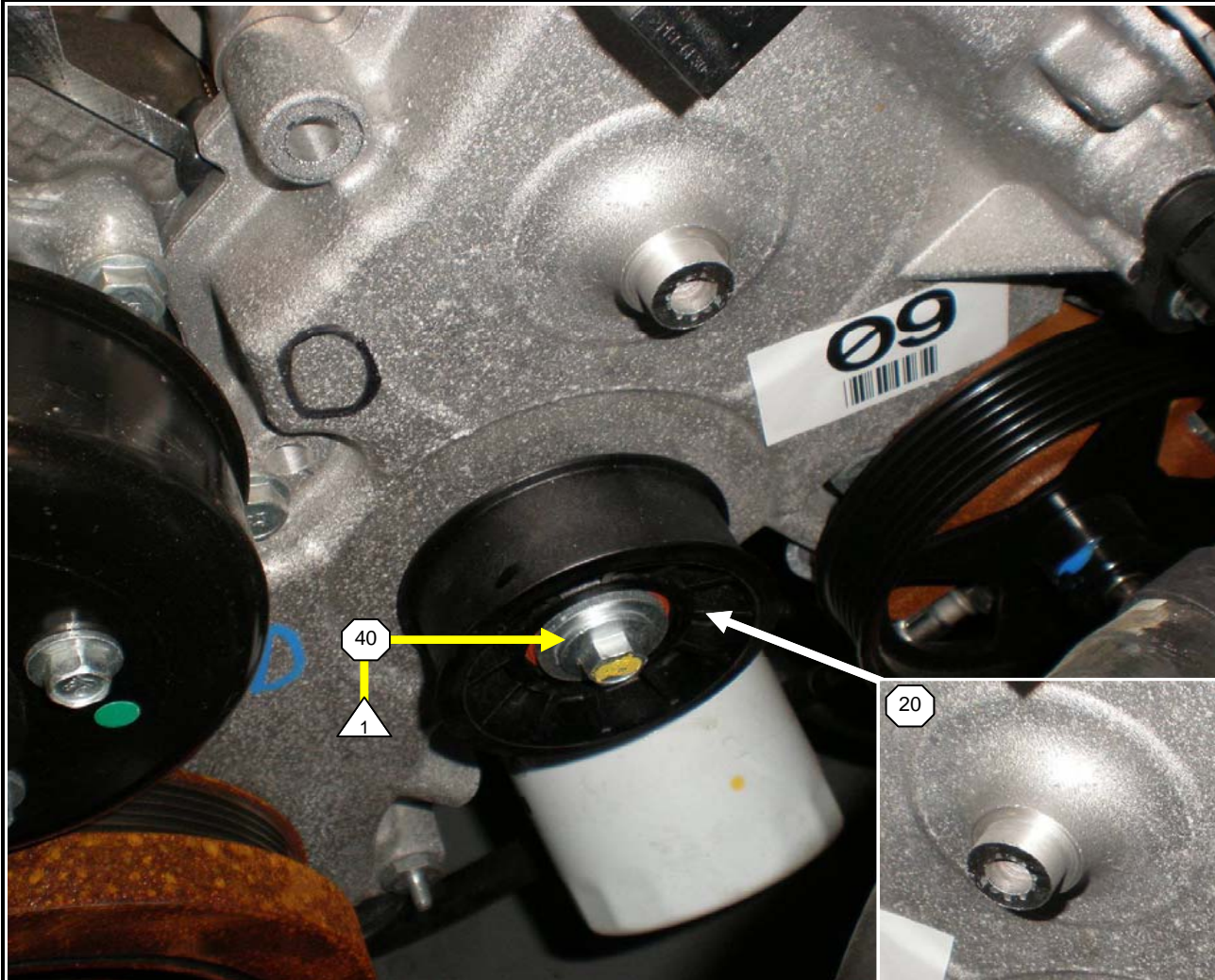

- 10 Apply red loctite to the threads of the 13mm stock bolt w/ washer that was removed from the lower pulley boss on [Page 23](#).
- 20 Retrieve the smooth guided pulley (A) and slide it over the lower driver side (LH) pulley boss.
- 30 Thread the bolt w/ washer into the pulley boss.
- 40 Tighten the bolt with a torque wrench to **18 Lb-ft +/- 2.7 Lb-ft**.

ITEM	PART NUMBER	QTY.	DESCRIPTION
A	00-1604-C09958*	1	Idler Pulley, 76mm, Guided

NOTES:

TORQUE

1 18 +/- 2.7 Lb-ft



PROCESS PAGE

INSTALL LOWER IDLER PULLEY

TORQUE

ITEM

OPERATION

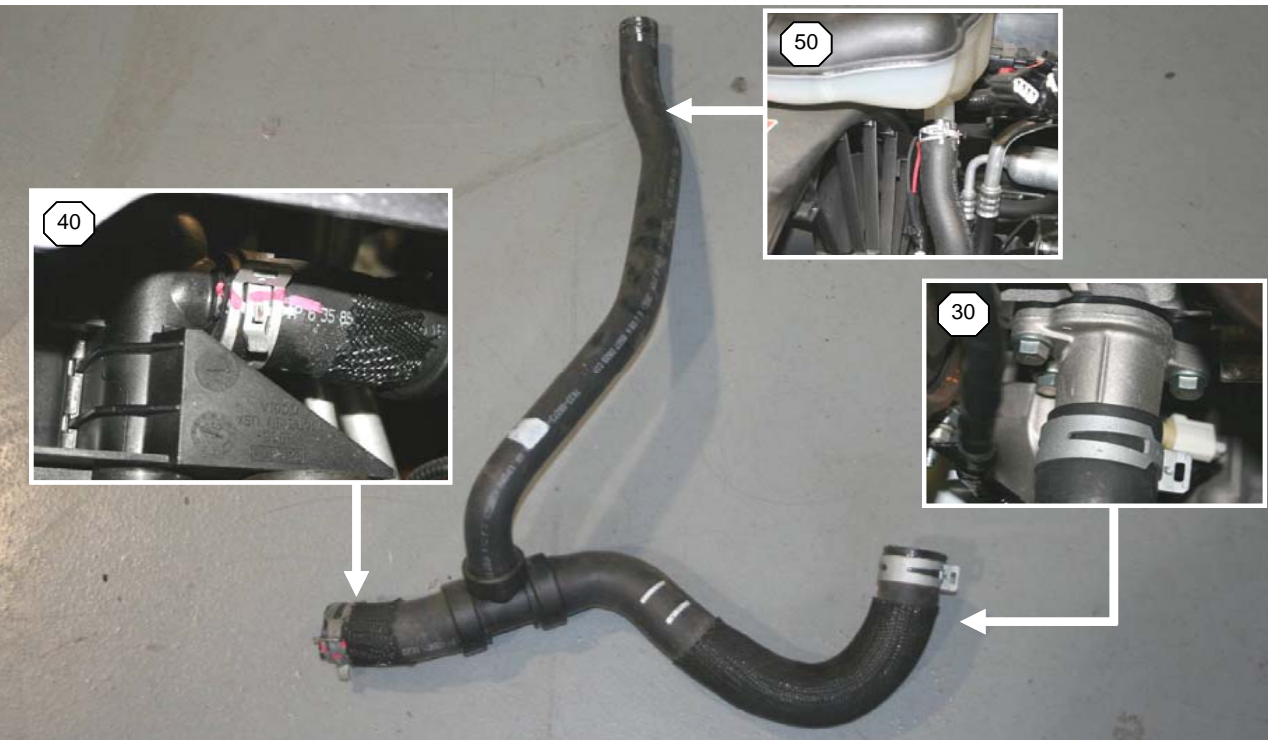

- 10 Using tension clamp pliers, install three tension clamps onto the new coolant hose assembly (A) removed from the old coolant hose assembly (Page 24A).
- 20 Lower the coolant hose assembly into place in front of the motor.
- 30 Install the hose shown to the oil filter adapter (located behind the power steering pump). Make sure to position and set the tension clamp properly to prevent leaks. Once connected, feed the hose into the retaining bracket.
- 40 Install the hose shown to the bottom of the radiator. Make sure to position and set the tension clamp properly to prevent leaks.
- 50 Install the remaining hose onto the bottom of the coolant reservoir bottle. Make sure to position and set the tension clamp properly to prevent leaks.

ITEM	PART NUMBER	QTY.	DESCRIPTION
A	00-2003-C19338	1	Coolant Hose Assy.

NOTES:

TORQUE



PROCESS

**INSTALL RADIATOR PLUMB.
CONVERSION KIT**

2005- 2006 VEHICLES

A

47

PAGE

▲ TORQUE

□ ITEM

⬡ OPERATION

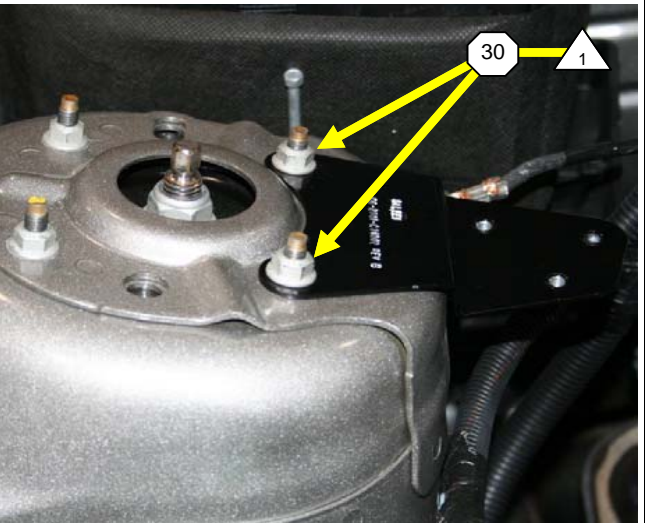
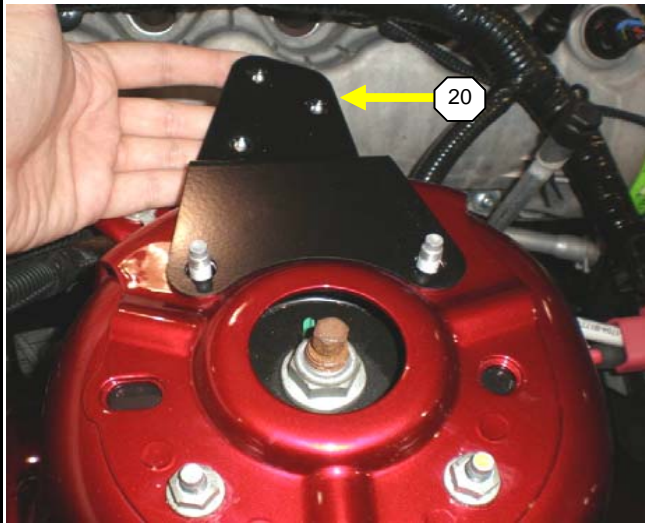

⬡ 10 Remove the 13mm upper strut nuts that are closest to the engine (inboard).

⬡ 20 Once the 2 nuts are removed, retrieve the reservoir tank bracket. Orientate the bracket so that it steps downward, and then slip it over the 2 inboard strut studs.

⬡ 30 Apply blue Loctite to the threads of the two 13mm strut nuts removed in **OPERATION 10**. Thread the nuts onto the strut nuts, and torque to **26 Lb-ft +/- 3.9 Lb-ft** with a torque wrench.

ITEM	PART NUMBER	QTY.	DESCRIPTION
A	06-2001-C14002	1	Bracket, Tank Intercooler Recovery

NOTES:

TORQUE			PROCESS	PAGE
▲ 1	26 +/- 3.9 Lb-ft			
		2007 - 2009 VEHICLES		C
				48

TORQUE

ITEM

OPERATION

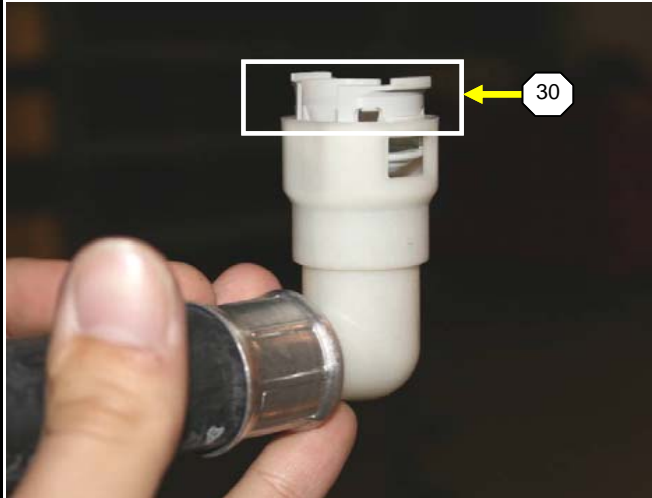
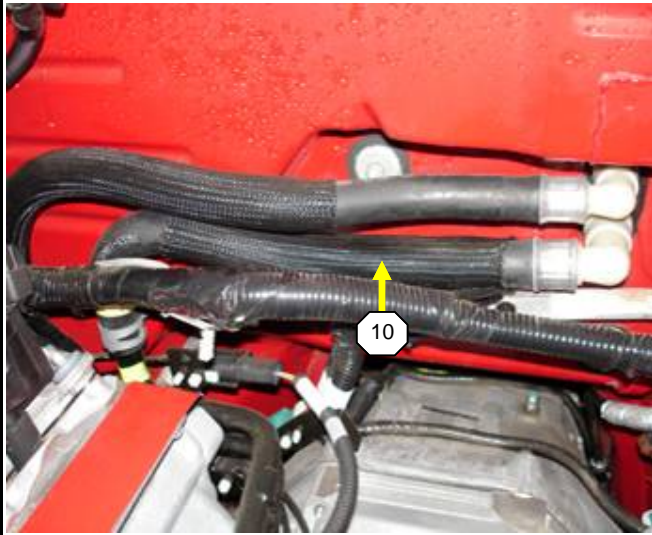

- 10 Locate the lower heater hose and remove it from the heater core tube in the bulkhead. To release the fitting for the hose, push the fitting towards the bulkhead and then press in the two side clips. While pressing the two clips in, Pull the fitting away from the bulkhead.
- 20 Once the stock lower heater hose is removed, check to make sure the white locking clip has remained on the heater core tube.
- 30 Retrieve the new heater hose (A), and remove the white locking clip from inside the new hose fitting. The clip won't be needed, since the old locking clip (the one from **OPERATION 20**) will be used instead.
- 40 Install the heater hose by pressing it onto the heater core tube. Press the hose fitting until it clicks (the locking clip fully engages the hose fitting).

ITEM	PART NUMBER	QTY.	DESCRIPTION
A	06-2003-C143800	1	Hose, Heater, Lower

NOTES:

TORQUE



PROCESS PAGE

REPLACE LOWER HEATER HOSE

TORQUE

ITEM

OPERATION

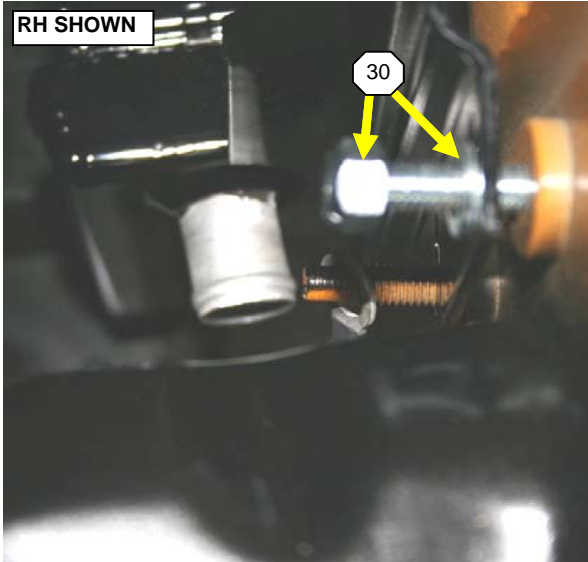
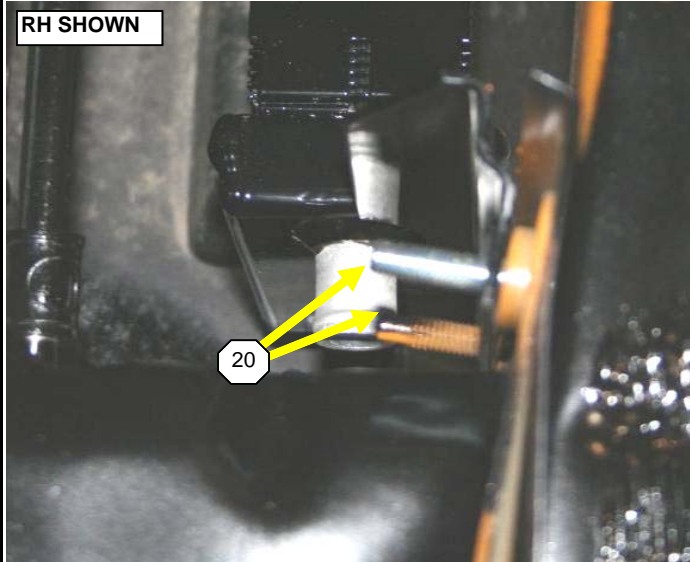
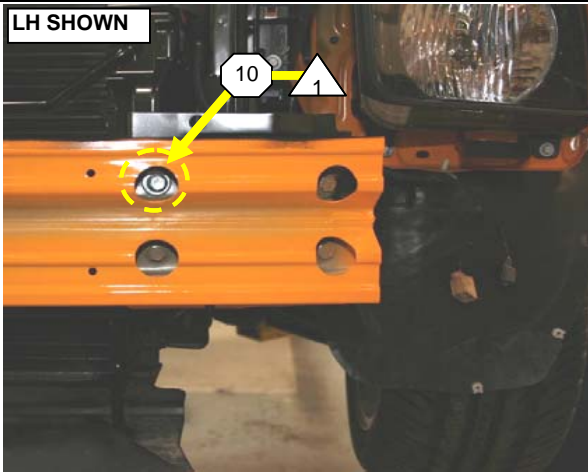

- 10 Install two 13mm bolts (1 per side) (A) with two washers (1 per side) (B) into the open hole in the bumper mount on each side. Tighten each bolt to **18 Lb-ft +/- 2.7 Lb-ft.**
- 20 Slide the heat exchanger (C) (with the brackets pointed up) over the two bolts just installed in **OPERATION 20**, and the two stock bolts located below it.
- 30 Slide four washers (D) over the four heat exchanger mounting bolts and **HAND TIGHTEN** four 13mm nuts (E). Leave the nuts loose to allow play in the heat exchanger. This will make installing the hose running between the heat exchanger and intercooler water pump easier to install. The nuts will be tightened during the intercooler water pump installation **Page 53.**

ITEM	PART NUMBER	QTY.	DESCRIPTION
A	00-9001-C135810	2	Bolt M8x1.25mm 30mm CL 8.8 Zn
B	00-9004-C114890	2	Washer M8 24mm OD 2mm THK Zn
C	06-2001-C09599	1	Heat Exchanger S/C, Mustang
D	00-9004-C001740	4	Washer Flat M8 ST
E	00-9003-C157270	4	Nut M8 X 1.25 Distorted Thrd Locknut

NOTES:

TORQUE			PROCESS	PAGE
1	18 +/- 2.7 Lb-ft			
		2007 to 2009 VEHICLES		C
				50

TORQUE

ITEM

OPERATION

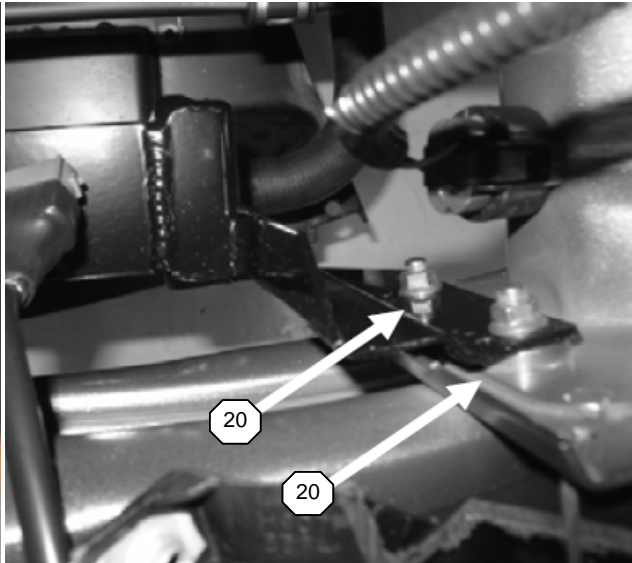
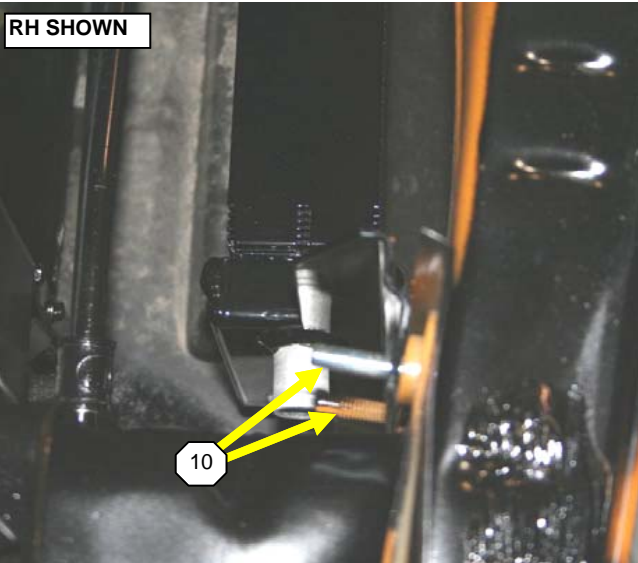

- 10 Slide the heat exchanger (A) (with the brackets pointed up) over the 4 factory bolts protruding from the back side of the bumper.
- 20 Thread on, and HAND TIGHTEN four jet nuts (B) (1 for each bolt). Leave the nuts loose to allow play in the heat exchanger. This will make installing the hose running between the heat exchanger and intercooler water pump easier to install. The nuts will be tightened during the intercooler water pump installation [Page 53](#).

ITEM	PART NUMBER	QTY.	DESCRIPTION
A	06-2001-C09599	1	Heat Exchanger S/C, Mustang
B	00-9003-C001370	4	Jetnut M8x1.25

NOTES:

TORQUE



PROCESS

INSTALL HEAT EXCHANGER

2005 to 2006 VEHICLES

A

50

TORQUE

ITEM

OPERATION

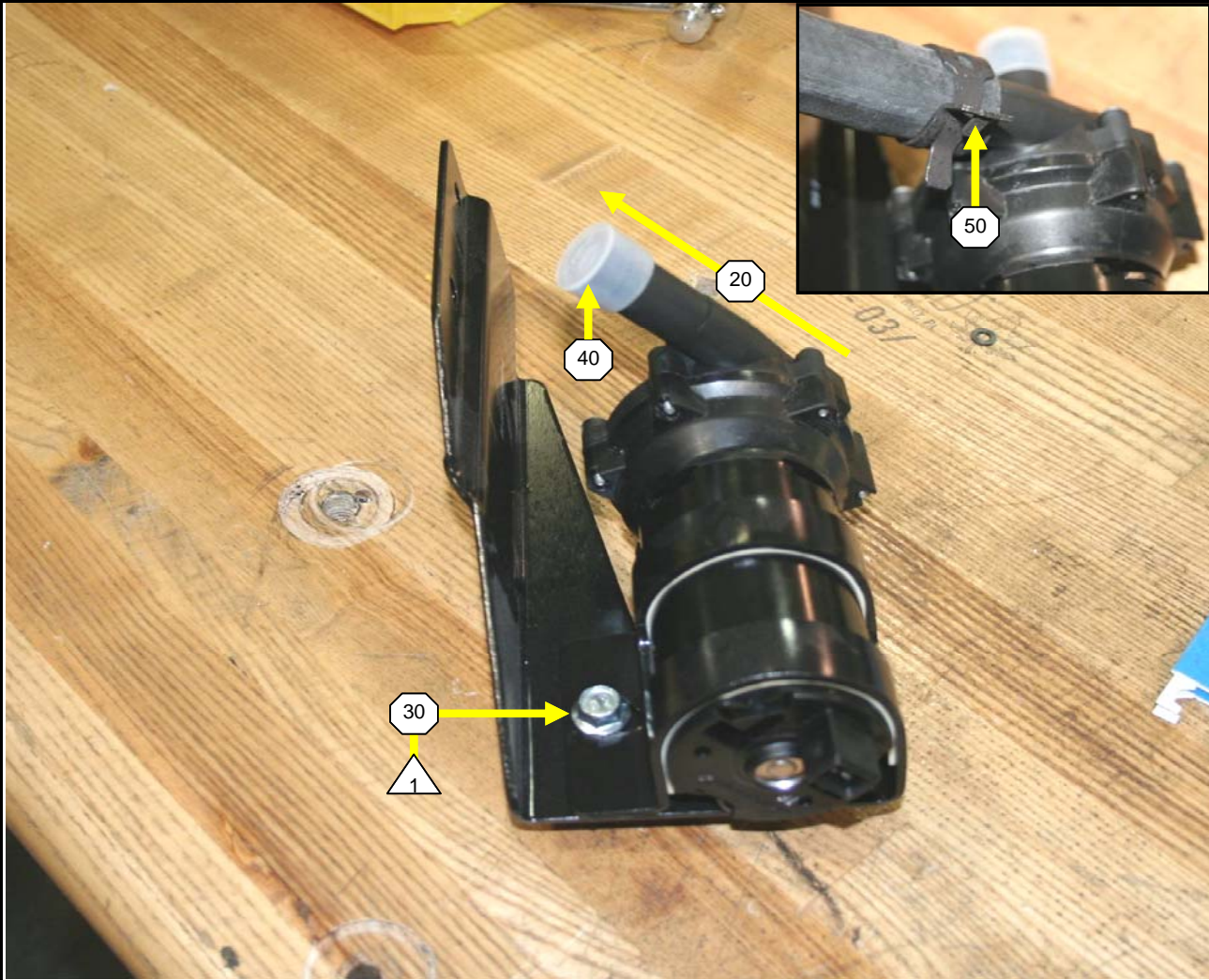

- 10 Retrieve the intercooler water pump (A) and insert the pump into the intercooler water pump bracket (B).
- 20 Orientate the intercooler water pump as shown.
- 30 Once positioned, secure the intercooler water pump in the bracket with one 12mm bolt (C). With a torque wrench, tighten the bolt to **18 Lb-ft +/- 2.7 Lb-ft.**
- 40 Remove the protective cap off of the pump outlet fitting.
- 50 Attach the 7.5" long 3/4" Dia. Hose (D) to the pump outlet fitting and attach with one clamp (E).

ITEM	PART NUMBER	QTY.	DESCRIPTION
A	00-2002-C09991*	1	Intercooler Water Pump
B	06-2002-C09888	1	Bracket, Intercooler Water Pump
C	00-9001-C10064*	1	Capscrw Hex Flng M8x1.25mm 20mm
D	069-950	1	3/4" Heater Hose
E	00-2003-C10068*	1	Hose Clamp

NOTES:

TORQUE		
1	18 +/- 2.7 Lb-ft	
PROCESS		PAGE
INSTALL WATER PUMP		51

TORQUE

ITEM

OPERATION

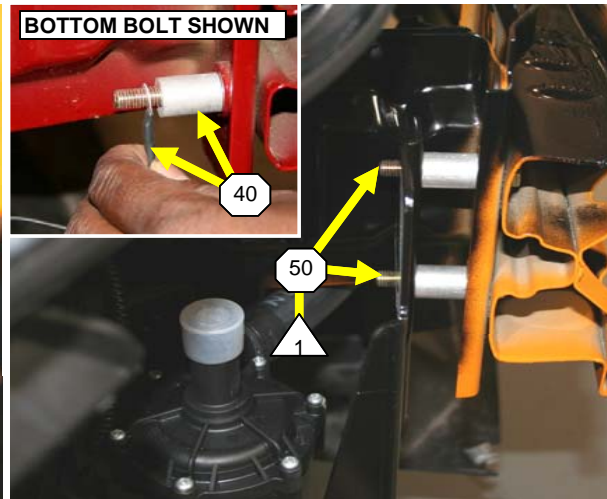
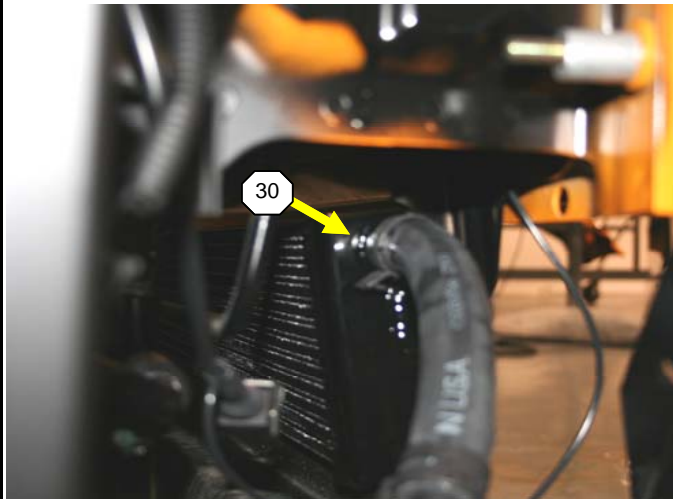
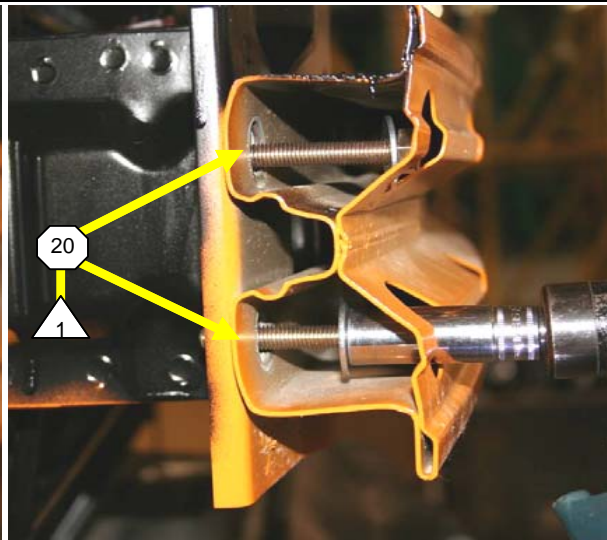
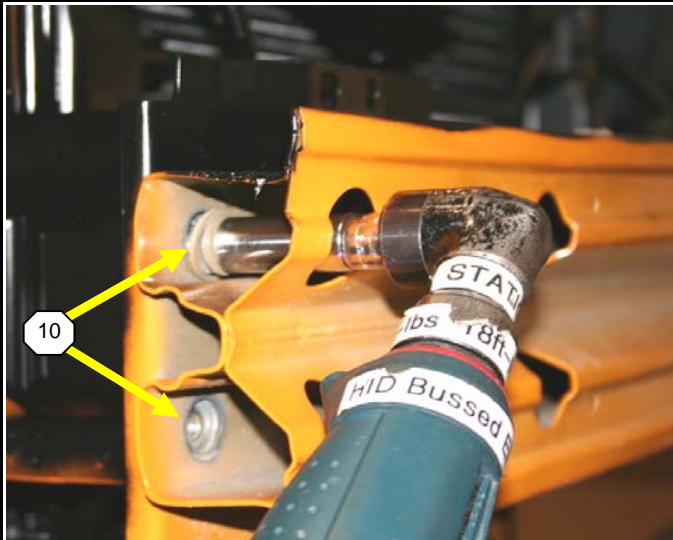

- 10 Remove the two stock outside 13mm bolts attaching the bumper to the RH bumper mount.
- 20 Slide the washer (A) onto the 13mm bolt (B) (two total) and install them into the bumper where the two stock bolts were removed in **OPERATION 10**. Tighten the bolts to **18 Lb-ft +/- 2.7 Lb-ft** with a torque wrench.
- 30 Retrieve the intercooler water pump assembly (built on page 1) and attach the open end of the hose from the water pump onto the heat exchanger with one clamp (C).
- 40 Slide two spacers (D) (1 per bolt) over the bolts installed in **OPERATION 20**. Slide the ring terminal for the water pump harness ground over the bolt as shown. The ground will sit between the spacer and the water pump bracket.
- 50 Slide the intercooler water pump bracket onto the bolts. Install two washers (E) and two 13mm nuts (F) to lock the assembly into place. Tighten the nuts to **18 Lb-ft +/- 2.7 Lb-ft** with a torque wrench.

ITEM	PART NUMBER	QTY.	DESCRIPTION
A	00-9004-C11489*	2	Washer Flat M8 24mm OD 2mm Thk
B	00-9001-C11465*	2	Capscrw Hex HD M8x1.25x50 Full Thrd
C	00-2003-C10068*	1	Hose Clamp
D	06-2002-C11237	2	Spacer, Water Pump Bracket
E	00-9004-C00174*	2	Washer Flat M8 ST
F	00-9003-C15727*	2	Nut M8 X 1.25 Dist. Thrd Locknut Zn

NOTES:

TORQUE

1 18 +/- 2.7 Lb-ft



PROCESS	PAGE
INSTALL WATER PUMP	52



TORQUE



ITEM



OPERATION



10

Now tighten down the four 13mm nuts holding the heat exchanger to the bumper mount bolts installed in an earlier process. Tighten the nuts to **18 Lb-ft +/- 2.7 Lb-ft** with a torque wrench.

20

Re-install the front bumper upper isolator and lower isolator. The lower isolator is retained by four tree push pins that push into the bumper beam. The upper isolator drops onto the top of the bumper beam and locks into the lower isolator.

ITEM	PART NUMBER	QTY.	DESCRIPTION

NOTES:

TORQUE

1

18 +/- 2.7 Lb-ft



PROCESS PAGE

INSTALL WATER PUMP

TORQUE

ITEM

OPERATION

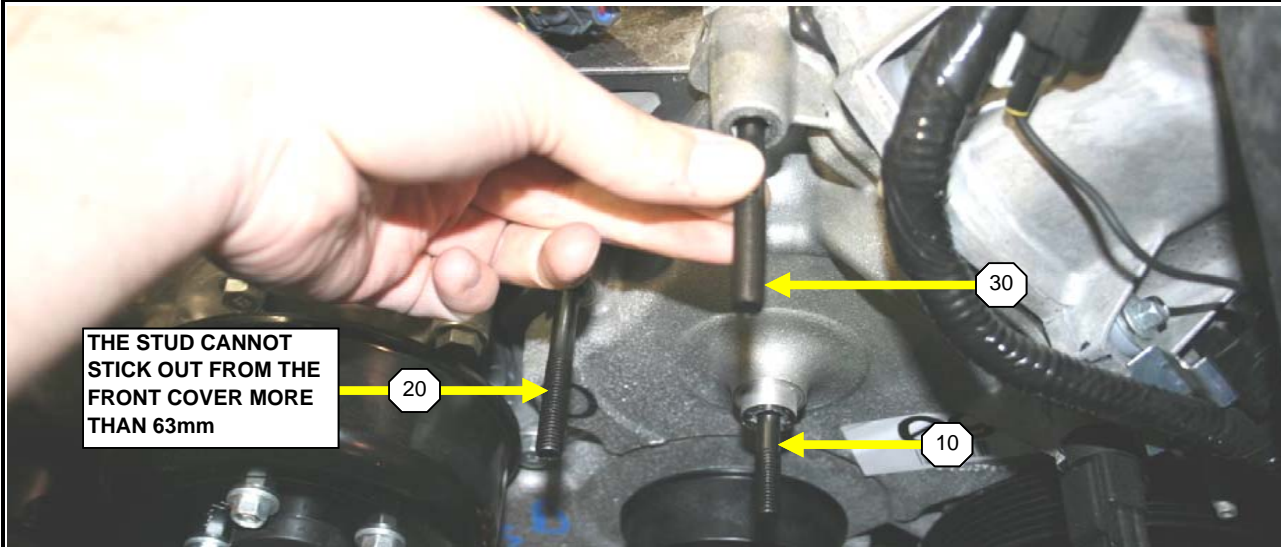

10 Apply a dab of red Loctite to the 65mm stud (A), and thread into the top right idler pulley boss.

20 Apply a dab of red Loctite to the 110mm unequal threaded stud (B), and thread the short end into the front cover bolt hole located to the upper left of the top right idler pulley boss.

NOTICE: The exposed portion of the 110mm equal thread stud cannot exceed 63mm in length past the face of the front cover. If the stud sticks out farther than 63mm, remove that portion of the stud that exceeds the length requirement, and tap the threads. Repeat **OPERATION 20**.

30 Apply a dab of red Loctite to the 110mm equal thread stud (C), and thread into the front cover bolt hole located directly above the top right idler pulley boss. Thread the stud in until it hits the end of the threads in the engine block.

40 Slip the new smooth idler pulley (D) over the top right idler boss.

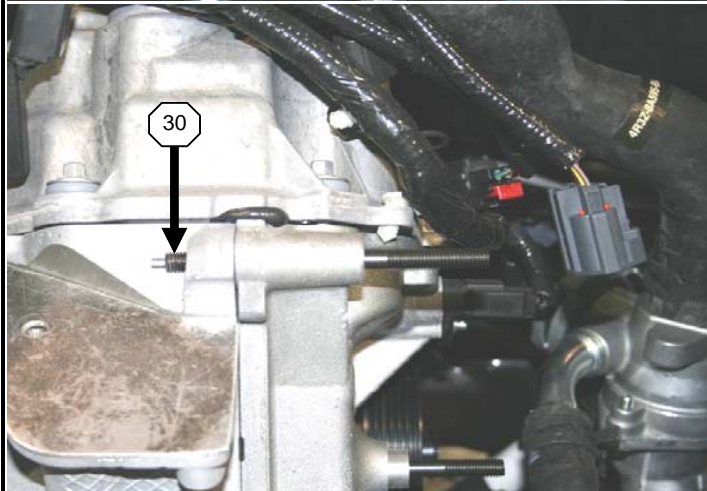

ITEM	PART NUMBER	QTY.	DESCRIPTION
A	00-9002-C110900	1	Stud Black M8x65mm
B	00-9002-C110890	1	Stud Black M8x110mm, Unequal
C	00-2002-C100910	1	Stud Black M8x110mm
D	178-428	1	Alternator Idler Pulley

NOTES:

TORQUE



PROCESS
INSTALL ALTERNATOR BRACKET AND IDLER PULLEY

PAGE

TORQUE

ITEM

OPERATION

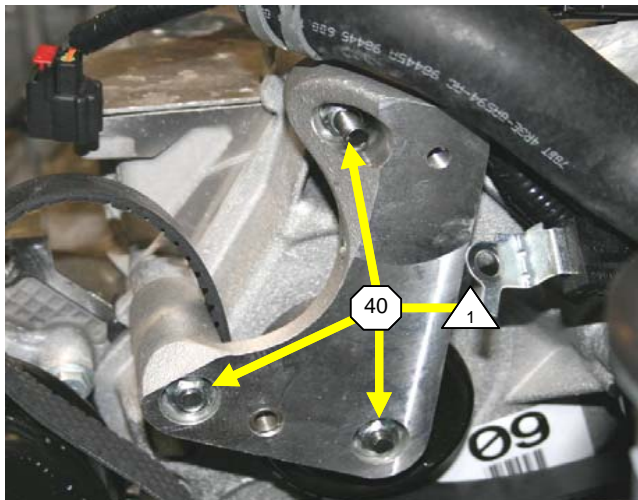
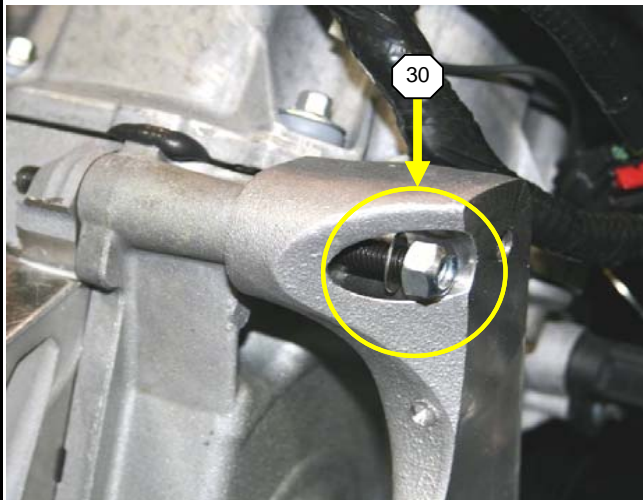
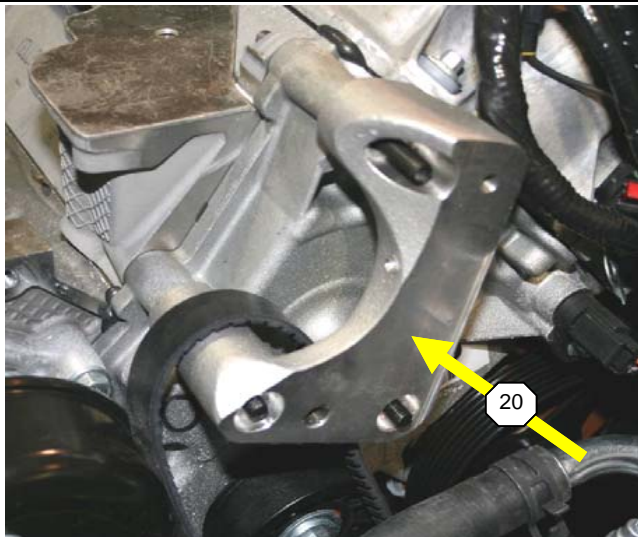

10 Retrieve the alternator bracket (A) and the serpentine belt (B). Loop the belt around the alternator bracket as shown.

20 Slide the alternator bracket and serpentine belt over the three studs installed on **Page 41-1**. The Bracket should be orientated as shown.

30 Retrieve 3 washers (C) and slide 1 over each stud once the alternator bracket is in place. Retrieve the three 13mm nuts (D), and add a dab of red Loctite to the threads of each nut. Thread 1 nut onto each stud after applying the Loctite.

40 Tighten each nut to **18 Lb-ft +/- 2.7 Lb-ft** with a torque wrench.

ITEM	PART NUMBER	QTY.	DESCRIPTION
A	06-1604-C09864	1	Alternator Mount Machined
B	00-1604-C11170*	1	Goodyear Gatorback 109.0"
C	00-9004-C15732*	3	Washer 5/16" Alternator Mount
D	00-9003-C15727*	3	Nut M8 X 1.25 Dist Thrd Locknut

NOTES:

TORQUE

1 18 +/- 2.7 Lb-ft



PROCESS
INSTALL ALTERNATOR BRACKET AND IDLER PULLEY

PAGE

TORQUE

ITEM

OPERATION

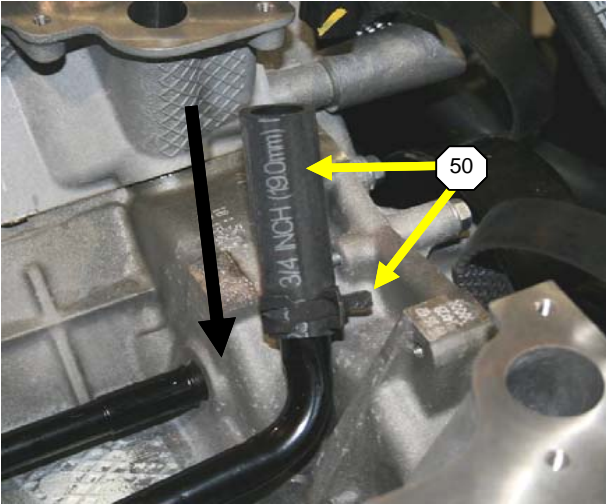
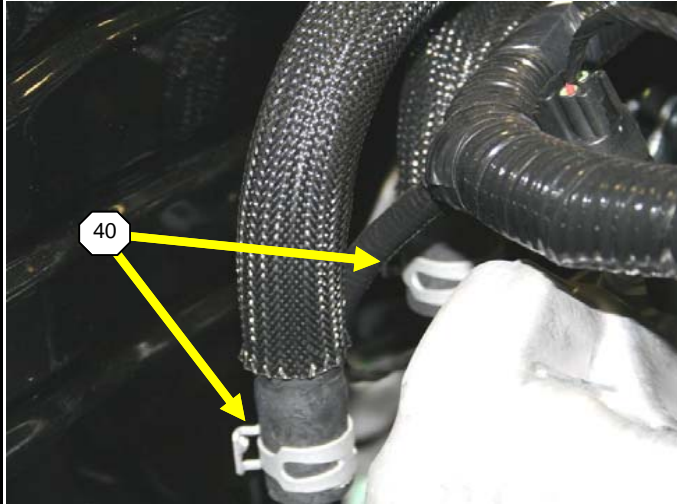
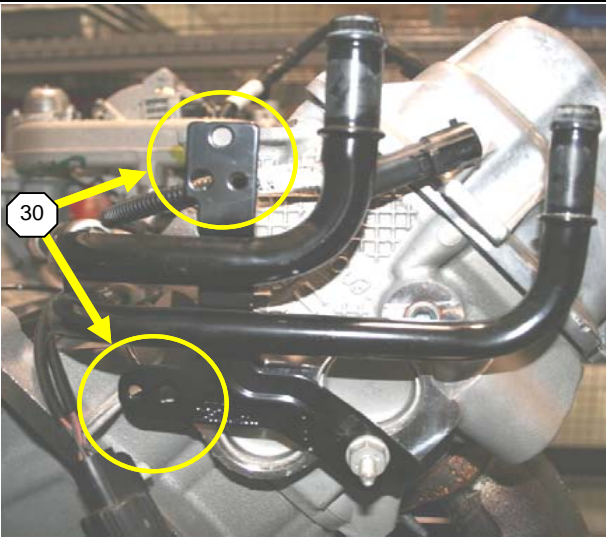
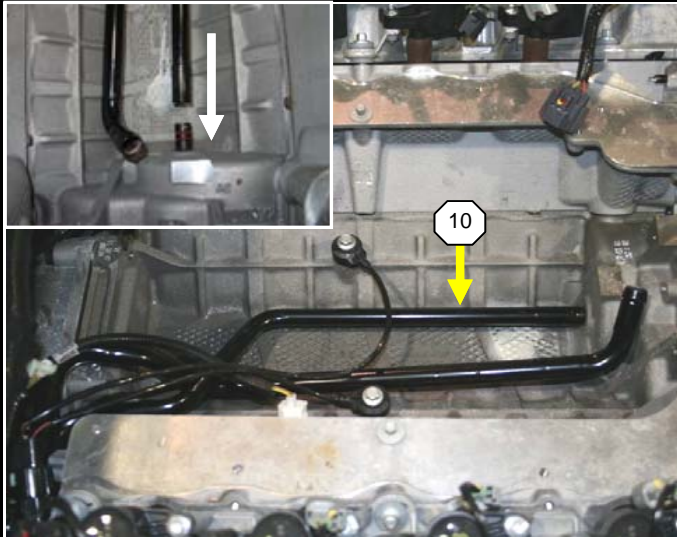

- 10 Retrieve the new water tube assembly (A) and set it into the valley on the top of the engine. Slide the straight portion of the water tube onto the coolant fitting at the front of the engine block.
- 20 Re-install the 13mm water tube stud bolt by inserting it through the mounting tab in the water tube assembly, and threading it into the passenger (RH) head. Tighten the bolt to 91 Lb-in +/- 13.6 Lb-in with a torque wrench.
- 30 Attach the 2 electrical connectors back into the water tube assembly.
- 40 Re-install the 2 heater core hoses onto the water tube assembly. Slide each hose to the stop, and then re-install the tension clamps (1 per hose).
- 50 Retrieve a 3" piece of rubber coolant hose (B) and install it onto the up-turned end of the water tube assembly (at the front of the engine block). Make sure the hose and clamp (C) are properly seated.

ITEM	PART NUMBER	QTY.	DESCRIPTION
A	06-2003-C09925	1	Water Tube 05 Mustang
B	069-950	3"	3/4" Heater Hose
C	00-2003-C10068*	1	3/4" Hose Clamp

NOTES:

TORQUE		
1	91 +/- 13.6 Lb-in	
PROCESS		INSTALL WATER TUBE ASSEMBLY
		PAGE
		56

TORQUE

ITEM

OPERATION

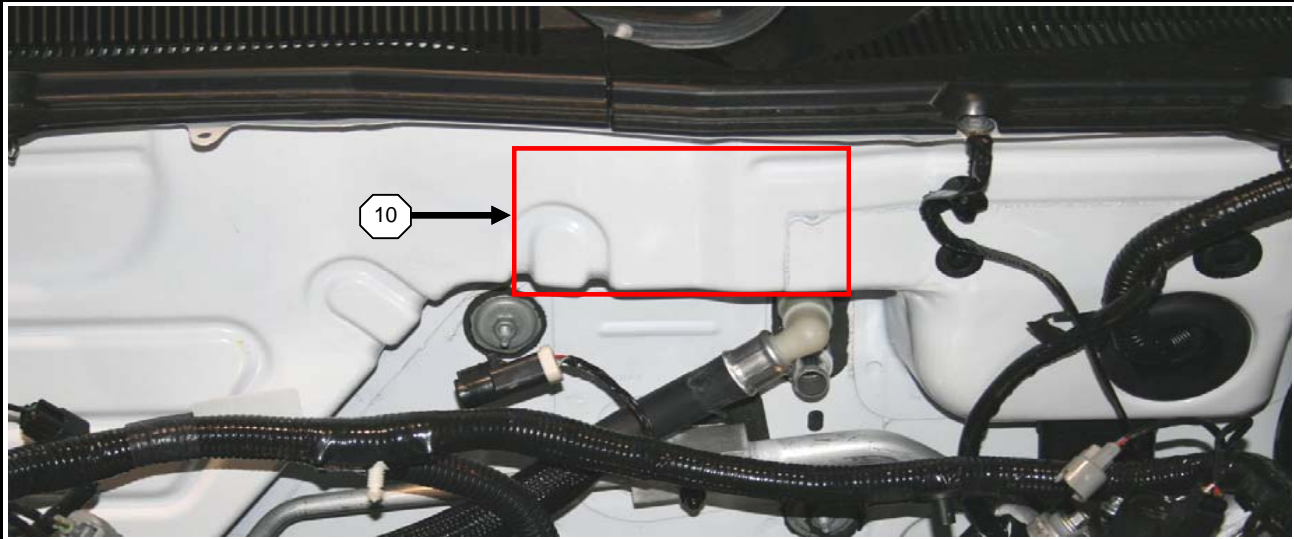

10 Use a plastic mallet to flatten the bulkhead in the section highlighted.

20 After the supercharger is lowered onto the motor, measure the clearance between the supercharger assembly and engine compartment bulkhead.

TOLERANCE

Minimum 3mm - Between bulkhead and supercharger

30 Measure the clearance between the top of the supercharger assembly and the lip (cowl) protruding from the top of the bulkhead (just below the cowl trim). The cowl lip can be bent upward to create room as needed.

TOLERANCE

Minimum 5mm - Between cowl and supercharger

NOTICE: OPERATION 20 & 30 cannot be completed until after the supercharger assembly is installed. It is stated on this page to represent how much room needs to be made to accommodate the supercharger.

ITEM	PART NUMBER	QTY.	DESCRIPTION

NOTES:

TORQUE



PROCESS
MODIFY THE ENGINE COMPARTMENT BULKHEAD TO ACCOMMODATE THE SUPERCHARGER ASSEMBLY

PAGE
 57

TORQUE

ITEM

OPERATION

10 LH SIDE SHOWN - RH SIDE TYPICAL

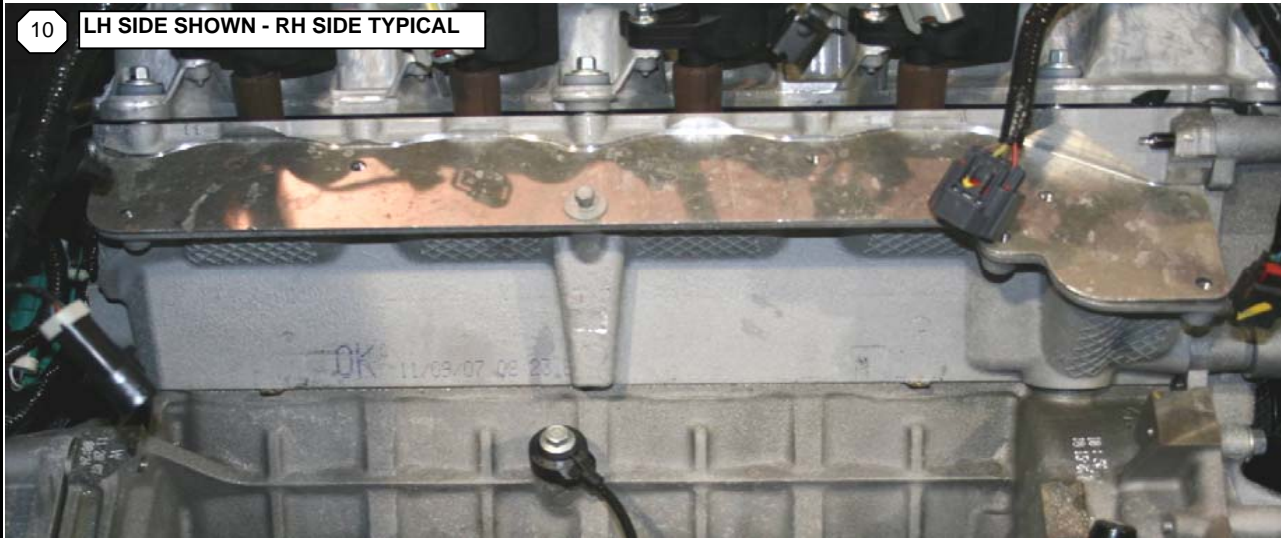

LH SIDE SHOWN - RH SIDE TYPICAL

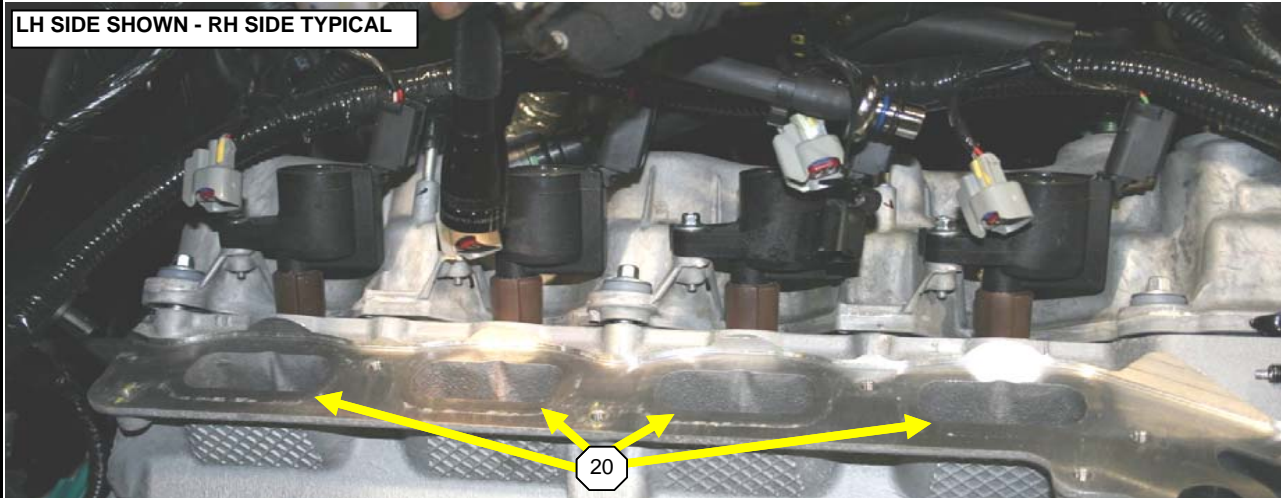

10 Remove the Masking tape covering the head ports.

20 Look down inside each intake port with a flash light. Look for fasteners, plastic caps, or any other foreign debris. While looking in each port, insert a mechanics magnet into each port to pick up any metallic debris that might be present..

30 Clean the top of each head (where the supercharger will sit), with glass cleaner and a lint free cotton rag to clean off any dirt or residue on the head.

ITEM	PART NUMBER	QTY.	DESCRIPTION

NOTES:

TORQUE



PROCESS PAGE

INSPECT HEAD PORTS

TORQUE

ITEM

OPERATION

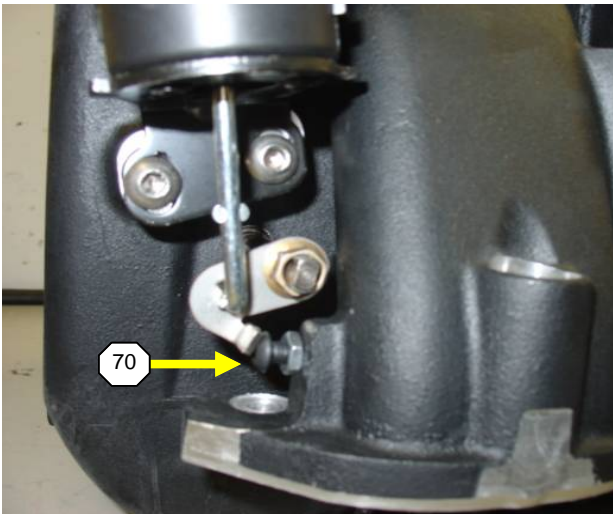
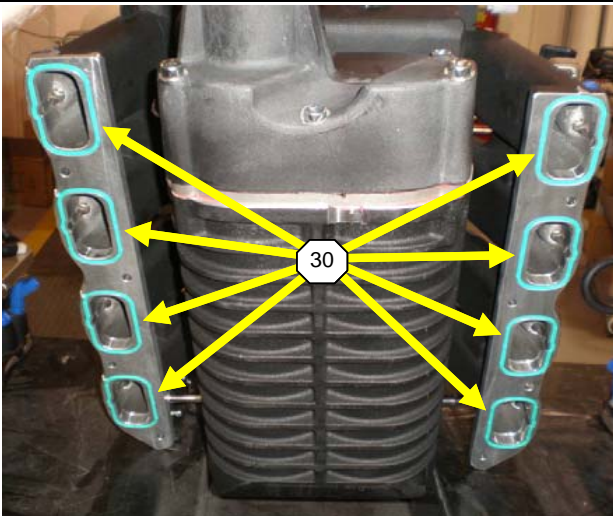
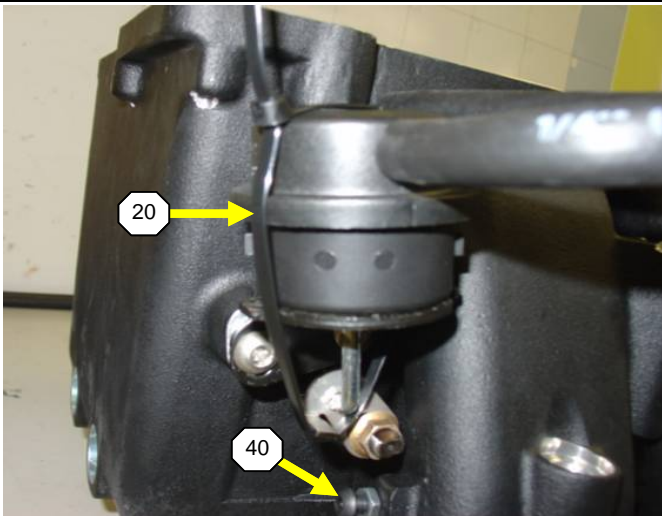

- 10 Retrieve the supercharger assembly (A).
- 20 With a large zip tie (B), fasten the bypass actuator arm up into the bypass valve.
- 30 **2005 to 2008 MODEL:** Inspect the 8 gaskets that were removed from the stock intake manifold on **Page 16**. Install each gasket into the supercharger (make sure the gaskets are fully seated).
NOTICE: If the gaskets show signs of wear or deterioration, they will need to be replaced.
2009 MODEL: This kit comes with 8 new intake manifold gaskets (C) (due to the different design of the '09 manifold). Install each gasket into the supercharger (make sure the gaskets are fully seated).
- 40 Remove the bypass stop screw from the supercharger assembly.
NOTICE: DO NOT change the position of the nut on the bypass screw. It is a pre-determined stop for the bypass valve arm.
- 50 Do a last minute check of the assembly. Verify that the fuel rail with correct injectors are installed and that all 8 manifold gaskets are in place and properly seated (**OPERATION 30**).
- 60 Slowly lower the supercharger assembly onto the top of the engine. Lift up on the front of the assembly as it is lowered to keep the nose assembly from getting damaged.
- 70 Re-install the bypass stop screw until the nut attached to the screw contacts the assembly casting. Then cut the large zip tie.

ITEM	PART NUMBER	QTY.	DESCRIPTION
A	00-1607-B19330	1	Supercharger Assy, Series VI.5
B	069-703	1	14" Zip Tie
C	00-1607-C14616*	8	Gasket, Intake Manifold To Head

NOTES:

TORQUE			
		PROCESS	PAGE
		INSTALL SUPERCHARGER	59

TORQUE

ITEM

OPERATION

20

1

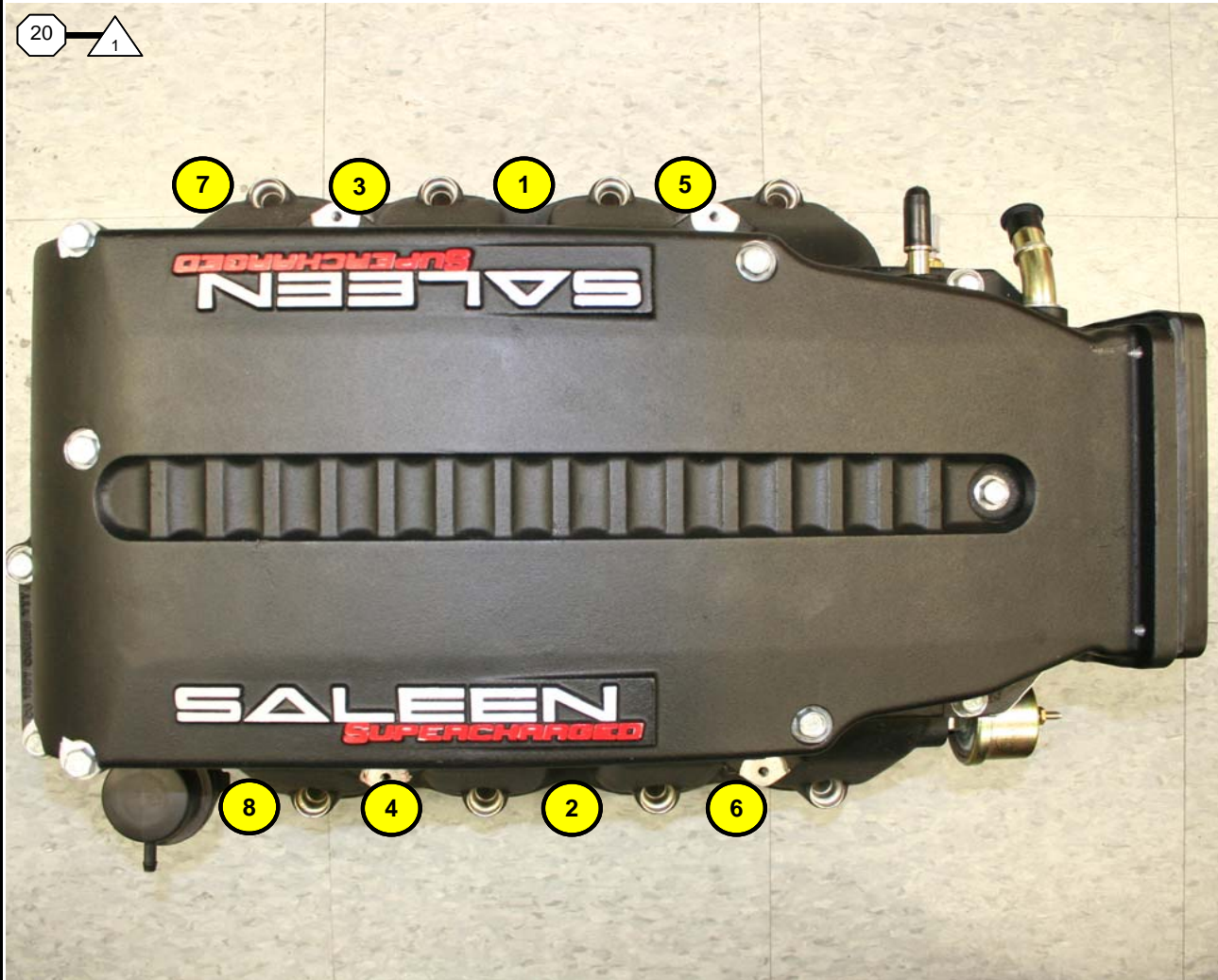

10

Retrieve the 8 bolts (A) required to fasten the supercharger assembly to the motor. Hand start each bolt, but do not tighten the bolts. Once completed, pull the supercharger assembly as far forward as the hand started bolts will allow.

20

Tighten each supercharger assembly mounting bolt to **91 Lb-in +/- 13.6 Lb-in** with a torque wrench. Make sure to torque the SC assembly in the following torque order shown.

ITEM	PART NUMBER	QTY.	DESCRIPTION
A	00-9001-C10141*	8	Capscrw Hex M6x1.0mm 25mm

NOTES:

TORQUE			PAGE
1	91 +/- 13.6 Lb-in		
		INSTALL SUPERCHARGER	

TORQUE

ITEM

OPERATION

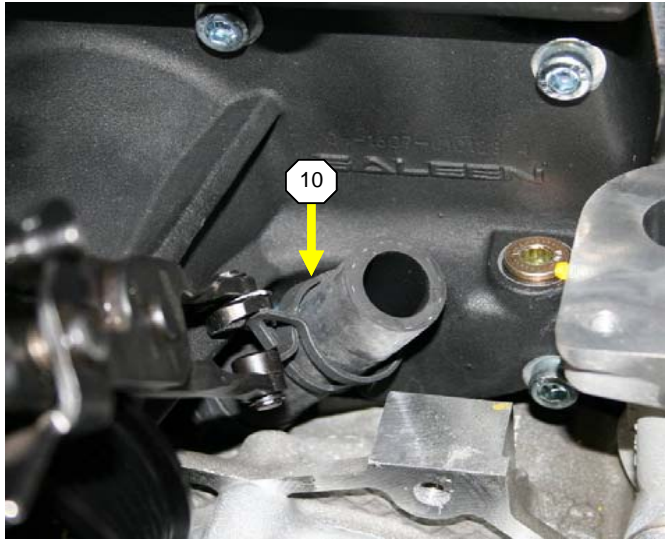

ORIENTATE THE GASKET SO THE NUB SETS INSIDE THE MACHINED NOTCH

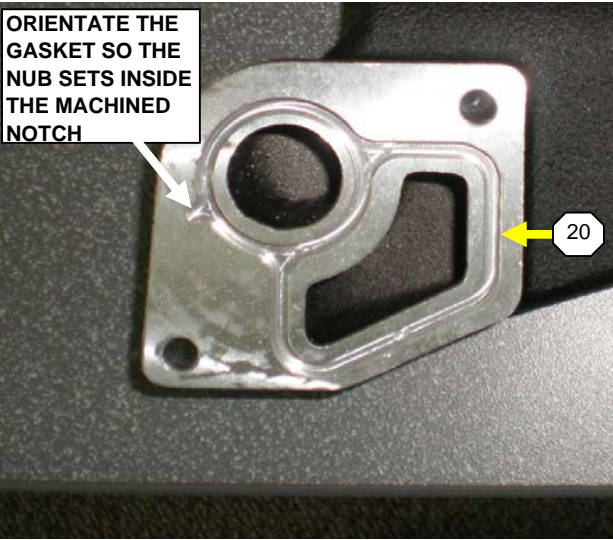

10

Install a tension clamp (A) onto the 3" section of hose coming off of the water tube. Keep the clamp tool engaged on the clamp.

20

2005 to 2006 Vehicles: Retrieve the water cross over and install the new gasket (B). Install it onto the bottom of the crossover. Make sure the gasket is fully seated.

2007 to 2009 Vehicles: Retrieve the water cross over and install the take-off gasket onto the bottom of the crossover. Make sure the gasket is fully seated.

30

Then retrieve the round take-off gasket from the old crossover, and install it on the other side of the new water crossover. Make sure the gasket is fully seated.

40

Set the crossover in place in front of the super charger assembly. Make sure the brass fitting on the bottom of the crossover is inserted into the 3" hose section.

NOTICE: Test fit the crossover before bolting it down on the next page. The brass fitting may have to be turned so that the hose in OPERATION 10 does not make hard contact to the engine block.

ITEM	PART NUMBER	QTY.	DESCRIPTION
A	00-2003-C100680	1	3/4" Hose Clamp
B	06-2003-C143820	1	Gasket, Water Crossover, Driver

NOTES:

TORQUE



PROCESS PAGE

INSTALL WATER CROSS OVER

TORQUE

ITEM

OPERATION

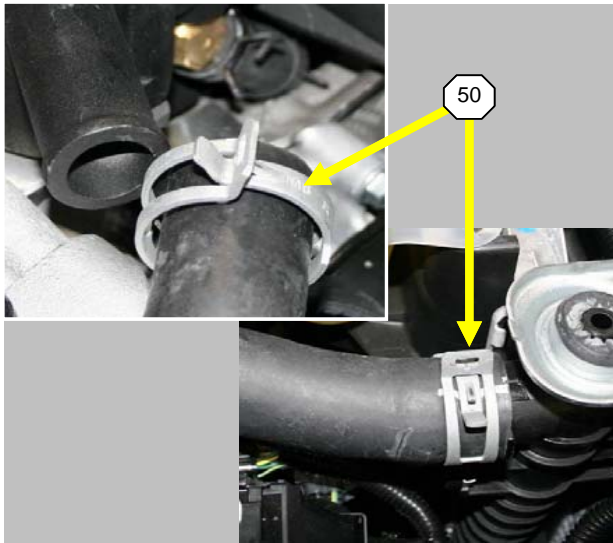
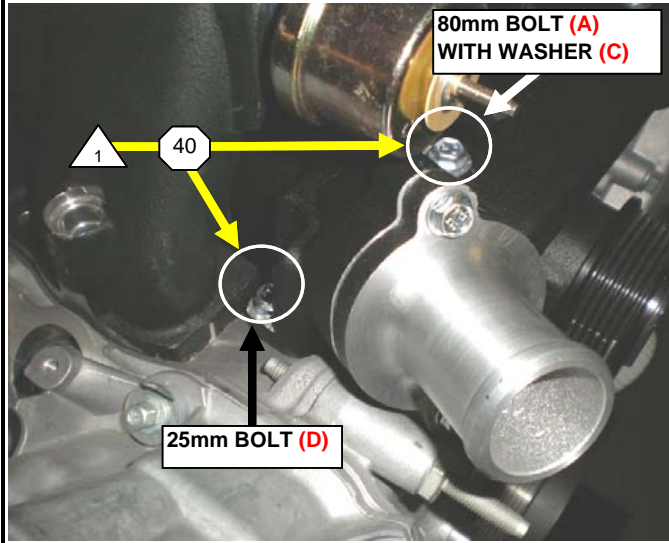
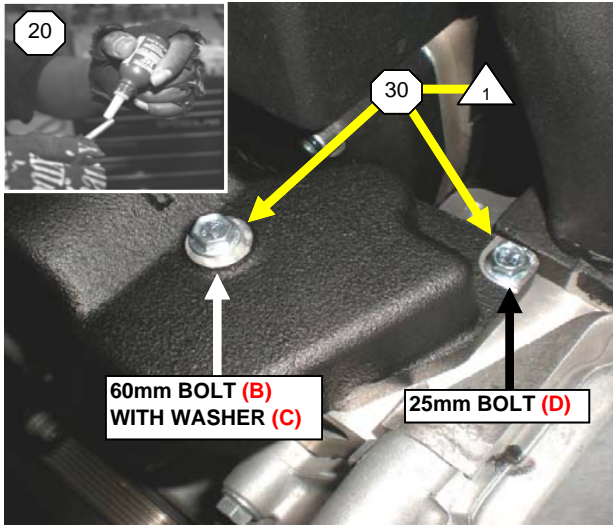
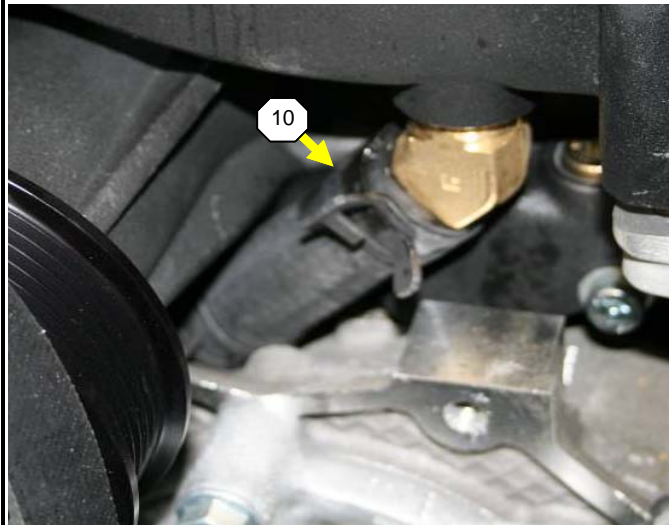

- 10 Make sure the hose fully engages the brass fitting on the bottom of the crossover. The hose should be all the way against the fitting stop. Install the clamp as shown.
- 20 Apply blue Loctite to the threads of 4 water crossover bolts (one 80mm bolt (A), one 60mm bolt (B), and 2 shorter 25mm bolts (C)).
- 30 Slide a M6 washer (C) onto the medium sized 60mm bolt (B), and install the bolt into the driver (LH) side mounting hole of the the water crossover. Then install the small 25mm bolt (D) into the back mounting hole on the driver (LH) side of the crossover. Tighten each bolt to **91 Lb-in +/- 13.6 Lb-in** with a torque wrench.
- 40 Slide the remaining M6 washer (C) onto the large sized 80mm bolt (A), and install it into the passenger (RH) side mounting hole of the the water crossover. Then install the small 25mm bolt (D) into the back mounting hole on the passenger (RH) side of the crossover. Tighten each bolt to **91 Lb-in +/- 13.6 Lb-in** with a torque wrench.
- 50 Retrieve the upper radiator hose (E), and install the two take-off clamps. Slide the one end of the hose over the water crossover outlet, and the other end over the radiator inlet. Set each clamp by using a flat blade screwdriver. Release the clamps and make sure both clamps are fully engaged.

ITEM	PART NUMBER	QTY.	DESCRIPTION
A	00-9001-C19336	1	Capscrw Hex M6x1.0mm 80mm
B	00-9001-C19335	1	Capcrew Hex M6x1.0mm 60mm
C	00-9004-C19337	2	M6 Washer
D	00-9001-C101410	2	Capcrew Hex M6x1.0mm 25mm
E	06-2003-C14379	1	Hose, Upper Rad, Passenger

NOTES:

TORQUE

1 91 +/- 13.6 Lb-in



PROCESS PAGE

INSTALL WATER CROSS OVER

TORQUE

ITEM

OPERATION

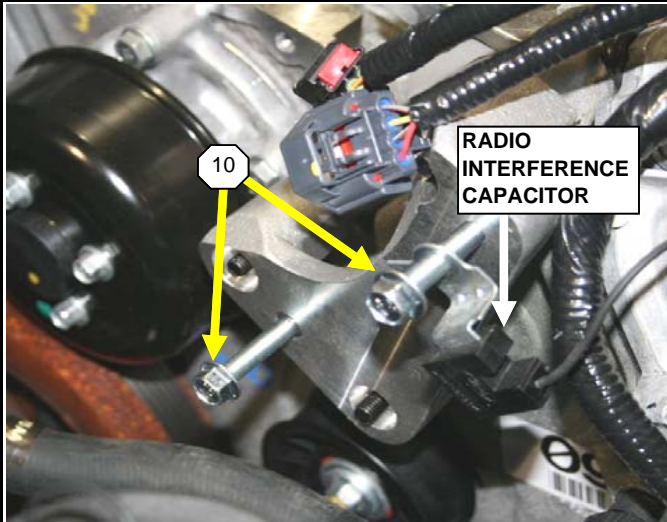

RADIO INTERFERENCE CAPACITOR

10



20

ALTERNATOR HARNESS STAND-OFF - 2005 to 2008 MODELS

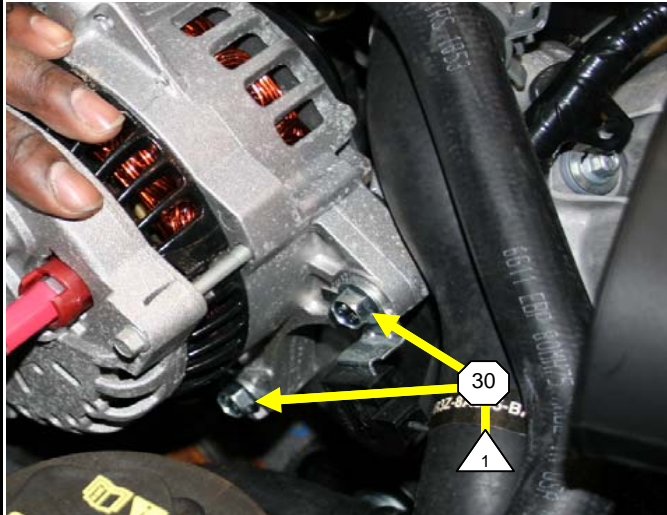

30

1

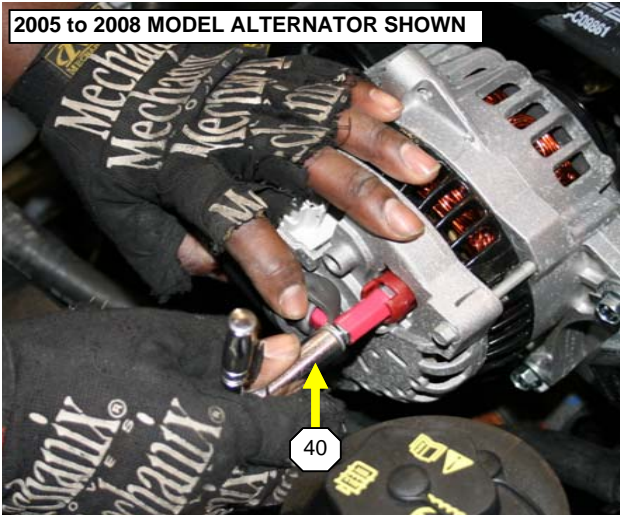

2005 to 2008 MODEL ALTERNATOR SHOWN

40

NOTICE: The 2005 to 2008 alternator is shown in the photos at the left. The 2009 alternator installation is similar. If the vehicle is a 2009 model, it will not have a harness stand-off.

10 Apply red Loctite to the threads of two 12mm bolts (A), and hand start each bolt into the face of the alternator bracket. Make sure to feed the top bolt through the radio interference capacitor before threading it into the alternator bracket.

20 Retrieve the alternator with the new pulley installed on **Pages 30AB to 31AB or 30C to 31C**. Slip the alternator onto the hand started bolts protruding from the alternator bracket. Make sure the interference capacitor stays between the alternator and the head of the bolt.

30 Once the alternator is in place, run down and tighten each alternator mounting bolt to **18 Lb-ft +/- 2.7 Lb-ft** with a torque wrench.

40 **2005 to 2008 Models:** Remove the 10mm nut at the end of the alternator wire stand-off and set aside.

2009 Models: Remove the 13mm nut at the back of the alternator and set aside.

ITEM	PART NUMBER	QTY.	DESCRIPTION
A	00-9001-C106650	2	Capscrw Hex M8x1.25mm 40mm

NOTES:

TORQUE

1 18 +/- 2.7 Lb-ft



PROCESS PAGE

INSTALL ALTERNATOR

TORQUE

ITEM

OPERATION

2005 to 2008 MODELS

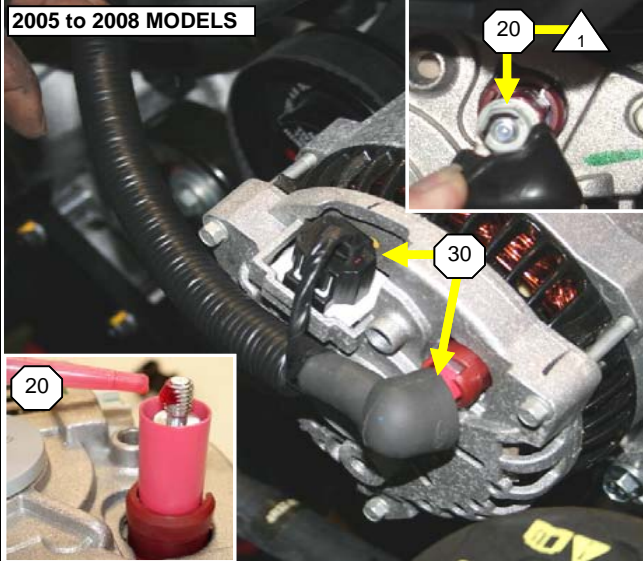

2009 MODELS

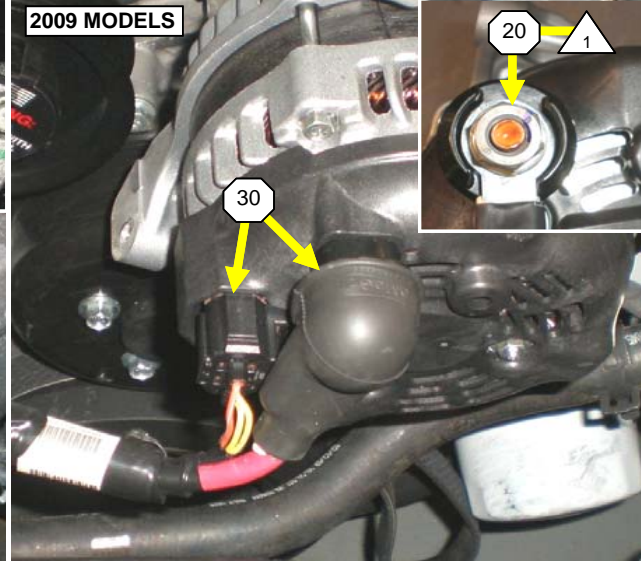

2005 to 2008 MODEL HARNESS SHOWN - 2009 MODEL HARNESS TYPICAL

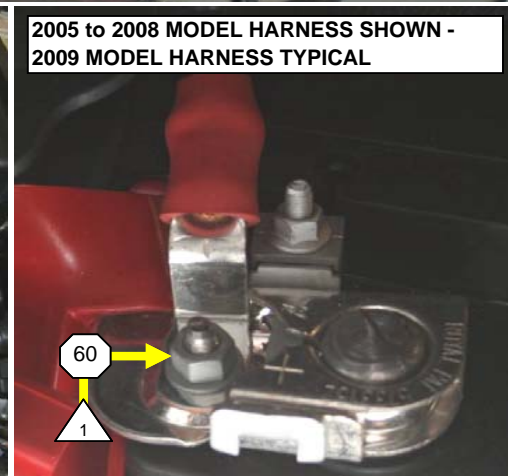

NOTICE: There are slight differences in the installation and routing of the modified alternator harness depending on model year. Pay attention to the different photos and instructions for each model year vehicle.

10 Retrieve the alternator harness.

20 **2005 to 2008 Models:** Apply a dab of red Loctite onto the threaded end of the alternator stand-off. Then slip the ring terminal end of the alternator harness (that is covered by a grey boot) over the end of the stand-off. Re-install the 10mm alternator stand-off nut and torque it to **71 Lb-in +/- 10.6 Lb-in** with a torque wrench.

2009 Models: Apply a dab of red Loctite onto the threaded end of the alternator stud. Then slip the ring terminal end of the alternator harness (that is covered by a grey boot) over the end of the alternator stud. Re-install the 13mm alternator nut and torque it to **71 Lb-in +/- 10.6 Lb-in** with a torque wrench.

30 Place the grey boot of the alternator harness over the mounting nut and plug in the electrical connector. Make sure the connector is fully engaged.

40 Clip the rest of the alternator harness into place. The 2 forward-most retaining clips get pressed onto the fuel rail stud bolts, and the last retainer (tree clip) gets clipped into a sheet metal tab protruding from the bulkhead.

50 Connect the alternator harness signal wire connector into the main engine harness. Make sure the connector is fully engaged.

NOTICE: For 2009 Models, The connector on the main engine harness will need to be relocated forward on the engine harness to reach the alternator harness connector.

60 Connect the end of the alternator harness to the positive battery cable clamp. Remove the 10mm nut, slip the ring terminal over the stud on the clamp, and re-install the nut. Tighten the nut to **71 Lb-in +/- 10.6 Lb-in** with a torque wrench.

NOTES:

TORQUE

1 71 +/- 10.6 Lb-in



PROCESS PAGE

INSTALL ALTERNATOR HARNESS

10

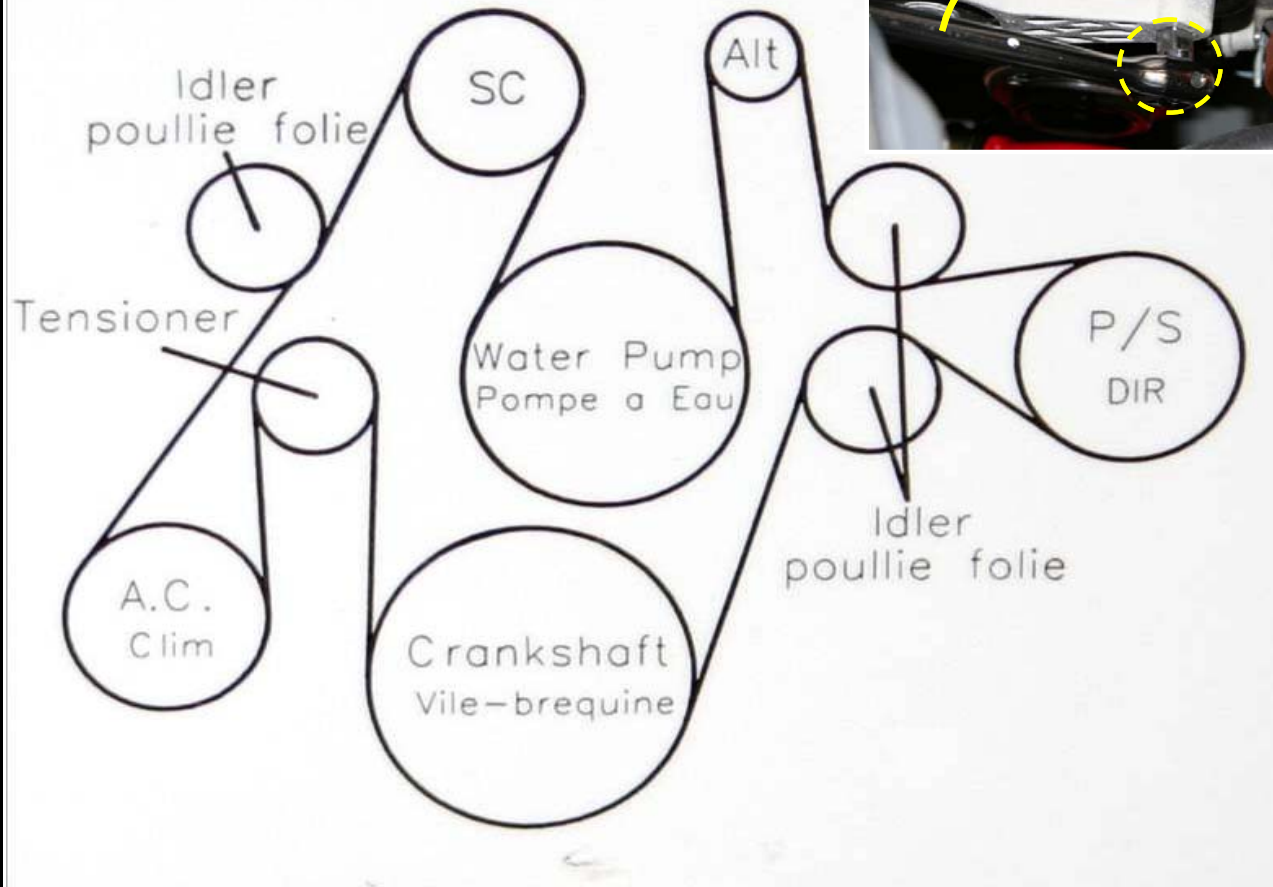

10

Route the belt (A) as shown in the belt routing decal, but leave the belt off of the water pump pulley (It is easier to slide the belt on there last).

20

Use a 1/2" drive breaker bar to relieve the tension on the tensioner by pulling on the bar clock-wise..

30

Slide the serpentine belt onto the water pump pulley.

40

Once the belt is seated on the water pump pulley, release the belt tensioner and verify that the belt is routed correctly, sits straight on all pulleys, and is properly seated on all pulleys.

ITEM	PART NUMBER	QTY.	DESCRIPTION
A	00-1604-C111700	1	Goodyear Gatorback 109.0" 6 Rib Belt

NOTES:

TORQUE



PROCESS PAGE

ROUTE SERPENTINE BELT

TORQUE

ITEM

OPERATION

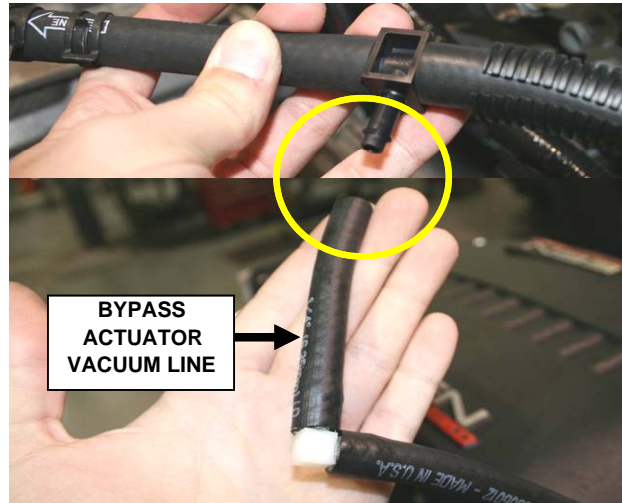
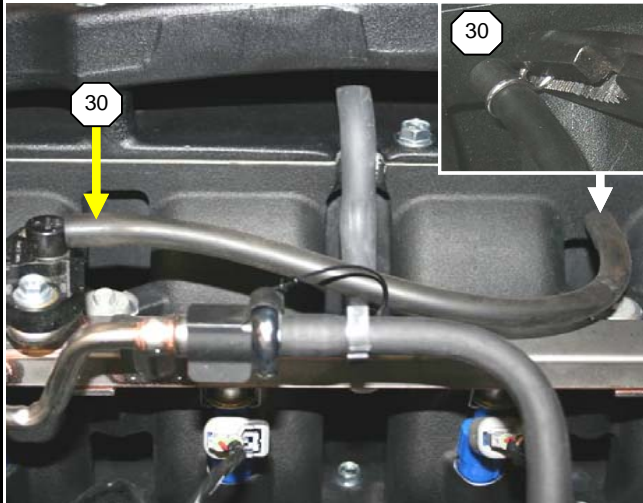
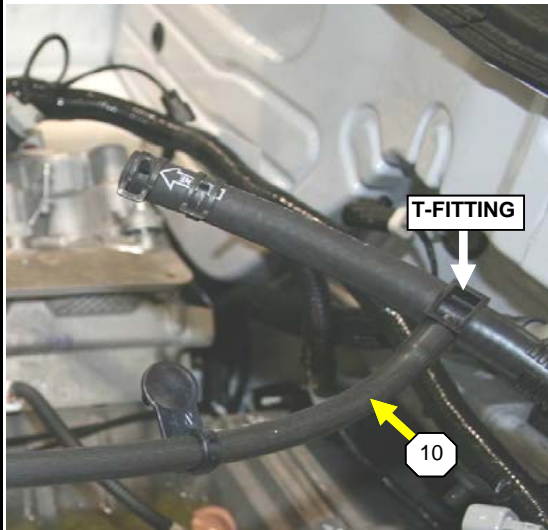

- 10 Locate the vacuum hoses connected to the brake booster. Remove the 1/4" hose from the vacuum T-fitting (that was disconnected from the fuel rail on **Page 13**).
- 20 Cut two inches off of the 1/4" line, and remove the clip .
- 30 Connect one side of the 1/4" line to the fuel pressure transducer. The other end of the hose will slide over the fitting on the back of the supercharger assembly on the driver (LH) side. The hose will be held in place with 1 wire hose clamp **(A)**.
- 40 Connect the 1/4" line coming off of the bypass actuator (hose coming off of the back of the supercharger assembly) to the T-fitting on the vacuum line (where the 1/4" hose was removed from in **OPERATION 10**).

ITEM	PART NUMBER	QTY.	DESCRIPTION
A	00-9005-C18840	1	Spring Clamp, 7/16IN SS

NOTES:

TORQUE



PROCESS PAGE

MODIFY THE ENGINE VACUUM HOSES

TORQUE

ITEM

OPERATION



- 10 Remove the brake booster side of the 3/8" vacuum line (at the T-fitting) and remove a 4 & 1/4" section (including the convoluted sleeving).
- 20 Once the 4 & 1/4" of vacuum line and convolute is removed, re-insert the 3/8" vacuum line into the T-fitting.
- 30 Take the piece of convoluted sleeving that was cut and removed in **OPERATION 10**, and slide it over the 3/8" vacuum line leading from the T-fitting to the supercharger manifold.
- 40 Slide the 3/8" vacuum line over the fitting on the rear LH corner of the supercharger assembly.

ITEM	PART NUMBER	QTY.	DESCRIPTION

NOTES:

TORQUE



PROCESS PAGE

MODIFY THE ENGINE VACUUM HOSES

TORQUE

ITEM

OPERATION

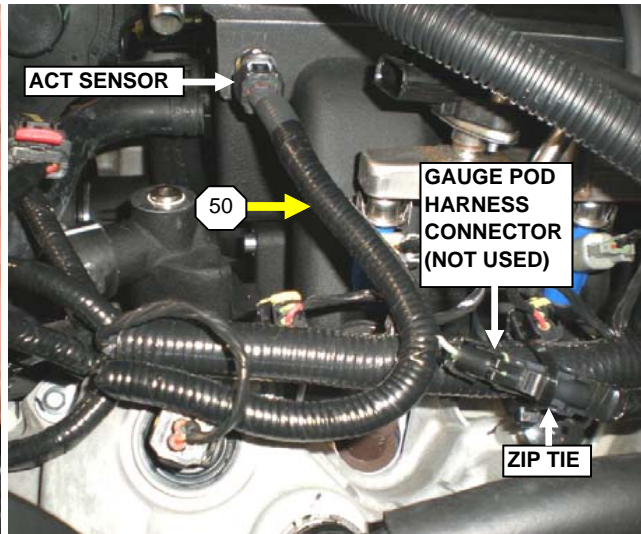
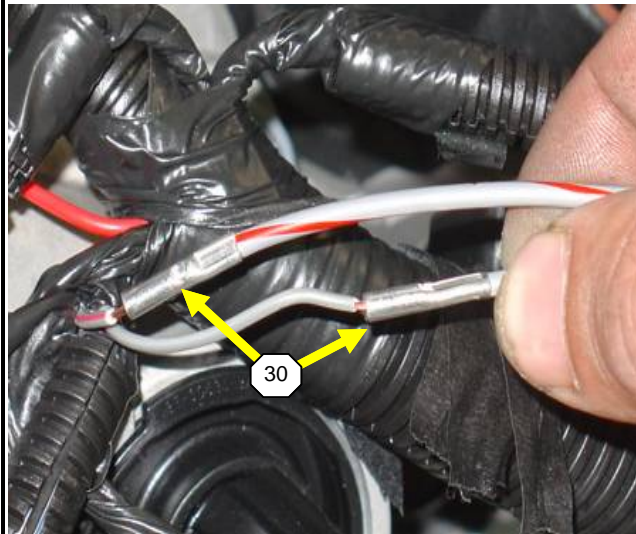
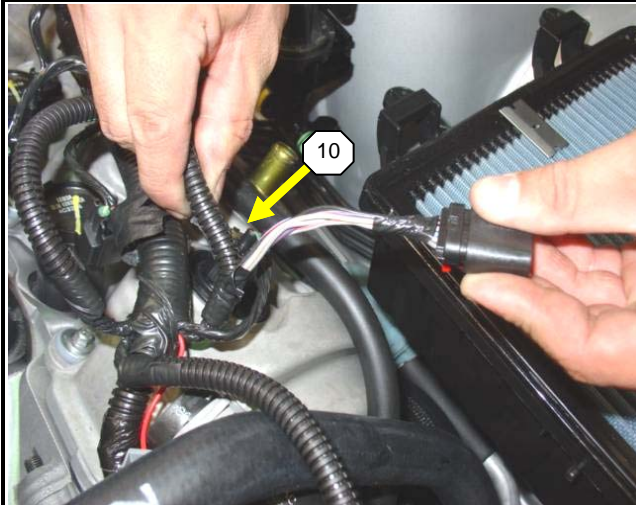

- 10 Locate the MAF connector, and peel back the convoluted sleeving to about 6" behind the connector.
- 20 Locate both the gray and gray w/red stripe wires, and cut the gray wire 4.5" behind the connector, and the gray w/ red wire 6" behind the connector.
- 30 Strip ¼" of insulation off of the harness ends of the two wires, and then slide a 1" section of 1/8" heat shrink (B) over each wire. Once the heat shrink is on each wire, slide the butt connectors (C) of the like colored wires of the ACT extension kit (A) onto the harness side of the cut wires and crimp with a compression crimp tool. Add a dab of solder to the each crimped connection.
- 40 Slide each heat shrink piece installed in OPERATION 30 over the butt splices and apply heat to seal.
- 50 Replace the convoluted sleeving that was peeled back in OPERATION 10, and secure with black electrical tape. Plug the ACT connector into the ACT sensor on the drivers side of the supercharger manifold. Secure the single pin connector that connects to a gauge pod harness (not included in this kit) with 1 zip tie (D) to the main engine harness.

ITEM	PART NUMBER	QTY.	DESCRIPTION
A	06-1704-B12563	1	Harness, ACT Connector
B	00-1704-C08921*	3"	Heat Shrink, 1/8" Black
C	00-1704-C09260*	2	Splice, 18-20 AWG Butt
D	00-9007-C10122*	1	7" Zip Tie

NOTES:

TORQUE



PROCESS

WIRE IN THE ACT HARNESS TO THE MAIN ENGINE HARNESS

PAGE

TORQUE

ITEM

OPERATION

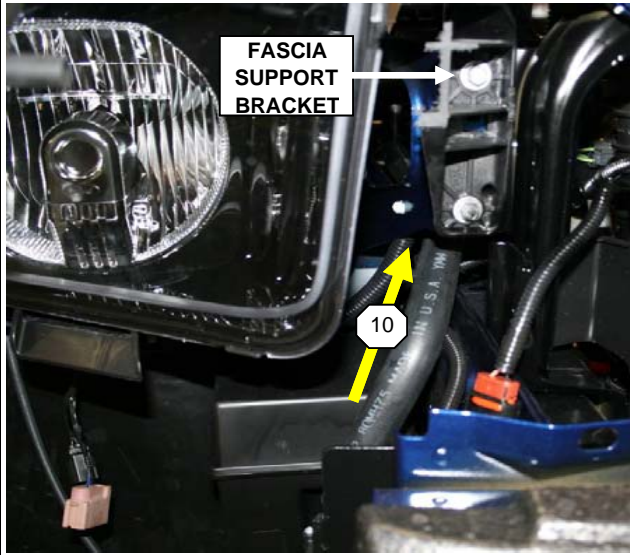

FASCIA SUPPORT BRACKET

10

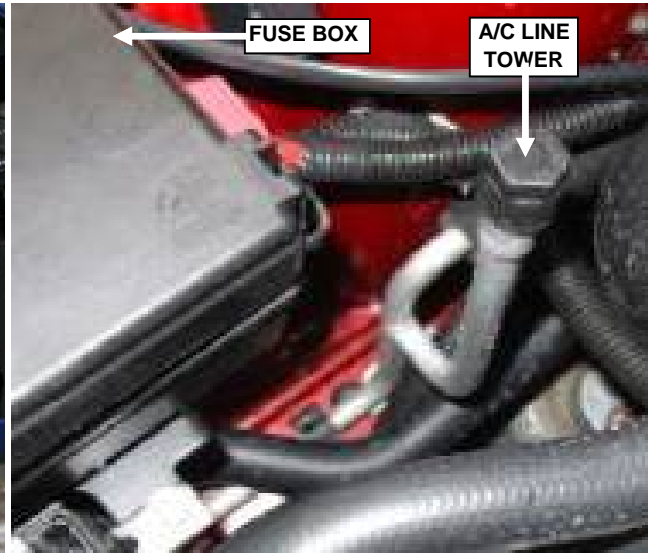

FUSE BOX

A/C LINE TOWER

10

Starting at the front of the vehicle, route the water pump to recovery tank hose (A) underneath the passenger (RH) fascia support bracket, and over the frame rail.

20

Continue routing the hose underneath the fuse box. The end of the hose should stick up in the air just behind the A/C line tower.

30

With 1 tension clamp (B), connect the hose to the intercooler water pump. The hose connects to the top fitting.

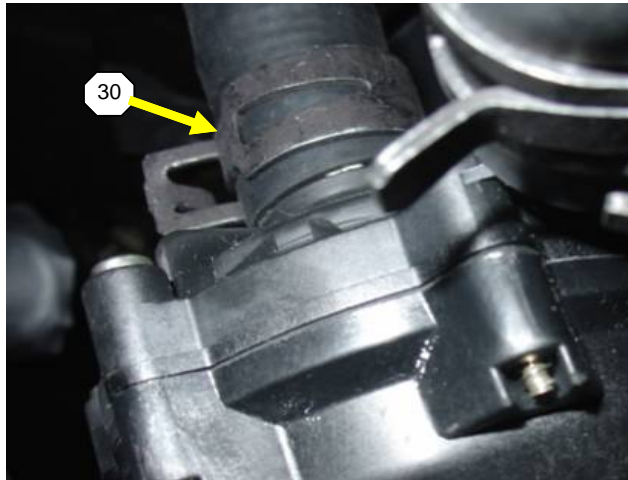

30

ITEM	PART NUMBER	QTY.	DESCRIPTION
[A]	06-2003-C09857	1	Molded Hose S/C Tank to Pump
[B]	00-2003-C10068*	1	Hose Clamp Molded Hose S/C

NOTES:

TORQUE



PROCESS PAGE

INSTALL INTERCOOLER HOSE:
WATER PUMP TO
RECOVERY TANK

TORQUE

ITEM

OPERATION

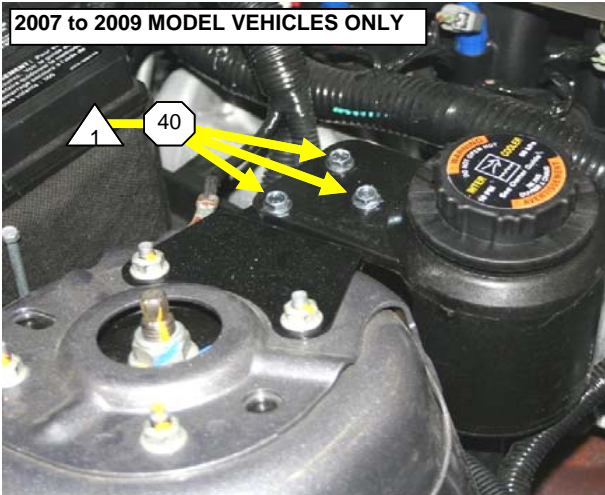
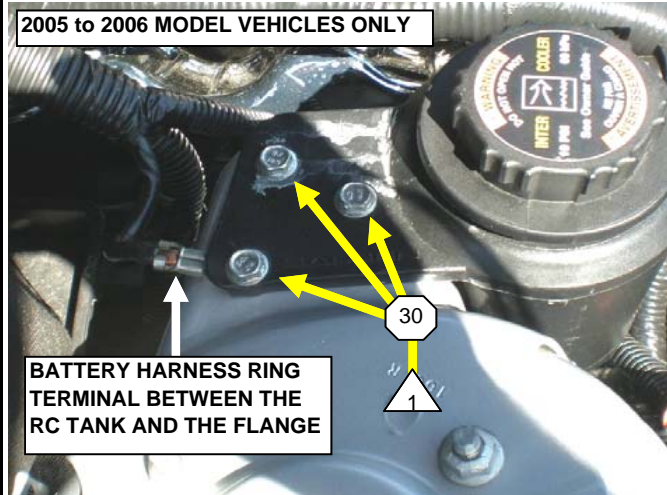

2005 to 2006 MODEL VEHICLES ONLY

2007 to 2009 MODEL VEHICLES ONLY

10

Install the intercooler water pump to recovery tank hose by inserting the hose onto the bottom nipple of the recovery tank and securing it in place with a tension clamp (A).

20

2005 to 2006 Vehicles: Locate the sheet metal flange protruding from the top of the passenger (RH) side strut tower. Remove the 10mm bolt holding the battery harness ground ring terminal to the strut tower flange. Just remove the bolt, but leave the ring terminal in place.

30

2005 to 2006 Vehicles: Set the recovery tank (B) on top of the strut tower flange (so that the tank is positioned in forward of the flange) and line up the holes. Make sure the recovery tank sits on top of the ground ring terminal. Install the three 10mm bolts (C) and torque them to **71 Lb-in +/- 10.6 Lb-in** with a torque wrench.

NOTICE: Between 2005 and 2006 Ford removed the pressed in nuts on the strut tower flange. In the 2005 to 2006 kit, 2 washer (D) and 2 Nyloc nuts (E) are included. If the pressed in nuts are missing, slip the bolts through the holes in the flange, and use the washers and nuts to secure the recovery tank. The torque remains the same as stated above.

40

2007 to 2009 Vehicles: Set the recovery tank (B) onto the recovery tank bracket (installed on [Page 48BC](#)) and line up the holes. Install the three 10mm bolts (C) and torque them to **71 Lb-in +/- 10.6 Lb-in** with a torque wrench.

ITEM	PART NUMBER	QTY.	DESCRIPTION
A	00-2003-C10068*	1	Hose Clamp Molded Hose S/C
B	06-2001-C10212	1	Tank Intercooler Recovery
C	00-9001-C10141*	3	Capscrw Hex Flng M6x1.0mm 25mm
<i>READ NOTICE BELOW OPERATION 30 CONCERNING ITEMS (D) & (E)</i>			
D	00-9004-C12007*	2	Washer, M6 ID 18MM OD, 18-8 SS
E	00-9003-C10936*	2	Nut Nyloc M6 10mm W 6mm H

NOTES:

TORQUE

1

71 +/- 10.6 Lb-in



PROCESS PAGE

INSTALL THE RECOVERY TANK

TORQUE

ITEM

OPERATION

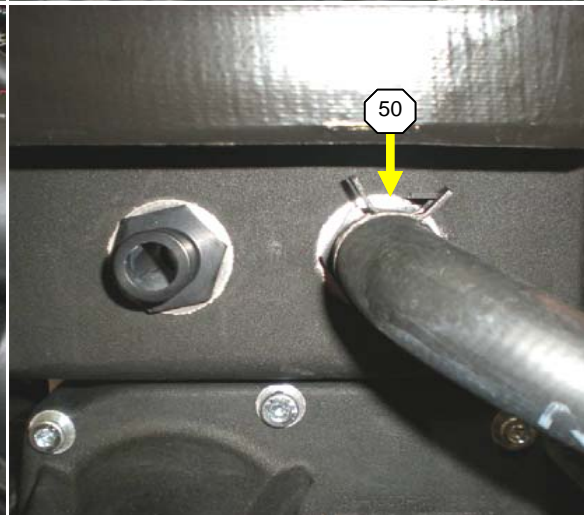
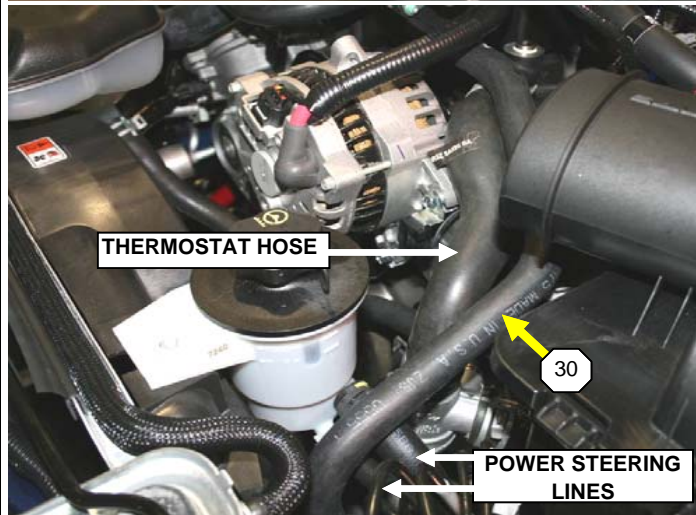
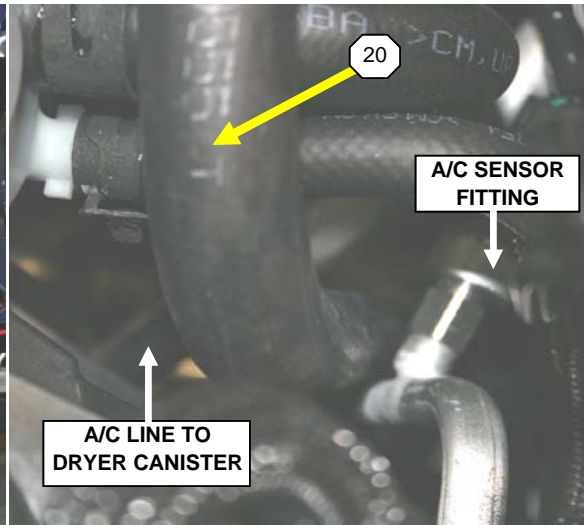
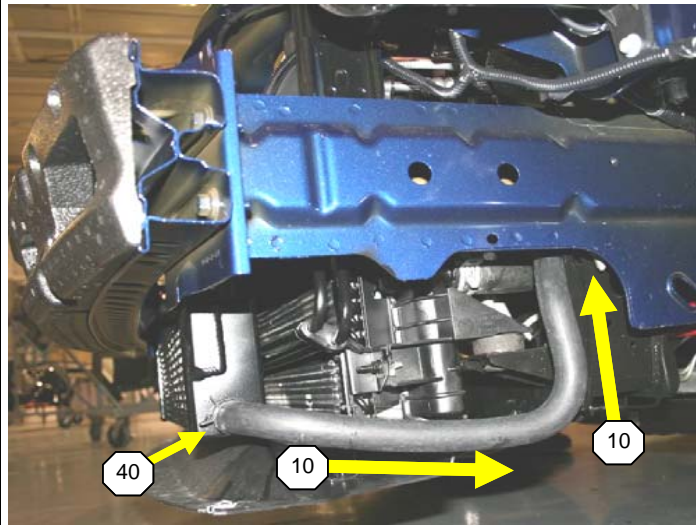

- 10 Route the heat exchanger to intercooler hose (A) around the cooling pack (towards the driver (LH) side). The hose will then proceed upward between the frame rail and the lower radiator hose.
 - 20 Route the hose upward between the A/C line heading to the dryer canister, and the A/C Line sensor fitting.
 - 30 The hose will then cross over the top of the two power steering lines exiting the reservoir. The hose will then follow the water crossover to thermostat hose.
 - 40 Connect the heat exchanger to intercooler hose with 1 tension clamp (B) at the heat exchanger.
 - 50 Connect the heat exchanger to intercooler hose with 1 tension clamp (B) at the intercooler. The hose will be installed on the driver (LH) side fitting protruding from the front of the supercharger assembly. Make sure the tabs of the clamp are facing upward.
- NOTICE:** Make sure the hose and clamps are fully seated on the fittings, and that the entire clamping area of the clamp is fully engaging the hose and fitting.

ITEM	PART NUMBER	QTY.	DESCRIPTION
A	06-2003-C09861	1	Molded Hose S/C H.E To Intercooler
B	00-2003-C100680	2	Hose Clamp Molded Hose S/C

NOTES:

TORQUE



PROCESS PAGE

INSTALL HEAT EXCHANGER TO INTERCOOLER HOSE

TORQUE

ITEM

OPERATION

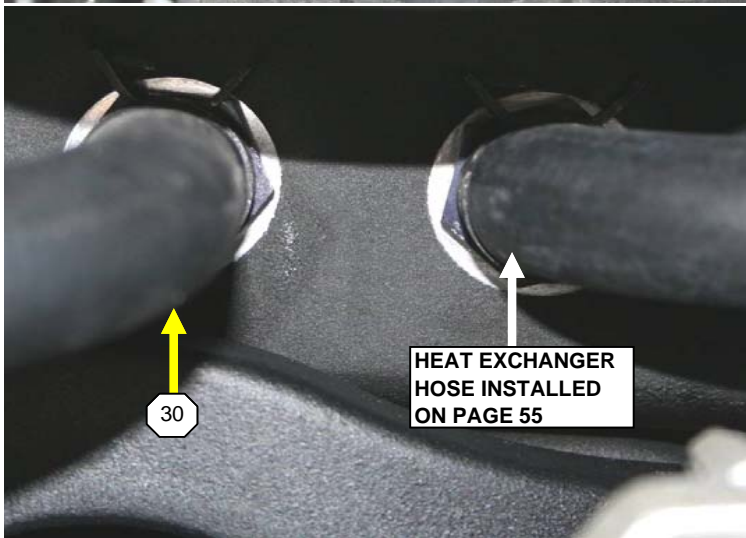
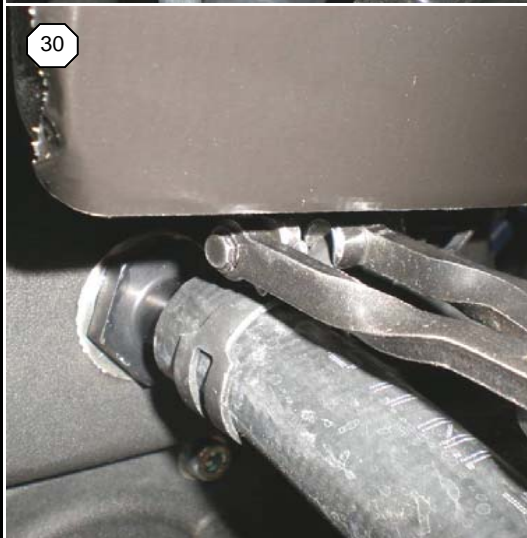
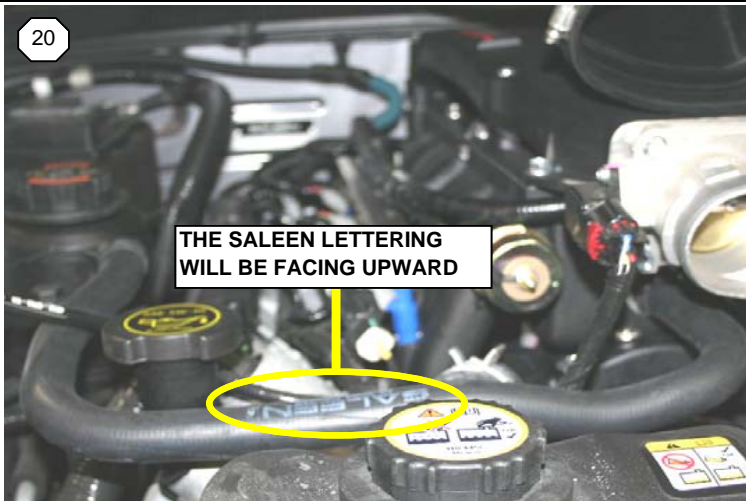

10

Retrieve the recovery tank to intercooler hose (A) and 2 hose tension clamps (B). With tension clamp pliers, slide a clamp onto each end of the hose.

20

Install the recovery tank to intercooler hose onto the recovery tank by sliding the long end of the hose over the recovery tank fitting. Orientate the hose so that the Saleen lettering is facing upward. Lastly, set the tension clamp.

30

Slide the other end of the hose over the passenger (RH) side fitting of the supercharger assembly. Use tension clamp pliers to set the clamp, and make sure the tabs of the clamp are facing upward.

NOTICE: Make sure the hose and clamps are fully seated on the fittings, and that the entire clamping area of the clamp is fully engaging the hose and fitting.

ITEM	PART NUMBER	QTY.	DESCRIPTION
A	06-2003-C09860	1	Hose, Rec Tank - Intr Cooler
B	00-2003-C100680	2	Hose Clamp

NOTES:

TORQUE



PROCESS PAGE

INSTALL RECOVERY TANK TO INTERCOOLER HOSE

▲ TORQUE

■ ITEM

⬡ OPERATION



- ⬡ 10 Remove the tape covering the intake port of the supercharger lid.
- ⬡ 20 Insert the take-off Ford throttle body gasket (removed on **Page 10**), into the groove in the front of the inlet tube. Make sure the gasket is fully seated into the groove.
- ⬡ 30 Using the four 10mm bolts (A), install the stock throttle body onto the inlet assembly. Tighten the bolts to **91 Lb-in +/- 13.6 Lb-in** with a torque wrench.

ITEM	PART NUMBER	QTY.	DESCRIPTION
A	00-9001-C101410	4	Capscrw, M6x1.0mmx25mm

NOTES:

TORQUE			PAGE
▲ 1	91 +/- 13.6 Lb-in		
		INSTALL THROTTLE BODY	

TORQUE

ITEM

OPERATION

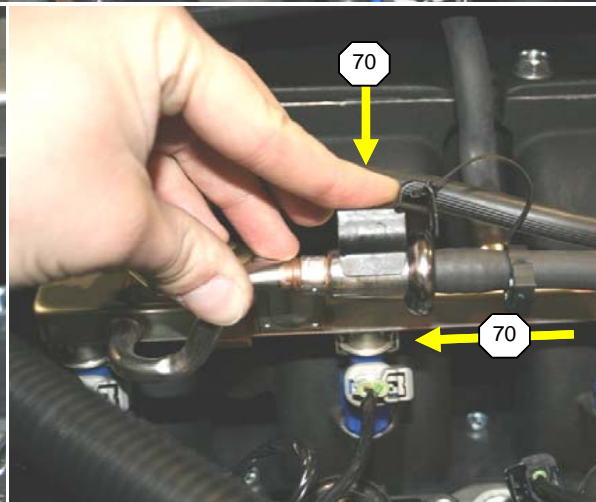
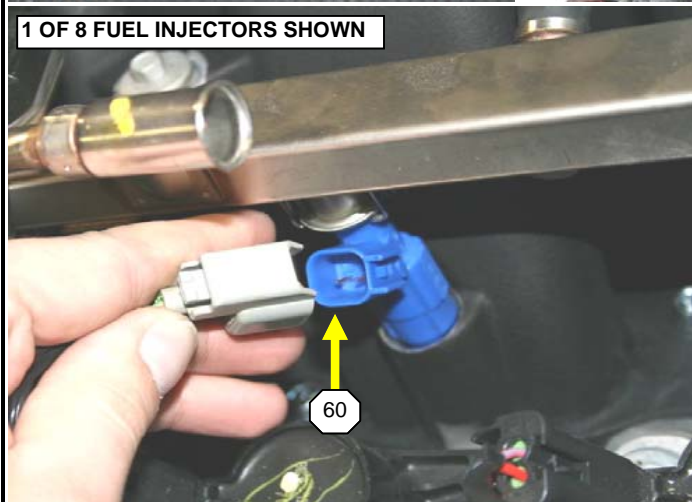
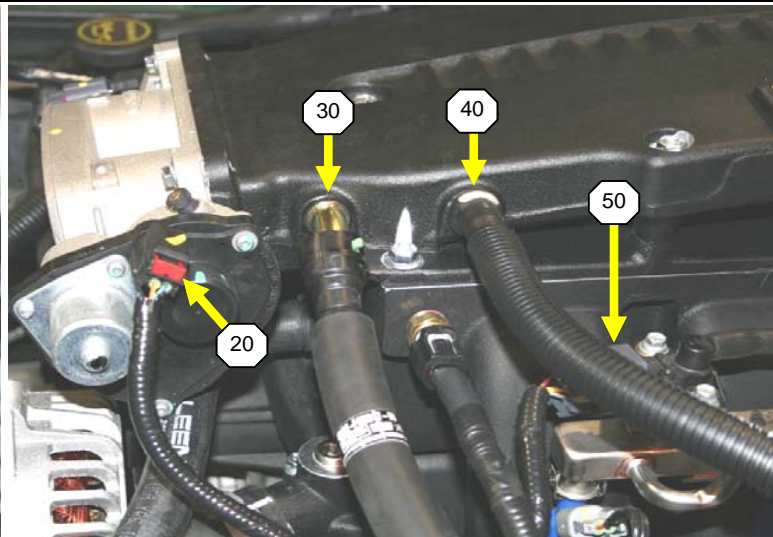
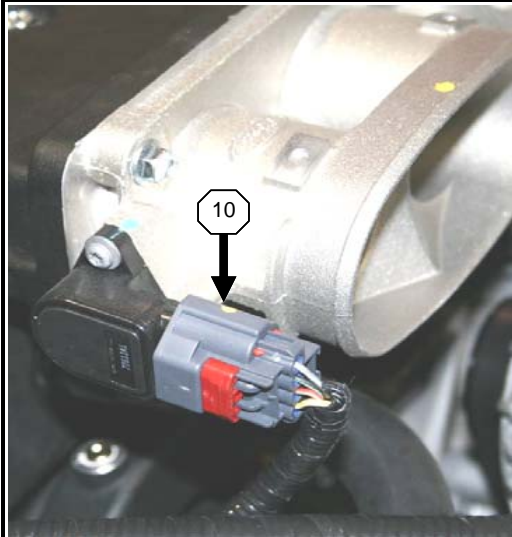

1 OF 8 FUEL INJECTORS SHOWN

- 10 Plug in the throttle control electrical connector into the passenger (RH) side of the throttle body. Press the plug onto the throttle body connector until it is fully seated, and then slide the red locking tab towards the throttle body to lock the connector into place.
- 20 Connect the throttle position connector to the driver (LH) side of the throttle body. Press the plug onto the throttle body connector until it is fully seated, and then slide the red locking tab towards the throttle body to lock the connector into place.
- 30 Connect the PCV tube to the driver (LH) side of the supercharger assembly lid. The fitting is just rearward of the throttle body. Press the tube onto the fitting until it clicks into place.
- 40 Connect the EVAP canister vapor tube into the driver (LH) side of the supercharger assembly lid. The fitting is located rearward of the PCV tube. Press the tube onto the fitting until it clicks into place.
- 50 Connect the fuel rail electrical connector to the fuel rail module located on the driver (LH) side. Press the connector into the module until the connector is fully seated.
- 60 Connect the main engine harness to each of the 8 fuel injectors. Press each grey connector onto the fuel injector until it clicks into place.
- 70 Press the fuel line onto the fuel rail fitting located on the driver (LH) side. Press the locking clip over the connection to lock the fuel line into place.

ITEM	PART NUMBER	QTY.	DESCRIPTION

NOTES:

TORQUE



PROCESS PAGE

MAKE SUPERCHARGER ASSEMBLY CONNECTIONS

TORQUE

ITEM

OPERATION

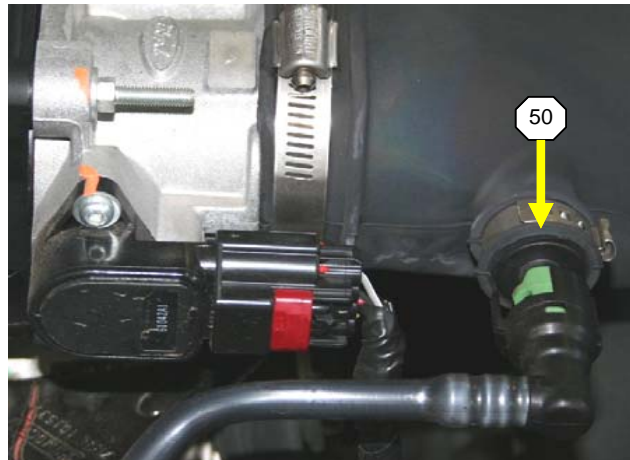
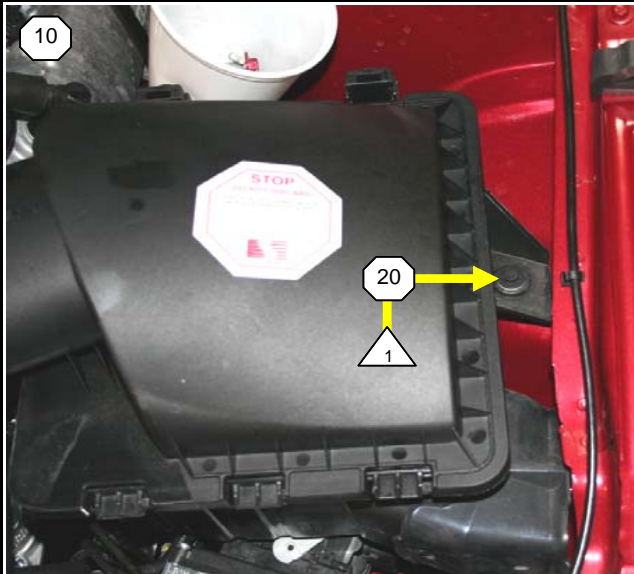

- 10 Set the modified air box assembly into the inner fender by lining up the two studs w/ grommets with the two holes in the inner fender.
- 20 Line up the air box assembly mounting hole with the J-clip on the inner fender well and re-install the 10mm air box bolt. With a torque wrench, tighten the bolt to **71 Lb-in +/- 10.6 Lb-in.**
- 30 Slip the air inlet duct (A) over the lip of the throttle body. Tighten the 8mm clamp attached to the inlet tube to **27 Lb-in +/- 4 Lb-in** with a torque wrench.
- 40 Slip the other end of the air inlet duct (B) over the lip of the air box assembly. With a torque wrench, tighten the attached 8mm clamp to **27 Lb-in +/- 4 Lb-in.**
- 50 Reconnect the crankcase vent tube to the passenger side of the air inlet duct, just in front of the throttle body. Press the tube onto the vent fitting until it locks into place.

ITEM	PART NUMBER	QTY.	DESCRIPTION
A	06-1602-C13094	1	Air Inlet Duct

NOTES:

TORQUE

1 71 +/- 10.6 Lb-in

2 27 +/- 4 Lb-in



PROCESS PAGE

INSTALL AIR BOX AND SNORKEL

TORQUE

ITEM

OPERATION

LH SIDE SHOWN - RH TYPICAL

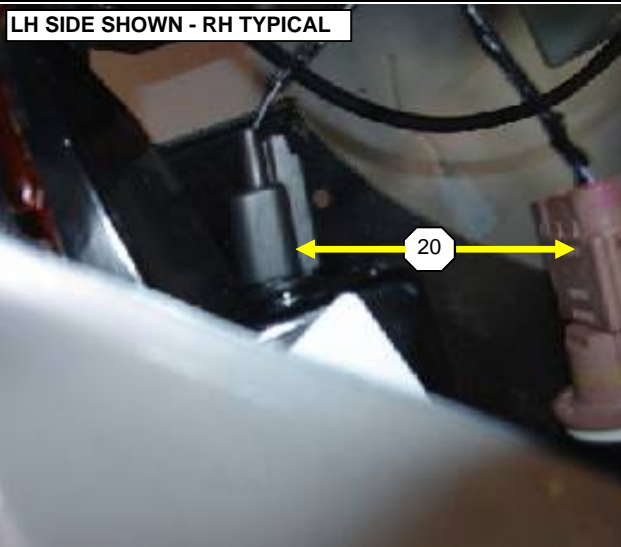

RH SIDE SHOWN - LH TYPICAL



50 RH SIDE SHOWN - LH TYPICAL



- 10 Retrieve the stock factory fascia removed on **Page 5E to7E**. Loosely set the front fascia onto the front bumper so that the electrical connections can be reached.
- 20 Connect the turn signal connectors (1 per side) and the parking light connector (1 per side). When connecting the connectors, make sure they are fully engaged.
- 30 Connect both fog light connectors (If equipped), by pressing the connector onto the fog light housing. Make sure the connector is fully seated.
- 40 Set the front fascia into place making sure the large flat tabs (1 on each side of the fascia) feed into the slot located at the bottom of each head lamp.
- 50 Once the front of the fascia is set, proceed to each side of the fascia and maneuver each side of the fascia into place. There are 2 studs protruding from the bottom of each fascia, these will feed into 2 holes on each side of the fascia.

NOTE: To confirm the connectors are properly engaged, push each connector in, give it a slight pull to make sure the connector doesn't slip out, and then push the connector back in.

ITEM	PART NUMBER	QTY.	DESCRIPTION

NOTES:

TORQUE



PROCESS PAGE

INSTALL FRONT FASCIA

STOCK MUSTANG GT

E

76

TORQUE

ITEM

OPERATION

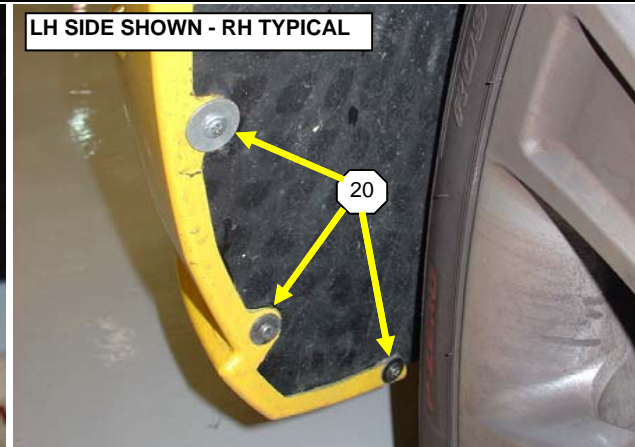

LH SIDE SHOWN - RH TYPICAL

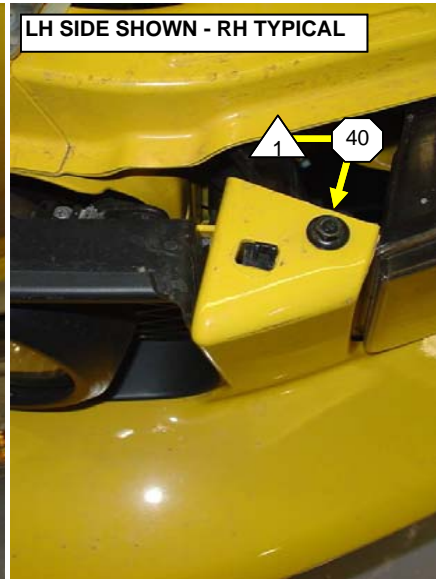
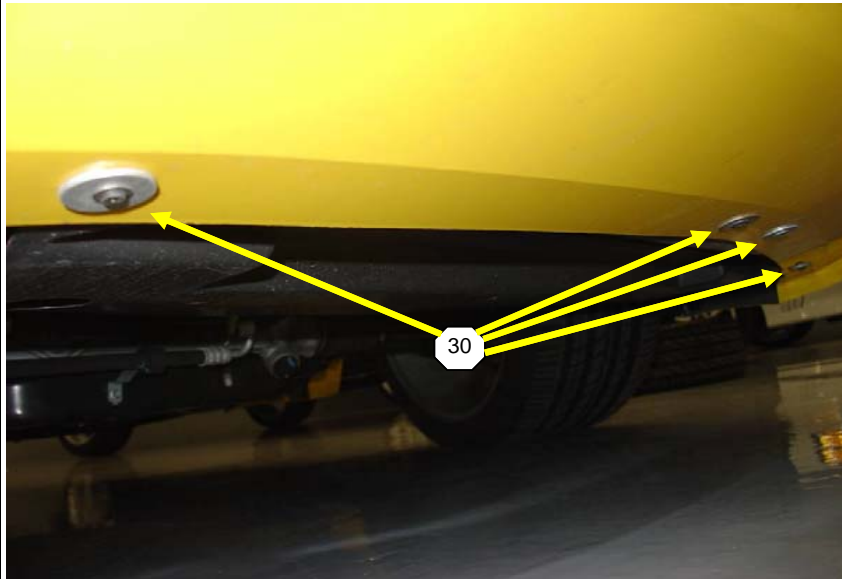

LH SIDE SHOWN - RH TYPICAL

- 10 Once the edges of the fascia are in place, pull the fender liner out enough to see the 2 fender studs per side. Re-install the 10mm nuts (2 per side). With a torque wrench, torque all 4 fender nuts to **44 Lb-in +/- 6.6 Lb-in.**
- 20 Tuck the each wheel well liner into the fascia. Re-install the 3 Philips screws per side, and tighten.
- 30 Re- install the four 5.5mm screws used to secure the bottom of the front fascia to the lower aero shield, and tighten.
- 40 Re-install the two 10mm bolts (1 per side) holding the top of the fascia to the upper supports (located just inboard of each head lamp), and tighten to **44 Lb-in +/- 6.6 Lb-in.**

ITEM	PART NUMBER	QTY.	DESCRIPTION

NOTES:

TORQUE

1 44 +/- 6.6 Lb-in



PROCESS	PAGE
INSTALL FRONT FASCIA	E
STOCK MUSTANG GT	77



TORQUE



ITEM



OPERATION

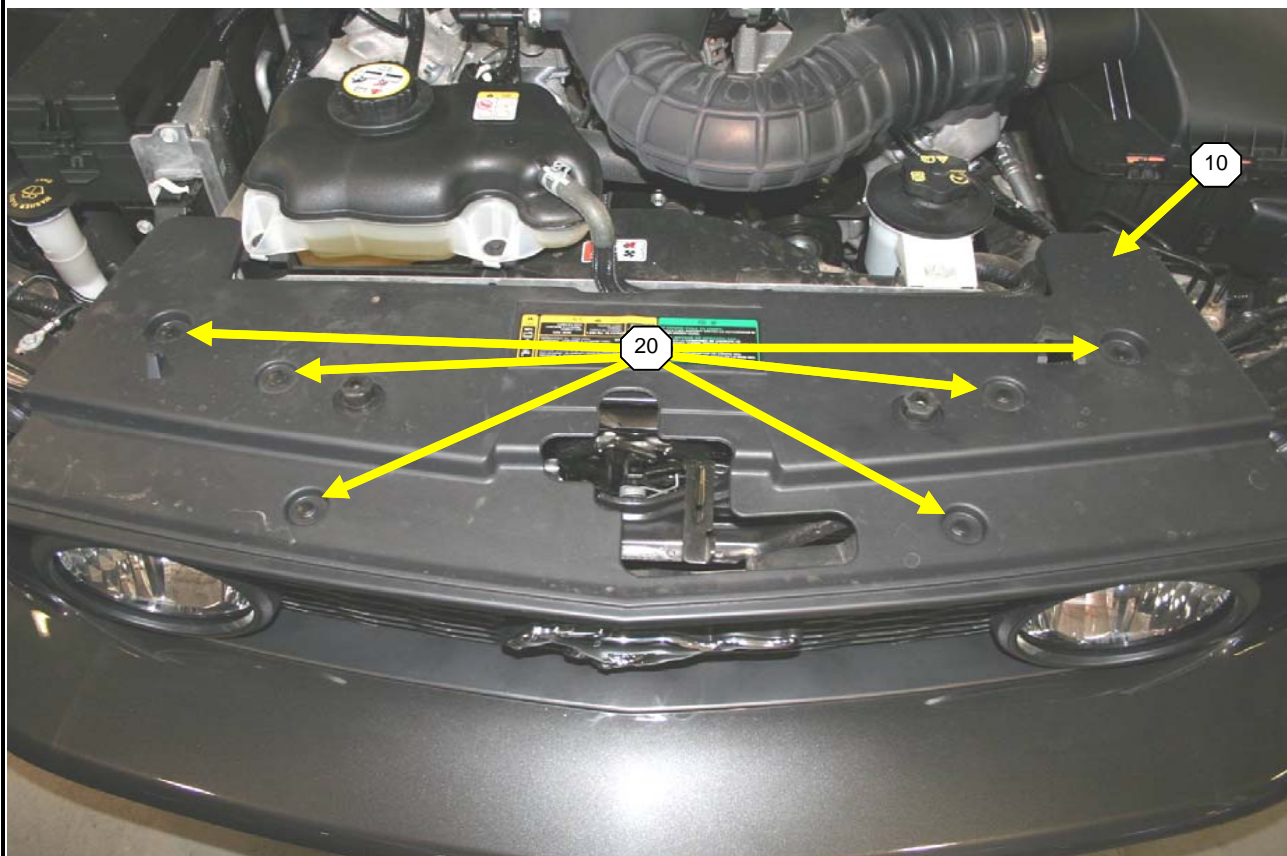

10

Feed the leading edge of the upper aero shield inside the channel molded into the top of the front grille.

20

Once in place, re-install the 6 retainer pins to secure the shield in place.

ITEM	PART NUMBER	QTY.	DESCRIPTION

NOTES:

TORQUE



PROCESS PAGE

INSTALL FRONT FASCIA

STOCK MUSTANG GT

TORQUE

ITEM

OPERATION

LH SIDE SHOWN - RH TYPICAL

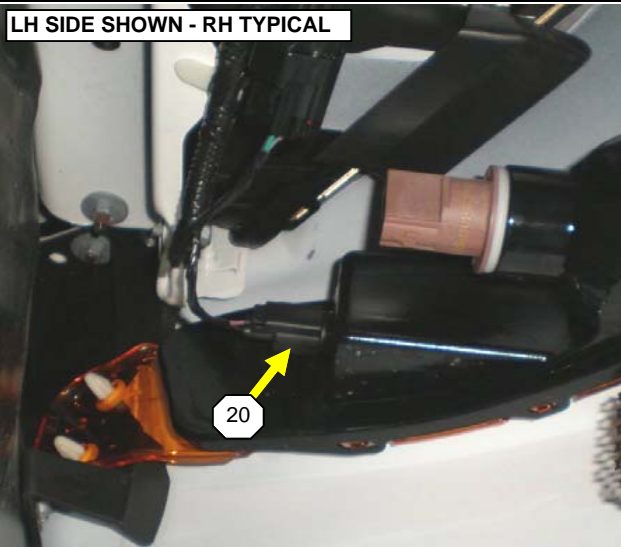

RH SIDE SHOWN - LH TYPICAL

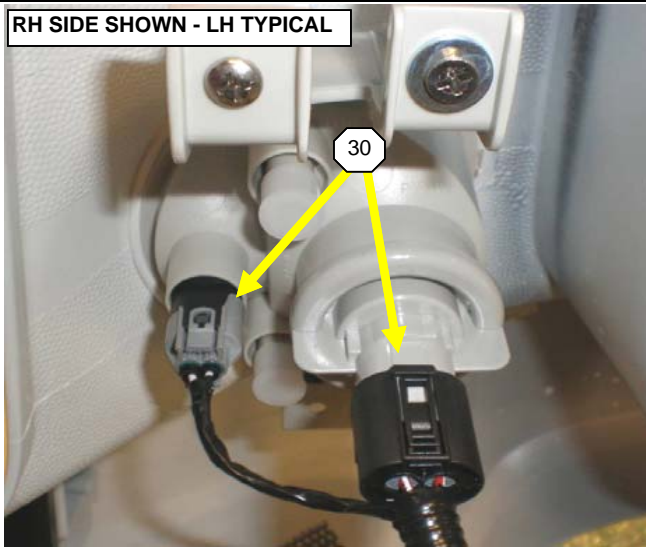

RH SIDE SHOWN - LH TYPICAL

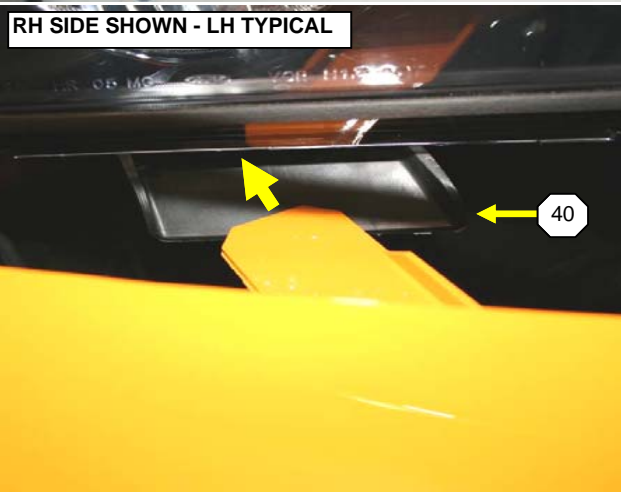

50 RH SIDE SHOWN - LH TYPICAL

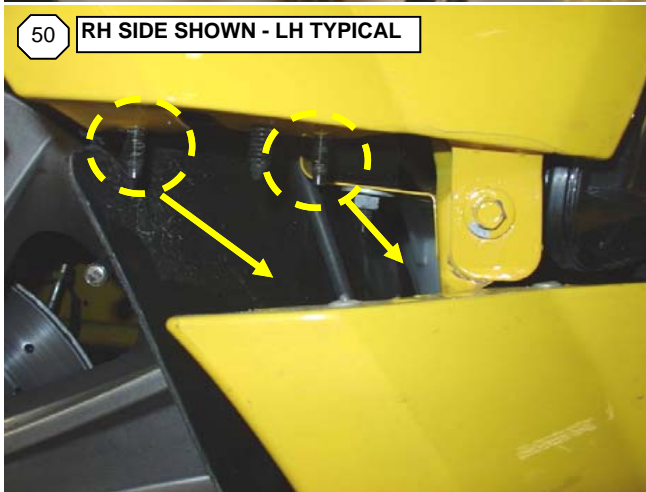

- 10 Retrieve the Saleen S-Line fascia removed on **Page 5F to 7F**. Loosely set the front fascia onto the front bumper so that the electrical connections can be reached.
- 20 Connect the side marker light connector (1 per side). When connecting the connectors, make sure they are fully engaged.
- 30 Connect the turn signal harness connectors, by pressing each connector into the turn signal housing . Make sure the connector is fully seated.
- 40 Set the front fascia into place making sure the large flat tabs (1 on each side of the fascia) feed into the slot located at the bottom of each head lamp.
- 50 Once the front of the fascia is set, proceed to each side of the fascia and maneuver each side of the fascia into place. There are 2 studs protruding from the bottom of each fascia, these will feed into 2 holes on each side of the fascia.

NOTE: To confirm the connectors are properly engaged, push each connector in, give it a slight pull to make sure the connector doesn't slip out, and then push the connector back in.

ITEM	PART NUMBER	QTY.	DESCRIPTION

NOTES:

TORQUE



PROCESS PAGE

INSTALL FRONT FASCIA

S-SERIES SALEEN FASCIA



TORQUE



ITEM



OPERATION



LH SIDE SHOWN - RH TYPICAL

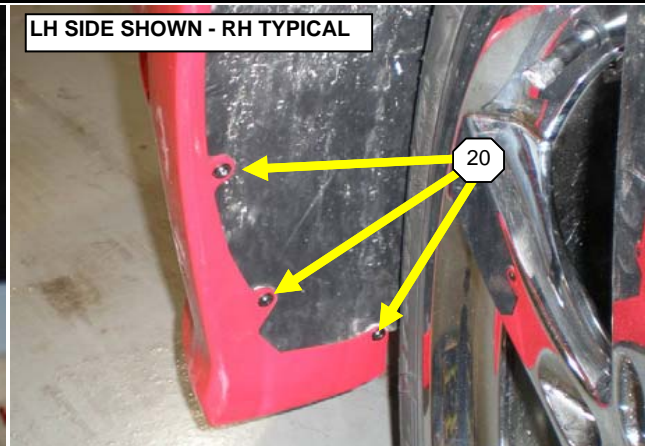

RH SIDE SHOWN - LH TYPICAL

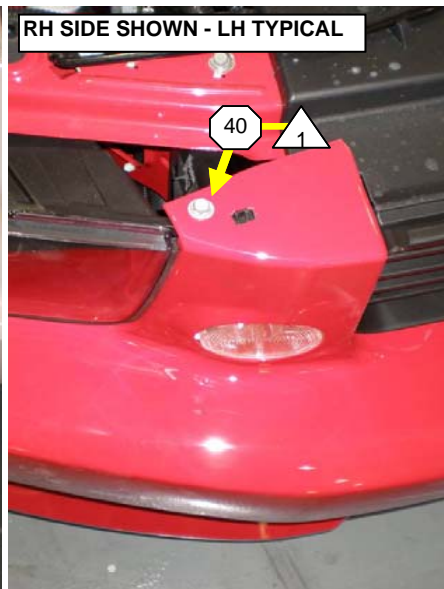

10

Once the edges of the fascia are in place, pull the fender liner out enough to see the 2 fender studs per side. Re-install the 10mm nuts (2 per side). With a torque wrench, torque all 4 fender nuts to **44 Lb-in +/- 6.6 Lb-in.**

20

Tuck the each wheel well liner into the fascia. Re-install the 3 Philips screws per side, and tighten.

30

Re- install the two 5.5mm screws used to secure the bottom of the front fascia to the lower aero shield, and tighten.

40

Re-install the two 10mm bolts (1 per side) holding the top of the fascia to the upper supports (located just inboard of each head lamp), and tighten to **44 Lb-in +/- 6.6 Lb-in.**

ITEM	PART NUMBER	QTY.	DESCRIPTION

NOTES:

TORQUE

1

44 +/- 6.6 Lb-in



PROCESS PAGE

INSTALL FRONT FASCIA

S-SERIES SALEEN FASCIA

F 77



TORQUE



ITEM



OPERATION

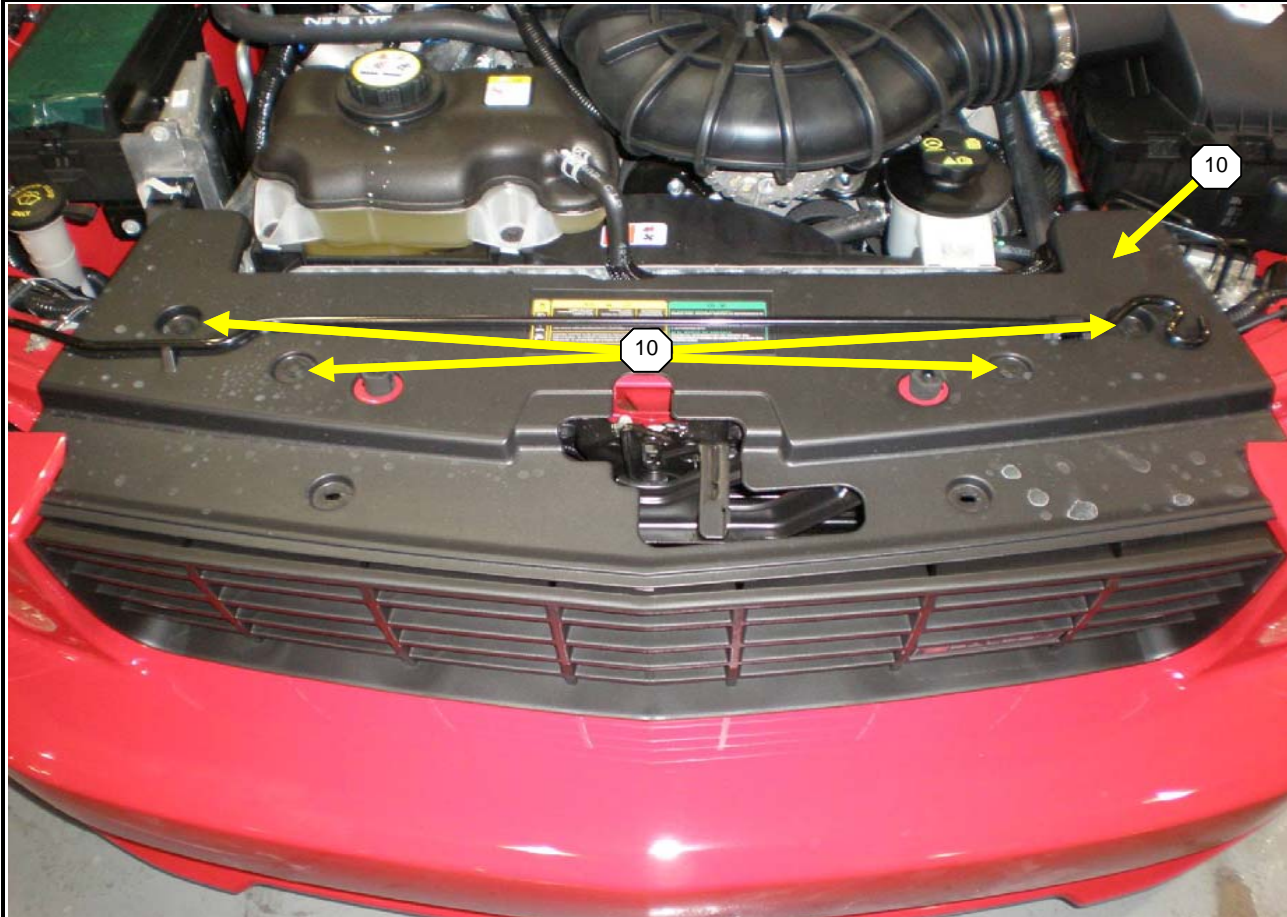

10

Set the upper aero shield into place on top of the cooling pack.

20

Once in place, re-install the 4 retainer pins to secure the shield in place.

ITEM	PART NUMBER	QTY.	DESCRIPTION

NOTES:

TORQUE



PROCESS

PAGE

INSTALL FRONT FASCIA

S-SERIES SALEEN FASCIA

F

78

TORQUE

ITEM

OPERATION

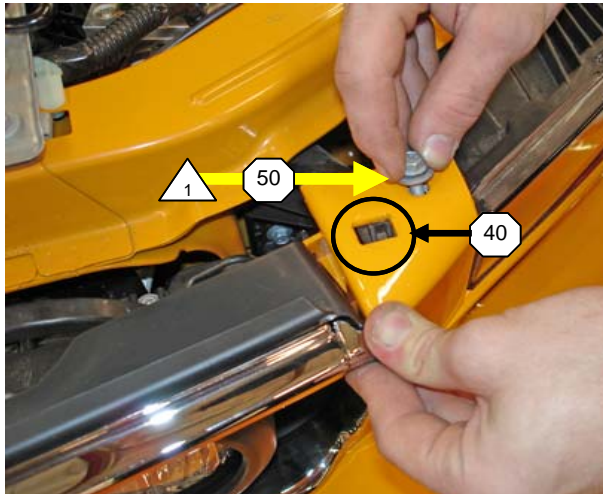
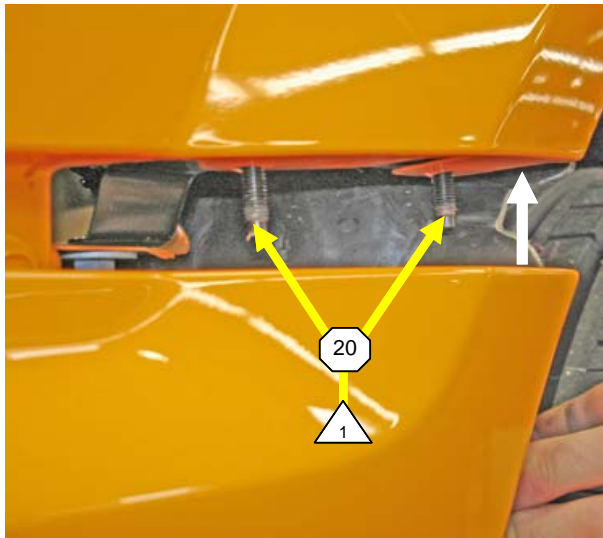
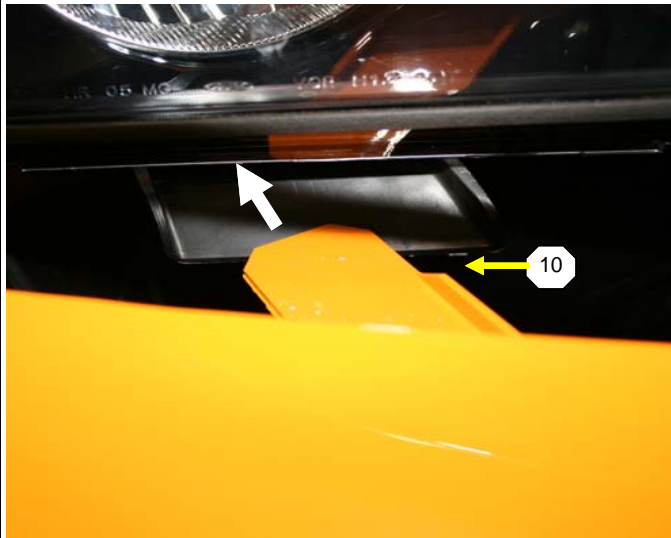

- 10 Set the front fascia into place making sure the large flat tabs (1 on each side of the fascia) feed into the slot located at the bottom of each head lamp.
- 20 Align/install the holes in the upper rear side of the fascia with the studs in the fender on each side. Install the four 10mm nuts (2 per fender, 1 per stud) onto the studs at each side of the fascia. With a torque wrench, tighten each nut to **44 Lb-in +/- 6.6 Lb-in.**
- 30 Adjust the front fascia so it fits snug against the foam that runs along the inboard vertical and lower surface of the head light.
- 40 Make sure the tab in the upper fascia support brackets sit inside the rectangular hole at the top of the fascia.
- 50 Install the two 10mm bolts (1 per side) that hold the top of the fascia to the upper support brackets, and tighten to **44 Lb-in +/- 6.6 Lb-in.**

ITEM	PART NUMBER	QTY.	DESCRIPTION

NOTES:

TORQUE



PROCESS PAGE

INSTALL FRONT FASCIA

H-SERIES SALEEN FASCIA

G

77

▲ TORQUE

□ ITEM

○ OPERATION

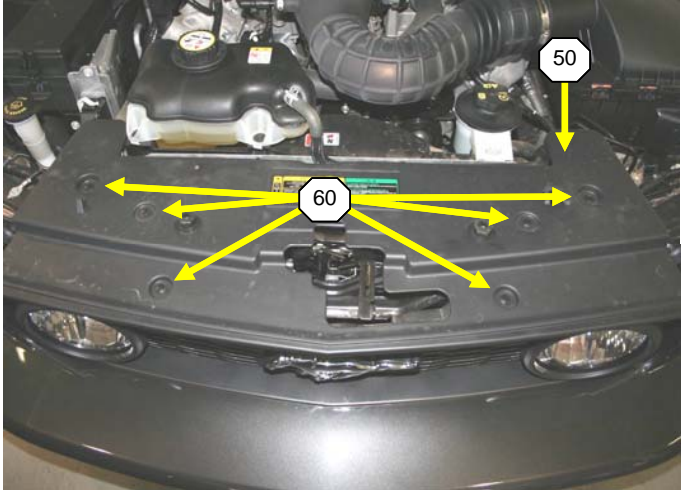
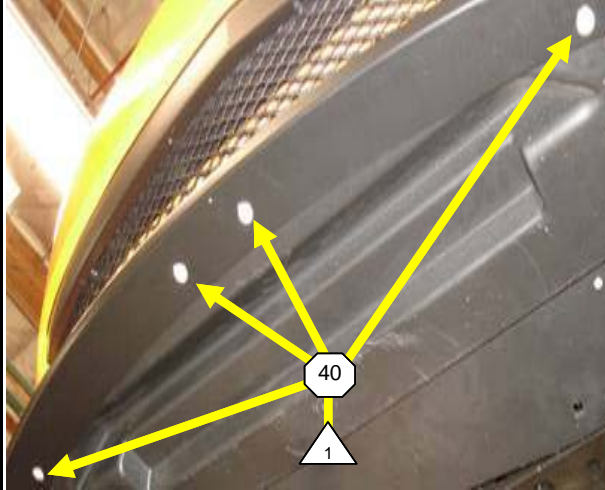
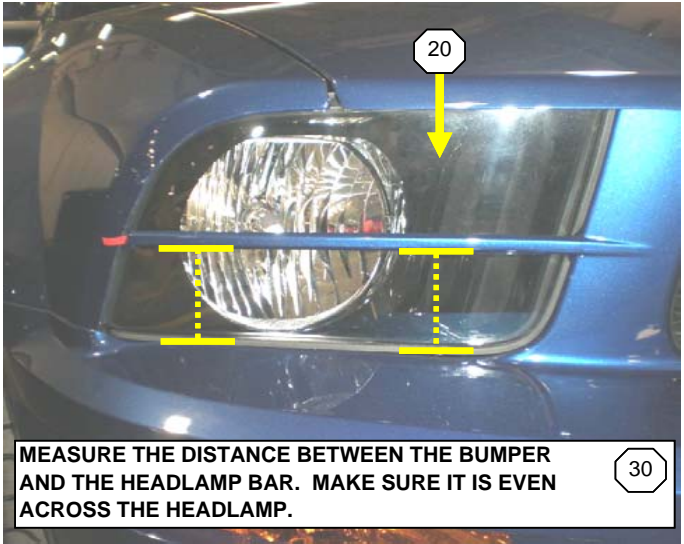

- 10 Install and tighten the 6 screws (3 per wheel well) through the front fascia and wheel well liner.
- 20 Clean each headlamp lens of dirt, dust, or any other debris before continuing to **OPERATION 30**.
- 30 Position each headlamp bar on the face of the headlamp so that it is even all the way across. To do this, measure each headlamp bar at 2 different points to make sure the bar stays level. Once the bar is in place, remove the protective backing on the tape and firmly press each bar to each headlamp.
- 40 Re-fasten the front fascia splitter to the lower aero shield with the four 5.5mm screws. The screws thread into j-clips in the aero shield. Once the screws are installed, tighten each screw to **44 Lb-in +/- 6.6 Lb-in** with a torque wrench.
- 50 Feed the leading edge of the upper aero shield inside the channel molded into the top of the front grille.
- 60 Once in place, re-install the 6 retainer pins to secure the shield in place.

ITEM	PART NUMBER	QTY.	DESCRIPTION

NOTES:

TORQUE			PROCESS	PAGE
▲ 1	44 +/- 6.6 Lb-in			
		H-SERIES SALEEN FASCIA		78

TORQUE

ITEM

OPERATION

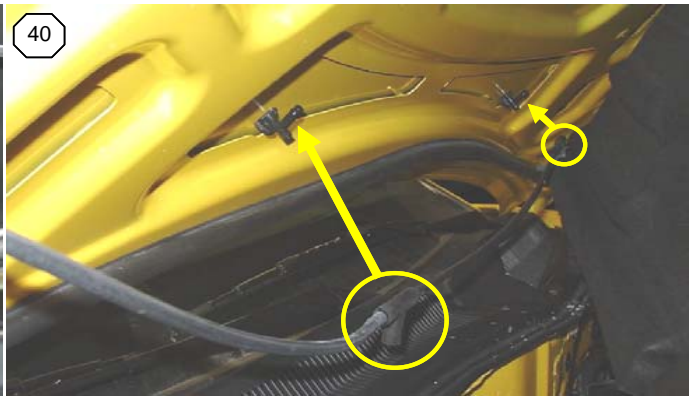
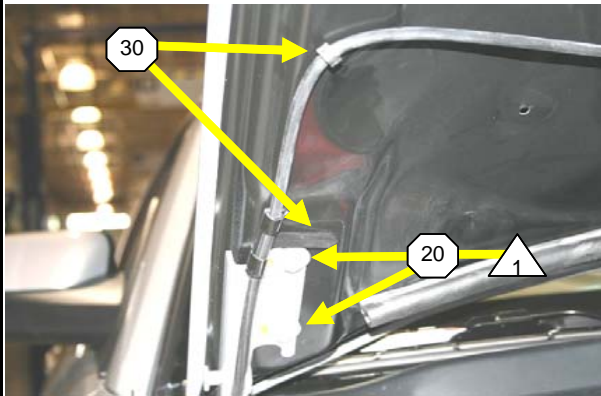
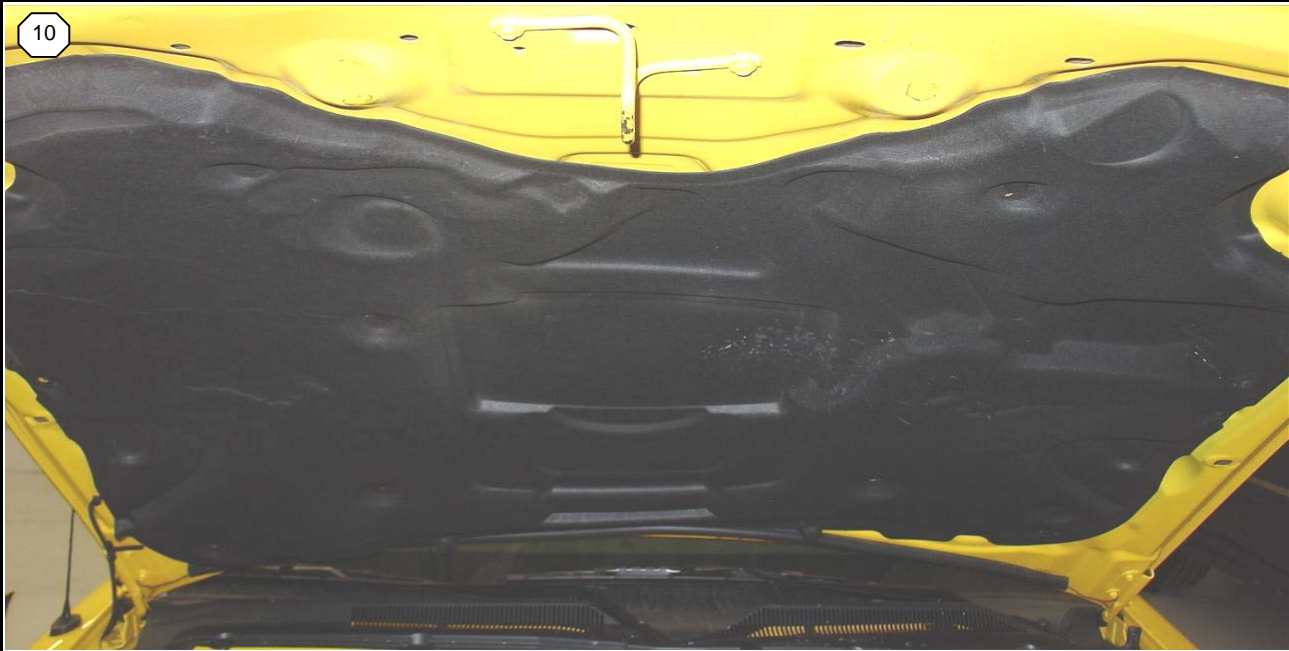

NOTICE: When installing the hood, use at least 1 additional person to help hold the hood in place. Trying to hold the hood and start the hinge bolts without help might result in injury or damage to the hood and vehicle.

10 Lift each hood hinge upward. Position the hood so that the angle of the hood matches the hinges. Bring the hood in contact with each hinge and line up the holes. Hand start the four 10mm hinge bolts. Once the bolts have been started (at least 4 threads per bolt), the hood can then be held up by the prop rod.

20 Tighten the four 10mm hinge bolts (2 per hinge) to **14 Lb-ft +/- 2 Lb-ft** with a torque wrench.

30 Take the windshield sprayer line and press the 2 line clips back into the holes in the hood.

40 Press the windshield sprayer line T-fitting and elbow back into the sprayer nozzles.

NOTICE: If the hood liner was partially or completely removed, position the liner and re-install the liner tree clips.

ITEM	PART NUMBER	QTY.	DESCRIPTION

NOTES:

TORQUE

1 14 +/- 2 Lb-ft



PROCESS PAGE

INSTALL HOOD

TORQUE

ITEM

OPERATION

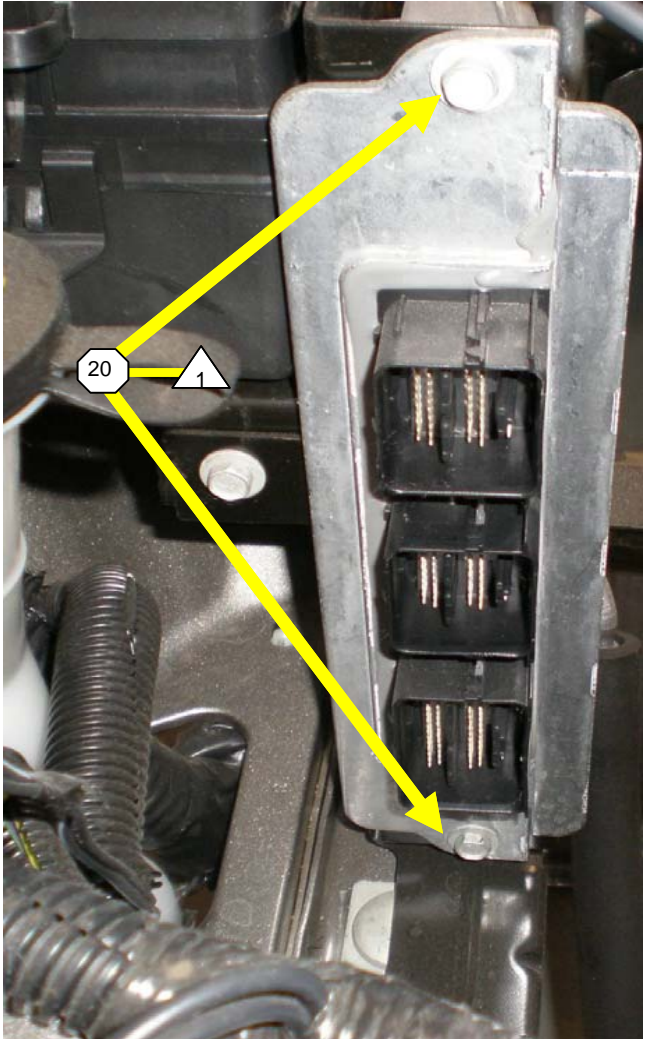
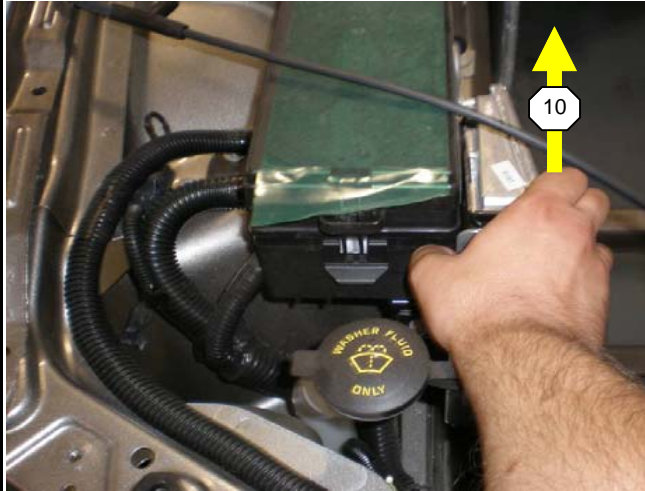

- 10 Retrieve the Saleen programmed PCM. Slide the PCM back into the PCM bracket (pushing it rearward).
- 20 Install the two 10mm bolts holding the module in place. Tighten the bolts with a torque wrench to **62 Lb-in +/- 9.3 Lb-in**
- 30 Plug the three harness connectors into their respective locations by pushing them into the connector and pushing the locking tab towards the PCM. This will lock them into place.



WARNING! Install a Saleen programmed PCM **ONLY!**

ITEM	PART NUMBER	QTY.	DESCRIPTION

NOTES:

TORQUE		SALEEN SPEEDOLAB	
1	62 +/- 9.3 Lb-in	PROCESS	PAGE
		INSTALL SALEEN PROGRAMMED PCM	80

TORQUE

ITEM

OPERATION

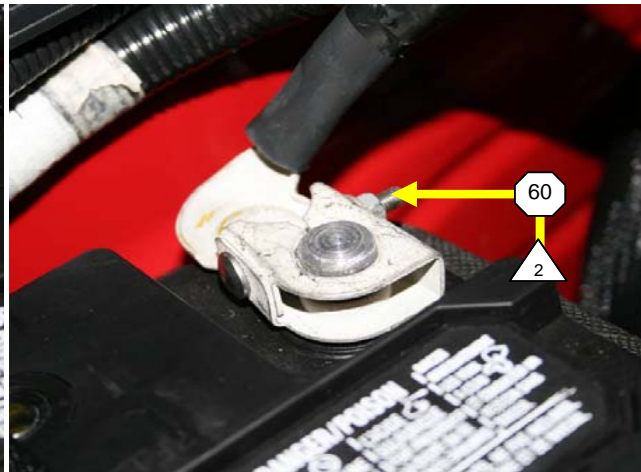
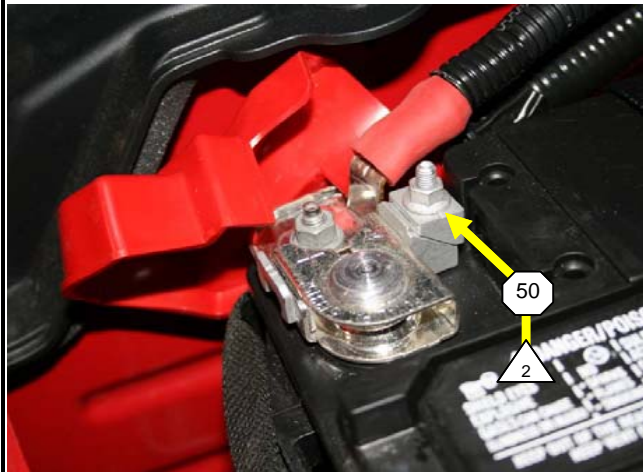
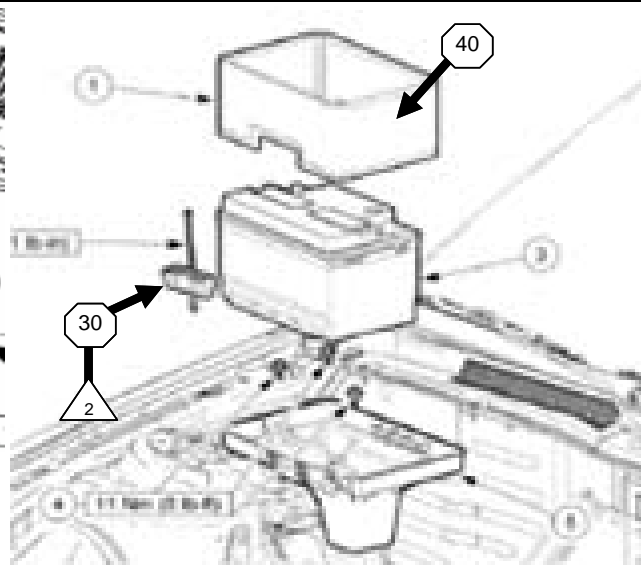
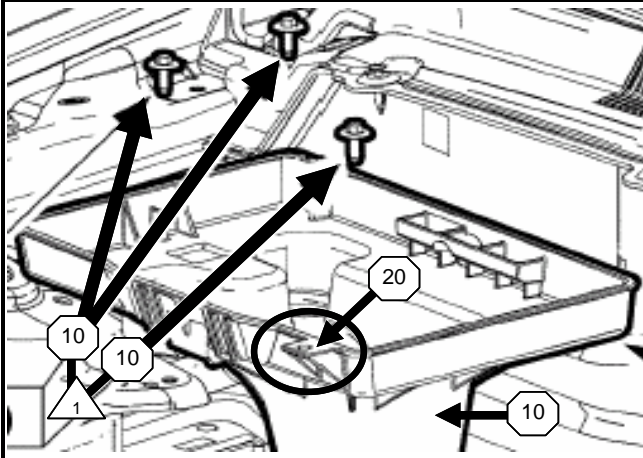

NOTICE: No smoking, flames, or sparks around the battery. Batteries can give off fumes that are flammable and may ignite if there is any form of spark or open flame near it.



Insert the battery tray into the passenger (RH) inner fender. Install the three 10mm bolts to retain it in place. Tighten the bolts to **8 Lb-ft +/- 1.2 Lb-ft** with a torque wrench.



Connect the tree clip from the battery cable harness to the battery tray.



Lower the battery into the battery tray with the posts towards the engine compartment bulkhead. Then fasten the battery hold-down to the tray (make sure the strap goes over the battery). Tighten the hold down to **71 Lb-in +/- 10.6 Lb-in** with a torque wrench.



Set the battery heat shield down around the battery with the label facing the bulkhead.



Connect the positive battery cable to the positive battery post (The post nearest the passenger (RH) fender). Using an 8mm socket, tighten the clamp to **71 Lb-in +/- 10.6 Lb-in** with a torque wrench.



Connect the negative battery cable to the negative battery post (the remaining post). Using an 8mm socket, tighten the clamp to **71 Lb-in +/- 10.6 Lb-in** with a torque wrench.

ITEM	PART NUMBER	QTY.	DESCRIPTION

NOTES:

TORQUE



8 +/- 1.2 Lb-ft



71 +/- 10.6 Lb-in



PROCESS

INSTALL BATTERY AND TRAY

PAGE

TORQUE

ITEM

OPERATION

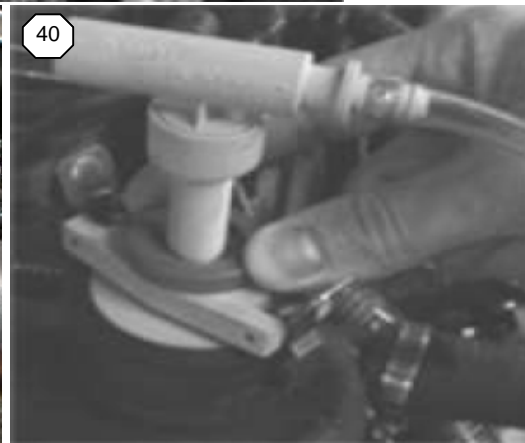
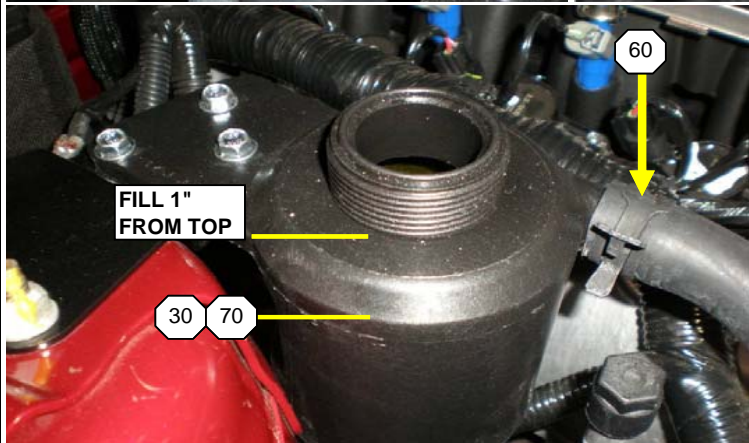
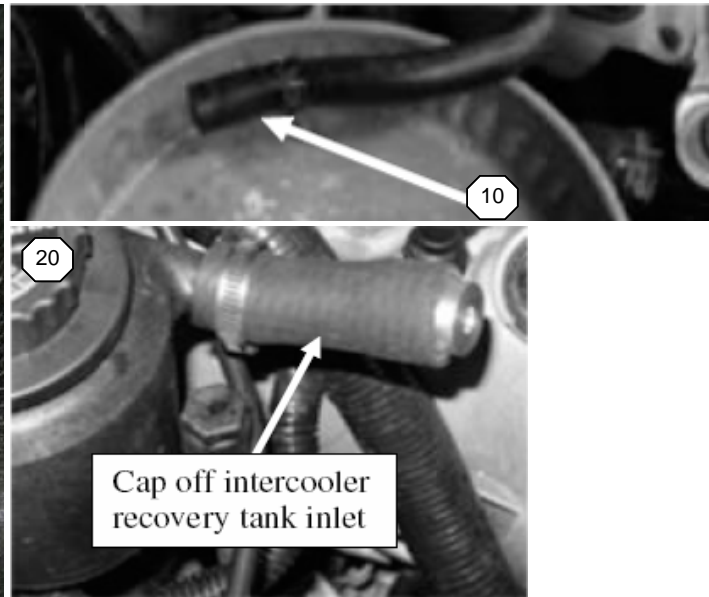
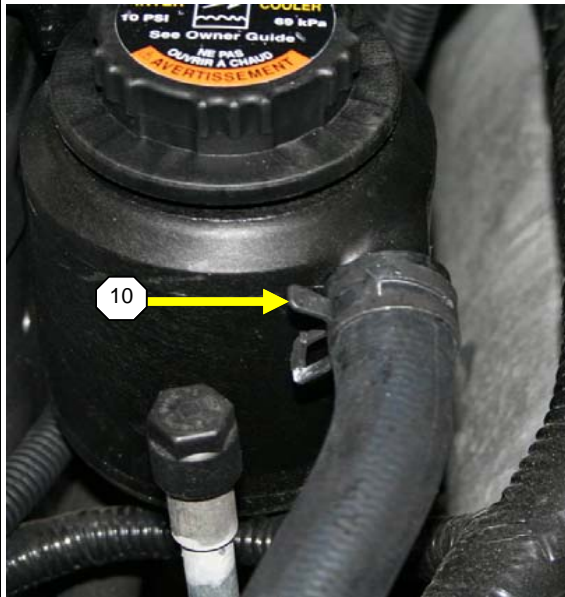

NOTICE: Fill the intercooler system with a 50/50 coolant mix (50% straight anti-freeze and 50% water).

- 10 Remove the intercooler to recovery tank hose at the intercooler and set into a drain pan.
- 20 Cap off the inlet to the intercooler recovery tank using a short piece of 3/4" hose that is plugged at one end.
- 30 Fill the reservoir tank with coolant until it is 1" from the top of the bottle.
NOTICE: See top of operations column before adding coolant.
- 40 Attach the coolant system pressure tool to the opening of the intercooler recovery tank.
- 50 Actuate the pressure tool until coolant flows out of the hose and into the drain pan. **MAKE SURE THE TANK DOES NOT RUN DRY.**
- 60 Remove the capped hose from the inlet, and re-attach the hose re-installing the designated clamp.
- 70 Remove the pressure tool and fill the intercooler tank 1" from the top. Then re-install the intercooler recovery tank cap.

ITEM	PART NUMBER	QTY.	DESCRIPTION

NOTES:

TORQUE



PROCESS

FILL INTERCOOLER SYSTEM WITH COOLANT

PAGE

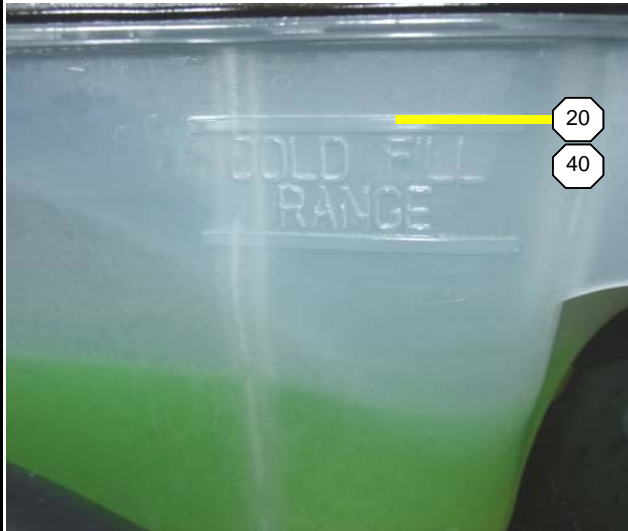
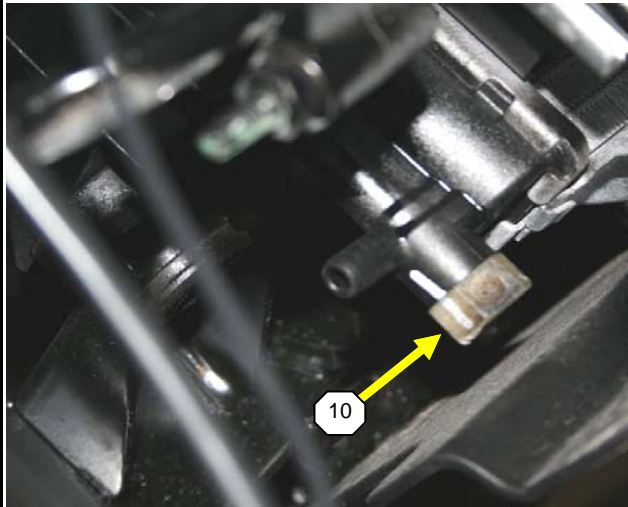

- 10 Make sure that the petcock valve at the bottom of the radiator is closed.
NOTICE: A coolant fill / recovery machine can be used to fill the coolant system and bleed out any air that might be trapped in the vehicle coolant system. If one is not available, the steps below can be used to fill the vehicle coolant system.
- 20 Refill the coolant system by pouring a 50/50 water/anti-freeze mix into the radiator recovery tank. Continue to fill the tank until the coolant level holds steady at the top of the cold fill range.
- 30 Once the tank is full, attach a radiator pressure test tool to the top of the radiator recovery tank, and apply pressure. This will help force any remaining air in the system back to the recovery tank. While performing this step, the coolant level in the tank may drop. Be sure not to let the recovery tank run dry (add additional coolant as needed).
- 40 Fill the recovery coolant level to the top of the "Cold Fill Range"
- 50 Close the recovery tank cap.
NOTICE: The steps below may need to be repeated multiple times...
- 60 Start the vehicle and let it idle until the vehicle is up to operating temperature (the thermostat is fully open).
- 70 Turn the ignition off and let the coolant system FULLY cool. The coolant level will drop in the recovery tank once the coolant fully cools.
- 80 Open the recovery tank and bring the coolant level back up to the top of the cold fill line.
NOTICE: Repeat steps 1 through 3 until the coolant level no longer drops below the fill mark after the coolant fully cools. Make sure to monitor the coolant level after every drive for the first few trips, once the air is fully worked out of the system, the level will hold steady.

WARNING! ---- PLEASE READ NOTICE BELOW

While the engine is running and right after the engine has been stopped, the coolant will be **EXTREMELY HOT!**. **DO NOT** remove the recovery tank cap and / or radiator cap while the engine is running and / or right after the vehicle has been running. Doing so will cause a sudden release of scolding hot coolant and / or steam which can cause serious burns and injuries. Always make sure the engine coolant has fully cooled before accessing any portion of the coolant system.

TORQUE



PROCESS

PAGE

FILL ENGINE COOLANT SYSTEM

TORQUE

ITEM

OPERATION

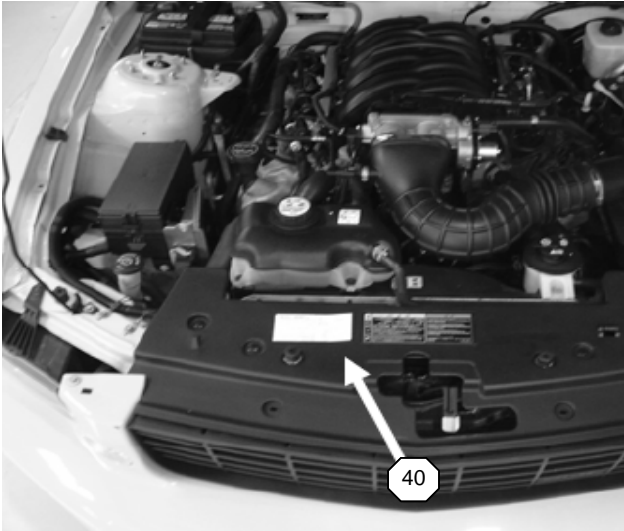
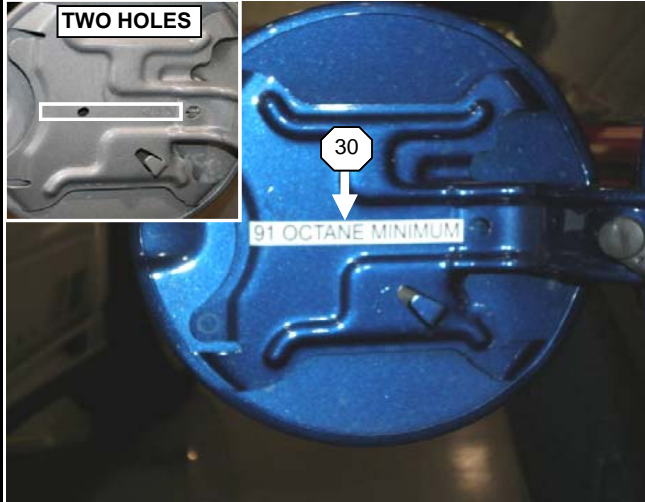

- 10 **NOTICE:** Clean all surfaces with an alcohol wipe, that a decal will be attached to ensure proper adhesion.
- 20 Open the fuel door and install the 91 octane fuel label (A) onto the back side of the fuel door as shown. Make sure the right edge of the sticker meets the right hole in the inner fuel door skin.
- 30 Open the hood and locate the oil filler neck cap (on the passenger (RH) side cam cover). Install the oil weight sticker (B) onto the oil filler neck cap making sure it is straight.
- 40 Apply the belt routing decal (C) onto the underside of the hood on the passenger (RH) side of the hood hoop. The label should be forward of the hood stop pad between the 2 holes in the inner skin.
- 50 Apply the CARB E.O. label (D) onto the radiator shroud on the passenger (RH) side of the existing Ford labels.

ITEM	PART NUMBER	QTY.	DESCRIPTION
A	06-9101-C17679	1	Label, 91 Octane Fuel Only
B	06-9101-C17108	1	Label, Oil Filler Cap 5w-30
C	06-9101-C11353	1	Label Belt Diagram S281 SC
D	10-9101-C11315	1	Label, CARB E.O.

NOTES:

TORQUE



PROCESS PAGE

INSTALL VEHICLE LABELS



Post-Installation Review

Listed below is important information about your supercharger kit. Please take the time to read the information provided. If you are installing this kit, and not the vehicle owner, please keep this page with the vehicle for the vehicle owner to review.

Post-Installation Review:

- Make sure that all electrical connections have been made
- Check the vehicle for any coolant or fuel leaks
- Verify that the intercooler water pump is running when the engine is running.
- Verify that all hazard lights (turn signals, parking lights, fog lights, etc...) are working properly.

Engine Maintenance & Care:

- Use **91 Octane fuel** or higher when re-fueling the vehicle.
- Use **5w-30** weight motor oil (of the **highest SAE rating**) in the engine instead of the stock recommended weight. As long as the engine is past the manufacturer recommended break-in, Saleen recommends synthetic motor oil.
- Change the motor oil & filter every **3,000 miles**. Oil capacity with filter change is 6 quarts.
- Change the spark plugs* every **50,000 miles**.
- Clean and re-oil the air filter every **50,000 miles**.
- Change the supercharger oil every **50,000 miles**. Saleen recommends the use of **NYE Synthetic Oil #605** for the supercharger.
- Fill the intercooler system with a **50/50 mixture** (anti-freeze / water).

*Saleen recommends the use of HTO spark plugs (**Saleen Part# 00-1601-C13394***) with this kit, if your vehicle is produced from 2005 to early model year 2008. The HTO spark plug will not fit vehicles produced after December 1st 2007. To verify if your vehicle will accept HTO spark plugs, inspect a spark plug coil. If the coil has a brown plastic sleeve, HTO plugs are not available. If the coil is all black and does not have a brown sleeve, HTO plugs can be ordered through Saleen for your vehicle.

Contact Information:

If you have any additional questions or concerns about your new Saleen supercharger kit, please feel free to contact us.

- **Tech Support:** 1-800-888-8945

Again, Saleen would like to thank you for buying a 475HP Series VI.5 Supercharger Kit. We hope you enjoy your new product, and will consider us for all your future aftermarket needs.